

CURRENT RATE [A]	VERSIONS AND PART NUMBERS		THICKNESS "S" (mm)
	A = 11 mm	A = 9 mm	
35	157.5701.5351	157.5917.5351	0.6
40	157.5701.5401	-	0.6
50	157.5701.5501	157.5917.5501	0.6
63	157.5701.5631	157.5917.5631	0.6
80	157.5701.5801	157.5917.5801	0.6
100	157.5701.6101	157.5917.6101	0.5
125	157.5701.6121	157.5917.6121	0.8
130	157.5701.6131	-	0.8
135	157.5701.6141	-	0.8
150	157.5701.6151	157.5917.6151	0.8
160	157.5701.6161	157.5917.6161	1.0
175	157.5701.6171	157.5917.6171	1.0
200	157.5701.6201	157.5917.6201	0.8
225	157.5701.6231	157.5917.6231	0.5
250	157.5701.6251	157.5917.6251	0.5
275	157.5701.6271	157.5917.6271	0.8
300	157.5701.6301	157.5917.6301	0.8
325	157.5701.6331	157.5917.6331	0.8
355	157.5701.6351	157.5917.6351	0.8
400	157.5701.6401	157.5917.6401	0.8
425	157.5701.6421	157.5917.6421	1.0
500	157.5701.6501	157.5917.6501	1.0

LTR	DATE	REVISION	DRW
A	01/FEB/23	526176GCA - INITIAL RELEASE	OPL

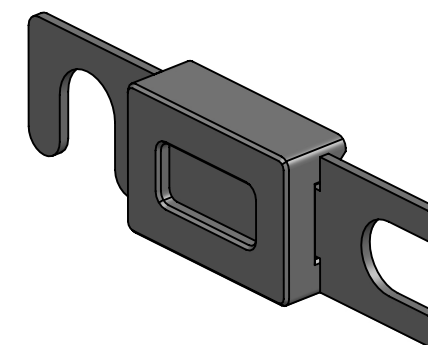

ISOMETRIC VIEW

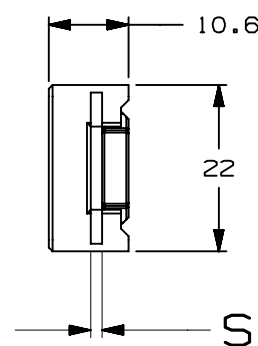
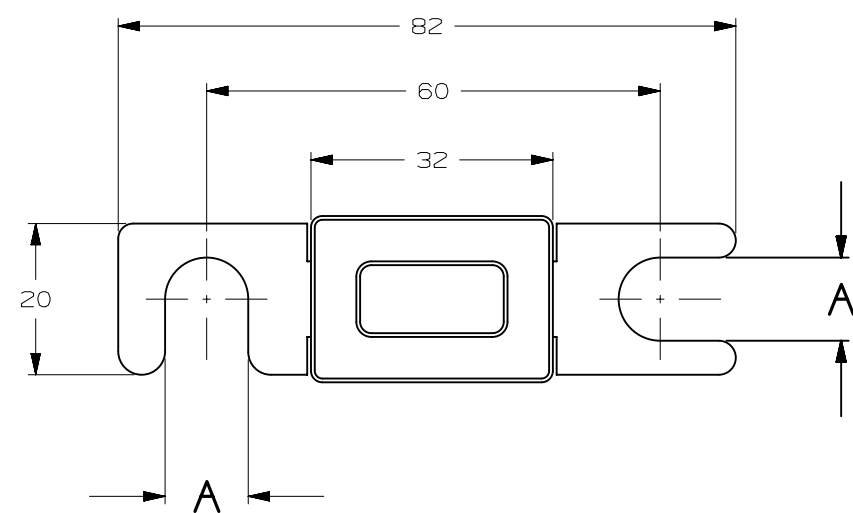

FUSE STRIPS WITH HOUSING 48V						
TERMINAL MATERIAL:	35A-80A: ZINC ALLOY 100A-500A: COPPER					
TERMINAL PLATING:	100A-500A: TIN					
HOUSING MATERIAL:	CERAMIC					
LINEAR DIMENSIONS					ANGLES	RADII
DIM	.5 - 6	6 - 30	30 - 120	120 - 400	±0.5°	±0.2
TOL	±0.1	±0.2	±0.3	±0.5		
3RD ANGLE PROJECTION		Littelfuse®		REVISION	DRWG. NO.	
		CHICAGO, USA 773-628-1000		A	WEB-157.5000.0000	