



Model RM-1000

Remote Monitor for the 777 Series

Electronic Overload Relays and Power Monitors



UG-RM-1000-B

OVERVIEW

The RM-1000/777 motor management system combines unsurpassed electronic motor protection and user-friendly motor monitoring. It improves safety by allowing personnel to program, monitor, control, and reset the device without opening the electrical cabinet.

The RM-1000 will display the following information from a 777 series product:

- Individual phase current and average current
- Current unbalance
- Individual line-to-line voltages and average voltage
- Voltage unbalance
- Ground Fault current
- Present fault trip reason and restart timer status
- Last four faults
- 777 setpoints
- Run hours on each motor
- Warning of pending (imminent) faults

The RM-1000 can monitor up to 16 777 series units over an RS-485 network using Modbus RTU protocol. A second communication port allows monitoring and control from a computer, PLC, DCS, or SCADA system.

INSTALLATION

Mounting

1. Tape or temporarily glue the mounting template on the panel in the desired location.
2. Drill four screw holes with a #23 bit (5/32").
3. Drill or punch a 2" round or 5/8" x 1 1/2" rectangular hole for the terminal connections.
4. Attach the RM-1000 to the panel using 4 #6 x 1/2" screws. Tighten the screws to no more than 10 in.-lbs.
5. Attach the wires to the terminal block and plug into the connector. (See the Wiring section.)

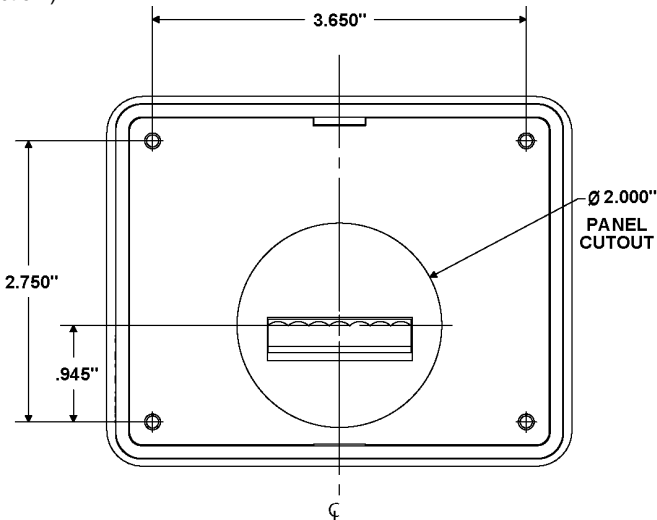

Figure 1: Mounting Diagram (Not to Scale)

Wiring

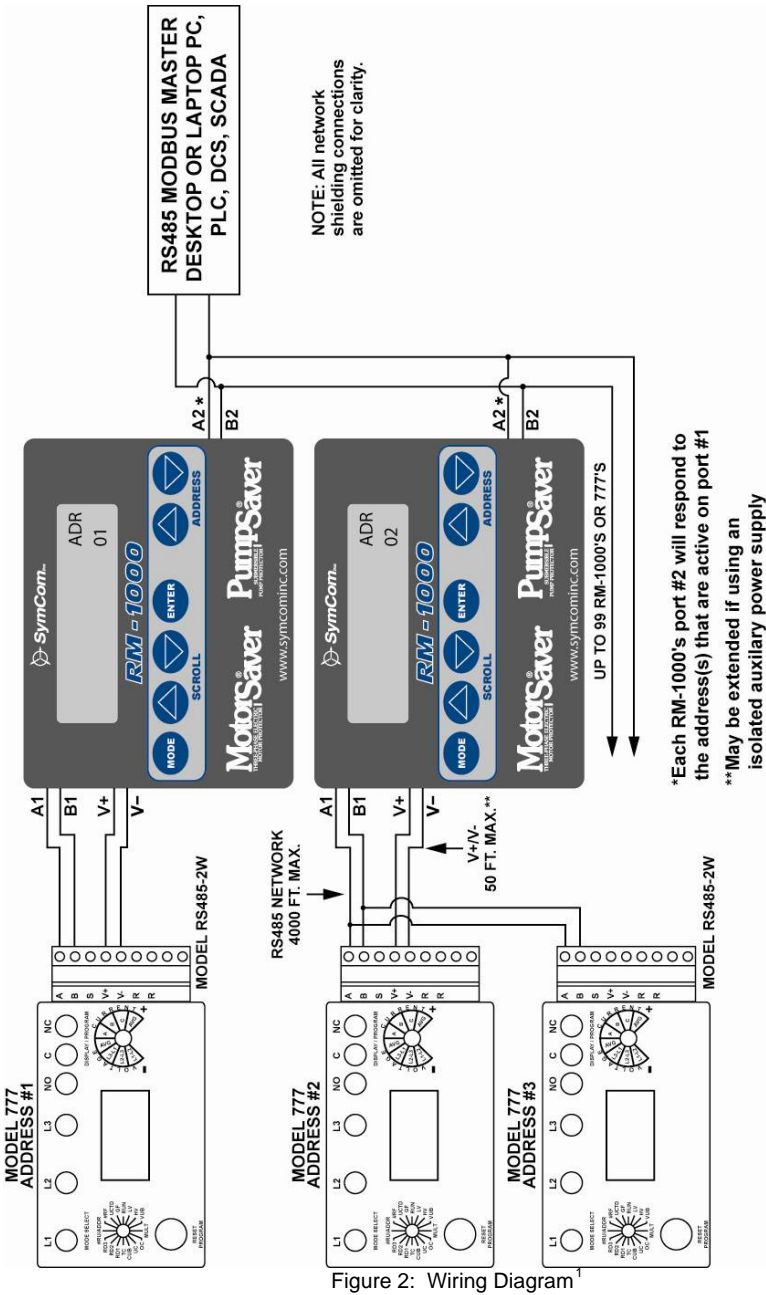

Figure 2: Wiring Diagram¹

¹ 50 ft maximum range between communication module V+/V- and remote monitor when power is provided by the communications module. Range may be extended by utilizing an isolated power supply.

QUICK START

Keypad Buttons



Figure 3: RM-1000



MODE Button – switches to the previous mode or menu. It can be thought of as a *previous, escape, or back* button.



ENTER Button – moves to the selected mode, chooses the selected option, or saves a setup parameter



SCROLL

SCROLL Up/down – moves up or down through a set of menu options or to increment or decrement a programmable setpoint.



ADDRESS

ADDRESS Up/down – moves up or down through the addresses on the network.

Keypad Programming

Menu Navigation

The programming structure is a series of menus and submenus followed by a series of programming options. The menus, submenus, and options are navigated by using a four-button interface as shown in Figure 3.

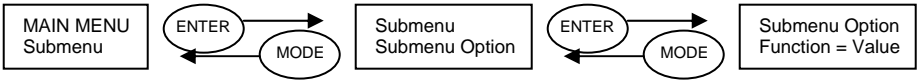

Figure 4: Menu Navigation

Changing Values

The function parameters or setpoints are changed using the SCROLL up/down buttons. When the current value of a parameter is shown an “=” sign is used. When the value is changed, the “=” changes to “?”. When the new value is saved by pressing ENTER, the “?” changes to “=.”

Enabling Network Programming

The overload relay/power monitor can have network programming disabled from a PC, PLC, or other device. If the network programming is disabled, the setpoints cannot be changed until the overload relay/power monitor has the network programming enabled. This can be done from the RM-1000. To enable network programming, go to 3_CNTRL MENU, press and hold the MODE button, then press both the SCROLL up and down buttons. The screen should display “Network Unlock Command Sent.” Network programming cannot be disabled from the RM-1000.

Quick Start Setup

Setup of a new or existing RM-1000 can be achieved very quickly by using the **Learn Nodes** and the **Delete All Nodes** features. The **Learn Nodes** feature can be used to scan all 99 addresses to find all existing addresses. The **Delete All Nodes** feature is helpful when many or all of the addresses have changed, or the installer is not sure which address(es) no longer exist. Ensure each 777 has a unique address before using the **Learn Nodes** feature.

New RM-1000 Installation

1. Apply power to all MotorSaver[®] and/or PumpSaver[®] relays to be monitored.
2. Set a different address into each MotorSaver[®] or PumpSaver[®] to be monitored by the RM-1000.
3. Enter **Learn Mode**.
 - a. Press ENTER at the **45_Learn Network** submenu.
 - b. Scroll to answer yes (451_Confirm ?Yes) and press ENTER.
 - c. Allow the RM-1000 to scan all 99 addresses. The RM-1000 will display the found nodes as they are located and will display the number of found nodes when complete.
 - d. Press ENTER to leave this screen.
4. Go to **Real Time** mode.
 - a. Press MODE to get to the **Main Menu**.
 - b. Press scroll down to get to the **1_REAL TIME** submenu selection.
 - c. Press ENTER.
5. Scroll through the addresses, by pressing the up or down address key, to verify the RM-1000 found all the installed devices.
6. If all the installed devices were found you are ready for normal operations. If some devices are missing, manually set up the addresses in question and/or check the wiring and power to the device(s) in question.

MAIN MENU OPTIONS / MODES

The main menu has four options: **1_REAL TIME, 2_SET POINTS, 3_CNTRL MENU** and **4_SETUP MENU**. A new RM-1000 will startup locked into the **MAIN MENU** at the **4_SETUP MENU**. The RM-1000 will not leave the setup menu/mode until at least one node / address is programmed (See QUICK START). After a node has been programmed, the RM-1000 will start up in the **1_REAL TIME** menu/mode. To access the other menus press the MODE button.

1_REAL TIME

Run Information

In the REAL TIME mode, the user can scroll through a list of run information. The SCROLL down button moves the operator down through the list of real time data. The SCROLL up button moves the operator up through the list (see Table 1).

Fault Information

The Fault Status screen is used to display both pending and existing faults. Faults that are in the process of timing down a trip delay will be described as “pending.” Faults that have caused the relay to trip and are in the process of timing down the restart delay are described as “tripped.” The Fault Status screen is a two-line screen. The Fault History screens, Flt1-Flt4, are one-line screens showing the last four trip faults (see Table 5).

Model 777-P2/P1	Model 777-P	Model 777	Model 777-KW/HP
Vavg= 456 Axx lavg = 10.00 I1 = 10.00 I2 = 10.00 I3 = 10.00 lub = 0% Vab = 456 Vbc = 456 Vac = 456 Vub = 0% GF = 0.00 Hours = 33 Strts = 1 PwrFr = 1 KW = 100 Freq = 60.0 ThCap= 100% ErCod= 0x9000 TrpRn= 0x0000 RD1 = 0s RD2 = 0m RD3 = 0m Flt1 [UndCur] Flt2 [OvrCur] Flt3 [Clear] Flt4 [Clear] Fault Status	Vavg= 456 Axx lavg = 10.00 I1 = 10.00 I2 = 10.00 I3 = 10.00 lub = 0% Vab = 456 Vbc = 456 Vac = 456 Vub = 0% GF = 0.00 Hours = 33 Strts = 1 PwrFr = 1 KW = 100 ThCap= 100% ErCod= 0x9000 TrpRn= 0x0000 RD1 = 0s RD2 = 0m RD3 = 0m Flt1 [UndCur] Flt2 [OvrCur] Flt3 [Clear] Flt4 [Clear] Fault Status	Vavg= 456 Axx lavg = 10.00 I1 = 10.00 I2 = 10.00 I3 = 10.00 lub = 0% Vab = 456 Vbc = 456 Vac = 456 Vub = 0% GF = 0.00 Hours = 33 PwrFr = 1 RD1 = 0s RD2 = 0m RD3 = 0m Flt1 [UndCur] Flt2 [OvrCur] Flt3 [Clear] Flt4 [Clear] Fault Status	Vavg = 456 Axx lavg = 10.00 I1 = 10.00 I2 = 10.00 I3 = 10.00 lub = 0% Vab = 456 Vbc = 456 Vac = 456 Vub = 0% GF = 0.00 Hours = 33 PwrFr = 1 KW = 100 RD1 = 0s RD2 = 0m RD3 = 0m Flt1 [Low kW] Flt2 [OvrCur] Flt3 [Clear] Flt4 [Clear] Fault Status
		Model 601	Model 77C
		Vavg = 456 Axx Vab = 456 Vbc = 456 Vac = 456 Vub = 0% Freq = 60.0 RD1 = 0s RD2 = 0m Flt1 [Hi Vlt] Flt2 [Lo Frq] Flt3 [Clear] Flt4 [Clear]	V = 456 Axx I = 10.00 Hours = 33 RD1 = 0s RD2 = 0m RD3 = 0m Flt1 [UndCur] Flt2 [OvrCur] Flt3 [Clear] Flt4 [Clear]

Table 1: REAL TIME Mode Screens

Abbr.	Description	Abbr.	Description
Vavg	Average Voltage	Strts	Starts
Iavg	Average Current	PwrFr	Power Factor
I1	Phase 1 Current	kW	Power
I2	Phase 2 Current	Freq	Frequency
I3	Phase 3 Current	ThCap	Thermal Capacity
Iub*	Current Unbalance	ErCod	Error Code
Vab	Voltage A-B	TrpRn	Trip Reason
Vbc	Voltage B-C	RD1	Rapid-Cycle Timer
Vac	Voltage A-C	RD2	Cool-Down Timer
Vub	Voltage unbalance	RD3	Dry-Well Recovery Timer
GF	Ground Fault	Flt#	Last Faults
Hours	Run Hours		

Table 2: REAL TIME Mode Abbreviations

Abbr.	Description	Abbr.	Description
OC	Overcurrent	VUB	Voltage Unbalance
ISP	Current Single Phase	HV	High Voltage
VSP	Voltage Single Phase	LV	Low Voltage
UB*	Current Unbalance	GF	Ground Fault
RP	Reverse Phase	HF	High Frequency
UC	Undercurrent	LF	Low Frequency
LPr	Low Power		

Table 3: Pending Fault Abbreviations

Abbr.	Description	Abbr.	Description
HV	High Voltage	UB*	Current Unbalance
LV	Low Voltage	OC	Overcurrent
CF	Contactors Failure	UC	Undercurrent
RP	Reverse Phase	HF	High Frequency
SP	Single Phase	LF	Low Frequency
GF	Ground Fault	LPr	Low Power
Hot	High Motor Temp.		

Table 4: Tripped Fault Abbreviations

Abbr.	Description	Abbr.	Description
Hi Vlt	High Voltage	Unbal*	Current Unbalance
Lo Vlt	Low Voltage	OvrCur	Overcurrent
Cnt FI	Contactors Failure	UndCur	Undercurrent
Rev Ph	Reverse Phase	Hi Frq	High Frequency
Sng Ph	Single Phase	Lo Frq	Low Frequency
Grnd F	Ground Fault	Low Pr	Low Power
Hot	High Motor Temp.		

Table 5: Last Fault Abbreviations

*For the Model 601, UB and Unbal refer to Voltage Unbalance

2_SET POINTS

In the SET POINTS mode, the user can scroll through a list of setpoints for each installed device. The SCROLL up/down buttons are used to move through the list. The ADDRESS up/down buttons are used to change devices. If change setpoints is enabled in the Setup menu, the user can change the setpoint by pressing ENTER. Then, the SCROLL button is used to change the value and ENTER is used to accept the value.

(Refer to the Installation Instructions and Programming Guide for the monitored device).

Model 777-P2		Model 777-P1		Model 777-P		Model 777	
2a	LV	2a	LV	2a	LV	2a	LV
2b	HV	2b	HV	2b	HV	2b	HV
2c	VUB	2c	VUB	2c	VUB	2c	VUB
2d1	CT Mult	2d1	CT Mult	2d1	CT Mult	2d	MULT
2d2	CT Divsr	2d2	CT Divsr	2d2	CT Divsr	2e	OC
2d	MULT	2d	MULT	2d	MULT	2f	UC
2e	OC	2e	OC	2e	OC	2g	IUB
2f	UC	2f	UC	2f	UC	2h	TC
2g	IUB	2g	IUB	2g	IUB	2i	RD1
2h	TC	2h	TC	2h	TC	2j	RD2
2i	RD1	2i	RD1	2i	RD1	2k	RD3
2j	RD2	2j	RD2	2j	RD2	2l	#RU
2k	RD3	2k	RD3	2k	RD3	2m	#RF
2l	#RU	2l	#RU	2l	#RU	2n	UCTD
2m	#RF	2m	#RF	2m	#RF	2o	GF
2n	UCTD	2n	UCTD	2n	UCTD		
2o	GF	2o	GF	2o	GF		
2p	LKW	2p	LKW	2p	LKW		
2aa	HKW	2aa	HKW	2aa	HKW		
2ab	Hpr TD	2ab	Hpr TD	2ab	Hpr TD		
2ac	KW scale	2ac	KW scale	2ac	KW scale		
2ad	GF TD	2ad	GF TD	2ae	CommPrm		
2ae	CommPrm	2ae	CommPrm	2af	En/Dis		
2af	En/Dis	2af	En/Dis	2ag	CfgCtrl		
2ag	CfgCtrl	2ag	CfgCtrl	2ah	Net St		
2ah	Net St	2ah	Net St	2ai	LCV Dly		
2ai	LCV Dly	2ai	LCV Dly	2aj	LCV Pct		
2aj	LCV Pct	2aj	LCV Pct	2ak	LinOC TD		
2ak	LinOC TD	2ak	LinOC TD	2al	CUB TD		
2al	CUB TD	2al	CUB TD	2am	MA Ctrl		
2am	MA Ctrl	2am	MA Ctrl	2an	MA TD		
2an	MA TD	2an	MA TD	2ao	HotOC %		
2ao	HotOC %	2ao	HotOC %				
2ap	JS1 TD	2ap	JS1 TD				
2aq	JS1 Inh	2aq	JS1 Inh				
2ar	JS1 Pct	2ar	JS1 Pct				
2as	JS2 TD	2as	JS2 TD				
2at	JS2 Inh	2at	JS2 Inh				
2au	JS2 Pct	2au	JS2 Pct				
2av	Volt En	2av	Volt En				
2aw	GF SF						
2ax	GF Inh						

Model 777-KW/HP*	
2a	LV
2b	HV
2c	VUB
2d	MULT
2e	OC
2g	IUB
2h	TC
2i	RD1
2j	RD2
2k	RD3
2l	#RU
2m	#RF
2n	UCTD
2o	GF
2p	LKW

Model 77C	
2a	LV
2b	HV
2d	MULT
2e	OC
2f	UC
2h	TC
2i	RD1
2j	RD2
2k	RD3
2l	#RU
2m	#RO
2n	UCTD

Model 601	
2a	LV
2b	HV
2c	VUB
2i	RD1
2j	RD2
2m	#RF

Table 6: Setpoint Screens

* 777-KW/HP-P2 will follow the 777-P2 screens.

Abbr.	Description	Abbr.	Description
LV	Low Voltage	GF TD	Ground Fault Trip Delay
HV	High Voltage	CommPrm	Communication Parameter Bits
VUB	Voltage Unbalance	En/Dis	Enable/Disable Bits
CT Mult	Current Transformer Multiplier	CfgCtrl	Configuration Control Bits
CT Divsr	Current Transformer Divisor	Net St	Network Status
MULT	Current Multiplier	LCV Dly	Low Control Voltage Delay
OC	Overcurrent	LCV Pct	Low Control Voltage Percentage
UC	Undercurrent	LinOC TD	Linear Over Current Trip Delay
IUB	Current Unbalance	CUB TD	Current Unbalance Trip Delay
TC	Trip Class	MA Ctrl	Motor Acceleration Control
HF	High Frequency	MA TD	Motor Acceleration Trip Delay
LF	Low Frequency	HotOC %	Hot Overcurrent Percentage
RD1	Rapid-Cycle Timer	JS1 TD	Jam/Stall 1 Trip Delay
RD2	Cool-Down Timer	JS1 Inh	Jam/Stall 1 Inhibit Delay
RD3	Dry-Well Recovery Timer	JS1 Pct	Jam/Stall 1 Percentage
#RU	Number of Restarts after UC Faults	JS2 TD	Jam/Stall 2 Trip Delay
#RF	Number of Restarts after Faults	JS2 Inh	Jam/Stall 2 Inhibit Delay
UCTD	Undercurrent Trip Delay	JS2 Pct	Jam/Stall 2 Percentage
GF	Ground Fault	Volt En	Voltage Enable Bits
LKW	Low Power	GF SF	Ground Fault Scale Factor
HKW	High Power	GF Inh	Ground Fault Inhibit Delay
Hpr TD	High Power Trip Delay		
KW scale	Kilowatt Scale Factor		

Table 7: Setpoint Screen Abbreviations

3_CNTRL MENU

The CONTROL submenus are used to reset a tripped relay, send an OFF command to a relay, clear the last fault memory and to clear the run-hour counter.

After pressing ENTER to select a control option, the RM-1000 will ask for confirmation before executing the command. Press the SCROLL up or down button to change the response to yes and press ENTER to confirm the request.

31_Set OFF

Press ENTER at this menu option to send an OFF command to a relay. After confirming the request an OFF command will be sent. The MotorSaver[®] or PumpSaver[®] will remain in the off state (relay de-energized) until the reset button is pressed, or a RESET command is sent from the RM-1000 or the host network.

32_Reset

Press ENTER at this menu option to send a RESET command. The relay will be reset after confirming the request.

33_Clear LF (Clear Last Fault)

Press ENTER at this menu option to clear the last fault memory location in the relay, provided the relay supports the clear last fault function. Placing a CLEAR in the last fault memory location can be a helpful tool in system troubleshooting, ending any uncertainty about whether the last fault is new or very old.

34_Clear Hrs (Clear Run Hours)

Press ENTER at this menu option to clear the accumulated run hours, provided the relay supports the run hour feature. The run hour counter will be cleared when the command is confirmed.

35_Clear St (Clear Starts)

Press ENTER at the menu option to clear the accumulated starts, provided the relay supports the starts feature. The starts counter will be cleared after confirming the request.

36_Read Regs (Read Registers)

Press ENTER at this menu option to read selected modbus registers. Two set register commands (Set Rg1 and Set Rg2) can be modified from 0 to 0xFFFF to allow a READ (Rd1 and Rd2) of any modbus register. This setting is in hexadecimal. Refer to the device programming guide for register functions.

4_SETUP MENU

41_Gen Options

411_Setpoint Lock

The unlock setpoint option allows enabling or disabling network programming of the setpoints of the relays on the network. If disabled, the operator can only view the setpoints of the relay, not change them.

412_A/S Rate

The Auto Scroll feature allows the RM-1000 REAL TIME mode screens to automatically scroll from one screen to the next at a desired interval. The intervals range from 0.5-127.5 seconds at 0.5-second intervals. Setting the rate to OFF disables the Auto Scroll feature.

413_A/S KeyDelay

If the Auto Scroll feature is enabled and one of the buttons on the keypad are pressed, the Auto Scroll feature is temporarily disabled for the amount of time set in the Auto Scroll Key Delay. The delay range is 0.5-127.5 seconds at 0.5 second intervals. Setting the delay to OFF disables the Auto Scroll feature.

414_Trip Notify

If the Trip Notify is enabled, the RM-1000 will display the trip screen when a device on the network trips on a fault. If the Trip Notify is disabled, the RM-1000 will not display the trip screen when a device on the network trips.

415_Reference

This menu option displays the firmware version number.

42_Edit Nodes

4212_Model

Options: 777P2, 777P1, 777-P, 777, 777-KW/HP, 77C, 601

777P2 - All Model 777-P2 relays

777P1 - All Model 777-P1 relays

777-P - All Model 777-P relays

777- All Model 777 relays except Model 777-KW/HP

777-KW/HP- All Model 777-KW/HP relays

77C- All single-phase relays, Model 77C and 777-HVR-SP

601- All Model 601 voltage monitors

This menu option is only needed for older model 601 relays. The RM-1000 is able to recognize the model of all compatible relays except older model 601s.

This setting will automatically be overridden by the RM-1000 if it is programmed incorrectly.

4213_UC Alarm

Treat undercurrent as alarm if enabled.

4214_Unit Code

Displays the unit code of the attached relay

Examples: 1=777 (standard), 2=777-HVR, 3=777-575

11=777-LR, 12=777-HVR-LR, 13=777-575-LR

31=777-MV

41=777 KW/HP, 42=777 HVR KW/HP

51=777 KW LR

43_Comm Settings

The communication settings can be set to standard or custom². Standard is the default setting.

431_Slave Comm

Selecting "Cst" (Custom) allows the individual setup of baud rate, parity and stop bits for the slave port, terminals A1 and B1.

4311_Slave Baud

Slave port baud rate - '9600' is the default.

Options: 1200, 2400, 9600, 14400, 19200, 28800

4312_Slave Prty

Slave port parity - 'Even' is the default.

Options: E (Even), O (Odd), N (None)

4313_Slave Stop

Number of Stop bits for the slave port - '1' is the default.

Options: 0, 1, 2

432_Host Comm

The communication settings can be set to standard or custom. Standard is the default setting which sets the communication parameters to 9600 baud, even parity and one stop bit (9600,E,1) for the host port, terminals A2 and B2.

4321_Host Baud

Host port baud rate - '9600' is the default.

Options: 1200, 2400, 9600, 14400, 19200, 28800

4322_Host Parity

Host port parity - 'even' is the default.

Options: E (Even), O (Odd), N (None)

4323_Host Stop

Number of Stop bits for the host port - '1' is the default.

Options: 0, 1, 2

44_Del All Nodes

This function deletes all programmed nodes from the RM-1000 memory. This feature is useful when moving an RM-1000 or making many changes to the system.

NOTE: If all nodes are deleted, the RM-1000 will remain in the 4_SETUP MENU until at least one node is programmed.

45_Learn Network

This function scans all network addresses from 1-99 in search of installed equipment. Any device that is found is programmed into the next available node. Devices already programmed into the RM-1000 will not be lost.

This function can be aborted at any time by pressing the MODE button. The found nodes will be programmed. This allows the scan to be stopped as soon as all existing nodes have been found.

If the model can be read, no further programming is necessary. Only older Model 601 voltage monitors need to have the model programmed in submenu 4212.

² The basic 777 family, Model 77C, and Model 601 only support the standard communication settings of 9600 baud, even parity and one stop bit (9600,E,1).

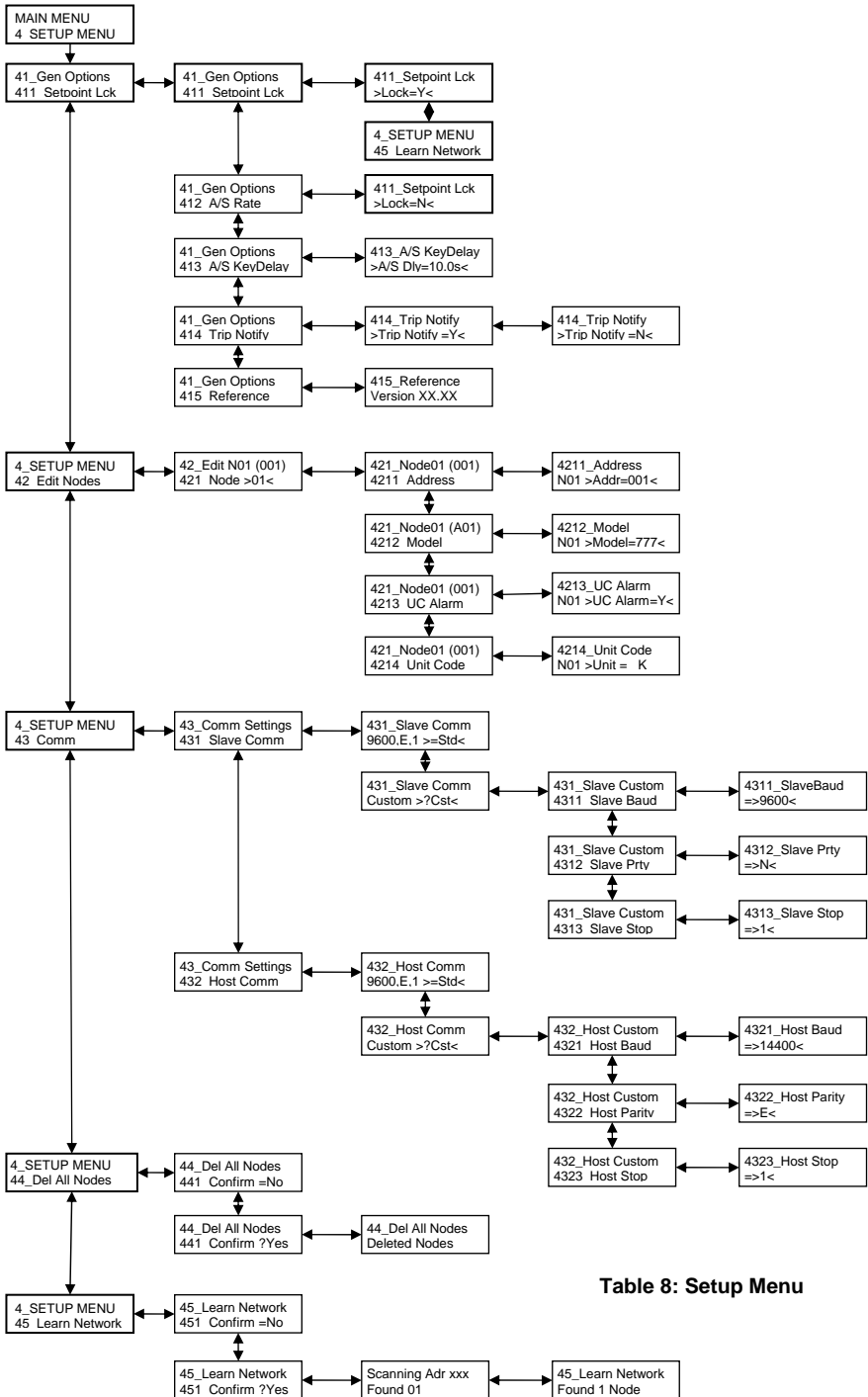

Table 8: Setup Menu

RM-1000 SPECIFICATIONS

Functional Characteristics	
Nominal Power Supply Voltage Rating Max Current	12-24VAC or VDC (isolated power source with maximum 4A overcurrent protection) 100mA
General Characteristics	
Environment	
Protection Class	NEMA 3R (NEMA 4X optional), IP44
Operating Temperature	-20° to 70°C
Storage Temperature	-30° to 80°C
Humidity	85% Non-condensing
Enclosure	
Dimensions	4.544" L x 3.619" W X 0.9" D
Weight	6 oz.
Material	Black Polycarbonate
UV Exposure w/o degradation	2000 hrs
Keypad Mechanical Lifetime	200,000 cycles
Keypad Material	Polyester
Panel Thickness	.03" min.
Terminal	Depluggable, Max Torque 3 in.-lbs.
Standards Passed	
Electrostatic Discharge (ESD)	IEC 61000-4-2, Level 3 (6kV contact, 8kV air discharge)
Electromagnetic field	IEC 61000-4-3, Level 3 (10 V/m)
Fast transient burst	IEC 61000-4-4, Level 4+ (4kV on cable clamp)
Surge	IEC 61000-4-5, 24V supply, Level 1 (±500V) RS-485 & Reset Lines, Level 2 (±1kV)
Conducted RF	IEC 61000-4-6, Level 3+ (30 V _{rms})
Voltage dips & interruptions	SEMI F47
Agency Approvals	
UL	UL 508
CE	IEC 60947-1, IEC 1131-2
Communications	
Baud Rate	1200 - 28800
Protocol	Modbus RTU
Serial Interface	RS-485
Range	50 ft. standard V+/- connection; 4000 ft. with isolated power supply.

ACCESSORIES

(Sold Separately)

The **RM-1000-ENCL** is a steel enclosure for protecting a SymCom RM-1000 remote communications monitor from adverse affects of weather and vandalism, while allowing normal communications connections to the RM-1000 unit. The enclosure unit mounts using the same hardware supplied with the RM-1000 unit.



Features:

- Sturdy steel construction
- Protects RM-1000 from harmful effects of UV sunlight
- Protects RM-1000 from harmful effects of hail
- Removable front cover for easy access when programming the RM-1000
- Securable with padlock

Visit us at www.symcom.com to see our complete product listing!

Need something special?

*Contact SymCom today
for your custom solution!
800-843-8848*