

## HOW TO REPLACE AN MPU-16A WITH AN MPU-32

The MPU-32 is compatible with existing MPU-16A installations. The MPU-32 and the MPU-16A have the same footprint and panel-mount method. The MPU-16A plug-in terminal-blocks will connect to the MPU-32. MPU-32 terminals are arranged to allow replacement of the MPU-16A with minimal wiring changes.

### 1. Before Removing the MPU-16A

Read this document and the MPU-32 manual before removing the MPU-16A.

Note the following settings:

MODE	FUNCTION	1 <sup>ST</sup> LEVEL SETTING	2 <sup>ND</sup> LEVEL SETTING
0	I <sup>2</sup> t Limit (s @ 600%)		
1	Overcurrent		
2	Undercurrent		
3	Current Unbalance (%)		
4	Temperature		
5	Earth Fault		
6	Full-Load Current		N/A
7	Service Factor (%)		N/A
8	Program		
F	CT Primary Ratings (A)		

Table 1: MPU-16A Settings

If the MPU-16A is monitoring a Resistive Temperature Detector (RTD) determine the type. The MPU-16A manual contains the RTD type; see MPU-16A manual page 2. If the RTD is not a platinum 100 Ω, an MPS-RTD Module is required.

# HOW TO REPLACE AN MPU-16A WITH AN MPU-32

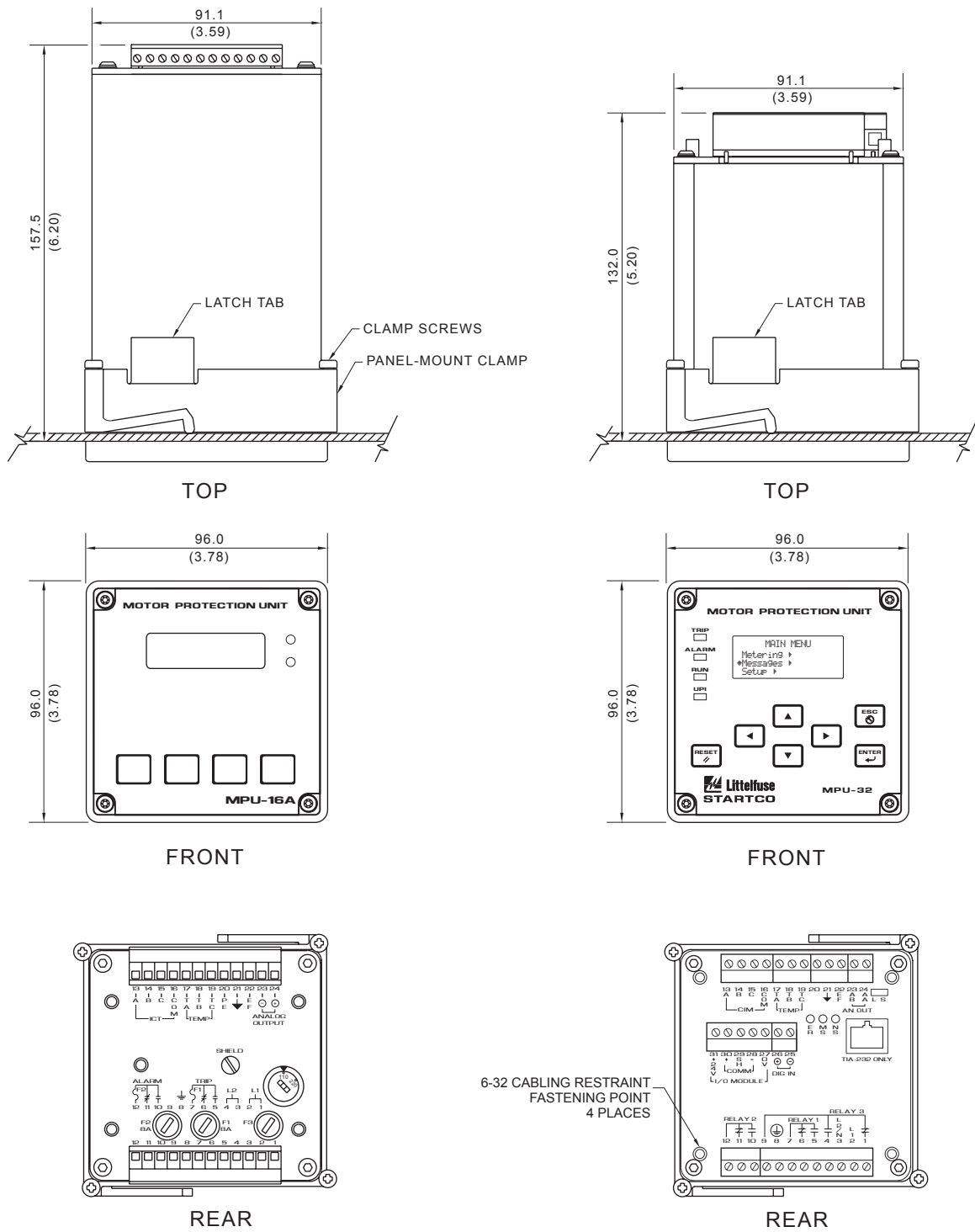

Figure 1: Physical Dimensions MPU-16A & MPU-32

## HOW TO REPLACE AN MPU-16A WITH AN MPU-32

### 2. Removing the MPU-16A from Service

Unplug the connectors from the back of the MPU-16A. The ICT-2 Interface Current Transformer terminates the CT's eliminating the need to short the CT secondaries. Loosen the four retaining screws of the panel-mount clamp. Lift the top and bottom latch tabs, and slide the clamp off the rear of the MPU-16A. See Fig. 1. Remove the MPU-16A from the panel.

### 3. Preparing to Install the MPU-32

#### TOP TERMINAL BLOCK, TERMINALS 13 – 24

No changes are necessary on the top terminal block if:

- program-change-enable switch is not used, and
- either a Platinum 100 Ω or no RTD is monitored.

PROGRAM CHANGE ENABLE FUNCTION	
MPU-16A	Jumper between terminals 20 and 21
MPU-32	Password or Digital Input

The MPU-16A requires a jumper to enable program changes and emergency thermal reset. MPU-32 program changes and emergency thermal reset are enabled with the digital input or by entering a password. To use a switch to enable program changes on the MPU-32, connect a normally open switch between terminals 31 and 26, and connect a jumper between terminals 25 and 27. Program the digital input as Program Enable.

4 - 20MA ANALOG OUTPUT	
MPU-16A	Terminals 23 and 24
MPU-32	Terminals 23 and 24

The 4 – 20 mA analog output is located on terminals 23 and 24 on the MPU-16A and MPU-32. Set the LS switch on the back plate of the MPU-32 to the S (self-powered) position. The analog output can be calibrated if desired.

#### MPU-32 TERMINALS 25-31

CABLE SHIELDING TERMINATION	
MPU-16A	Center of back plate
MPU-32	Terminal 29

Connect cable shielding to terminal 29 on the MPU-32

COMMUNICATIONS	
MPU-16A	Optional RS-485 Communication (Modbus or AB-DF1)
MPU-32	Standard TIA-232 (RJ-45 Socket), TIA-485 (Modbus RTU or AB-DF1) Optional

TIA-232 communications using the Modbus RTU protocol is a standard feature on the MPU-32. If the MPU-16A uses Modbus communications a TIA-232 to TIA-485 adapter can be used.

The MPU-32 standard interface is non-isolated. If an isolated Modbus RTU or AB DF-1 is required, use an MPU-32 with appropriate communications options.

## HOW TO REPLACE AN MPU-16A WITH AN MPU-32

### MPU-32 TERMINALS 1 - 12

**CAUTION:** Remove Red Keying Plug

The MPU-16A lower terminal block has a red keying plug inserted in the terminal 9 location to prevent reversing the upper and lower terminal blocks. Failure to remove this plug will result in damage to the MPU-32.

The red keying plug can be removed using a dental pick. If the keying plug will not come out remove the terminal block and use the terminal blocks supplied with the MPU-32.

The MPU-32 terminals are arranged to provide a third relay output at terminals 1, 4 and 9. The MPU-16A lower terminal block can be safely plugged into the MPU-32 lower terminal socket.

**CAUTION:** Do Not Reverse the Upper and Lower Terminal Blocks

Do not insert the MPU-16A lower terminal block into the MPU-32 upper terminal socket. Doing so will result in damage to the MPU-32.

#### OUTPUT CONTACTS

MPU-16A	Trip - terminals 5, 6, 7; Alarm - terminals 10, 11, 12
MPU-32	Relay 1 - terminals 5, 6, 7; Relay 2 - terminals 10, 11, 12; Relay 3 - terminals 1, 4, 9

The MPU-16A has 2 output relays, one for the alarm function and one for the trip function. The MPU-32 has 3 programmable output relays. The default relay assignment for the MPU-32 is: Relay1 – Trip1, Relay2 – Alarm1 and Relay3 – none.

#### CONTROL POWER

MPU-16A	L1-terminal 1 or 2, L2-terminal 3 or 4
MPU-32	L1-terminal 2, L2-terminal 3

Connect control power to MPU-32 terminals 2 and 3. If the duplicate supply terminals on the MPU-16A were used to power another device, reconnect that device directly to the power source.

### 4. Installing the MPU-32

Insert the MPU-32 into the panel cutout. Slide the panel-mount clamp onto the MPU-32 body until the latch tabs lock into the latch tab holes. See Fig. 1. If the MPU-32 is loose tighten the clamp screws.

### 5. Programming the MPU-32

Program the MPU-32 using the settings recorded in Table 1. See section 4 of the MPU-32 manual and section 3 of the MPU-16A manual. The JAM protection feature of the MPU-32 should be used to replace the OVERCURRENT setting from the MPU-16A.