

SENSITIVE GROUND-FAULT PROTECTION USING SPLIT-CORE CTs

A zero-sequence CT is optimized by using a symmetrical core and windings that are evenly spaced around the core. The symmetry allows the CT to operate in the presence of high load currents.

In a split-core CT, both the core and the secondary winding are not symmetrical which may result in nuisance tripping during high load-current conditions.

By using two split-core CTs, CT symmetry is improved allowing for reduced trip levels. The CTs should be fastened together as shown in Figure 1 with no gap between CTs and electrically connected as shown in Figure 2.

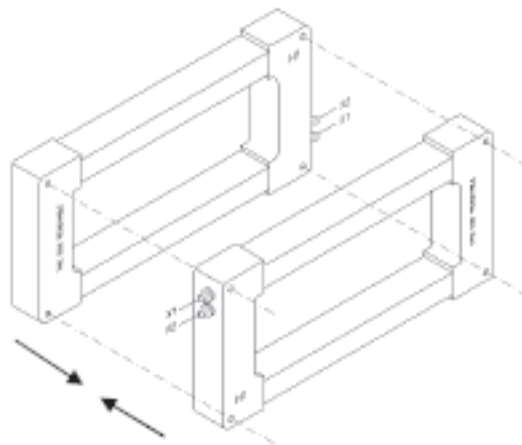

Figure 1: Mechanical Connection

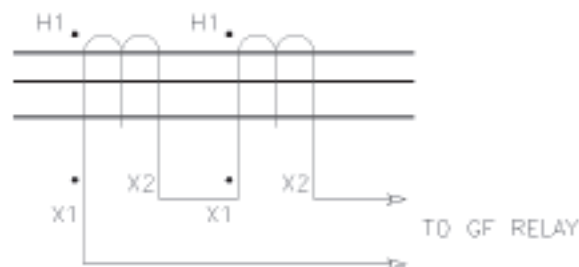

Figure 2: Electrical Connection