

Installation Instructions

SMZ Series Fuse Holder

Part Numbers: 0FHZ0231Z, 0FHZ0232Z, 0FHZ0233Z, 0FHZ0201Z, 0FHZ0202Z, 0FHZ0211Z, 0FHZ0212Z, 0FHZ0241Z

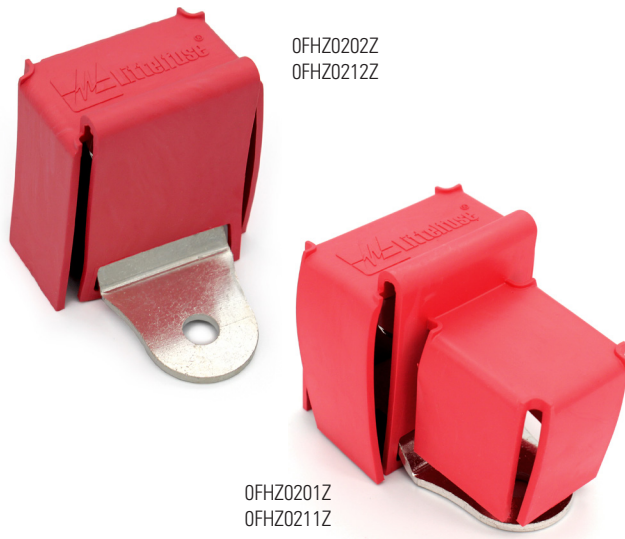

Description

The ZCASE® SMZ Series Bolt-Down Stud-Mount Fuse Holder reduces the need for wiring and parts by allowing ZCASE® high-current fuses to be directly installed on an alternator, battery switch, or electrical relay. Thanks to an insulated M8 or M10 stud on the busbar, the compatible fuse (sold separately) and output cable with a ring terminal (not included) can be assembled using the included standard nut. There is no need to buy a specialized nylon nut.

The SMZ Series M8 ZCASE® fuse holder is available with an M6, M8, or M10 mounting hole to meet the requirements of various applications, and the M10 ZCASE® fuse holder features an M10 mounting hole. Various configurations, including with a protective cover for the fuse only, with a protective cover for the fuse and mounting stud, and without a cover, are available.

Web Resources

Download datasheet, 2D print, 3D model and more at:
littelfuse.com/smz

Ordering Information

PART NUMBER	MOUNTING HOLE SIZE
0FHZ0231Z	M6 (6.5mm)
0FHZ0232Z	M6 (6.5mm)
0FHZ0233Z	M6 (6.5mm)
0FHZ0201Z	M8 (8.5mm)
0FHZ0202Z	M8 (8.5mm)
0FHZ0211Z	M10 (10.5mm)
0FHZ0212Z	M10 (10.5mm)
0FHZ0241Z	M10 (10.5mm)

Installation

Assemble the fuse holder and mount to the stud terminal in the following sequence:

1. The 0FHZ0201Z and 0FHZ0202Z are designed to be mounted on an input M8 or 5/16" stud. The 0FHZ0211Z and 0FHZ0212Z are designed to be mounted on an input M10 or a 3/8" stud. The outputs on both units use M8 or 5/16" studs.
2. Lift the cover on the output side of the holder. Place the appropriate ZCASE on the M8 output terminal.
3. Place an appropriate sized output cable with an M8 or 5/16" terminal on the top of the ZCASE fuses and place the included M8 nut on the isolated stud. Torque the nut to 14Nm ±2Nm. Be sure to hold the wire and ring terminal while applying torque. This will prevent excessive torque from damaging the fuse element.
 - Remember when selecting fuse values the continuous current through a fuse should be calculated as 75% of the rated value of the fuse (200A fuse should carry 150A max continuous current).
 - The total long term continuous current for all fuses should not exceed 400A per holder.
 - Intermittent loads such as motor start, starter or compressor should not exceed 600A for 20 seconds.
4. Up to three holders can be stacked on a single input stud. Use either the 0FHZ0202Z or 0FHZ0212Z for all except the top unit in a stack so that the cover does not interfere with the stacking. Make sure to use a nut and lock washer or nut with locking features. Torque nut to proper range defined by the maker of the device to which you are mounting the holder. Make sure that the stud is long enough that a minimum of two full threads show above the nut when it is torqued in place.
5. Be sure that the output cables are routed so they have sufficient bend radius and are not at risk of being damaged or pinched. Lastly, make sure that all cables are strain relieved by being supported within 18" of the battery.

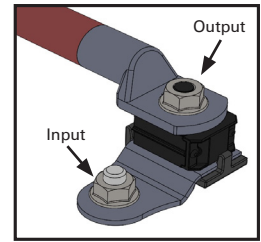

Step by step images shown in Figure 2 on page 2.

Figure 1 - Finished Covered Assembly

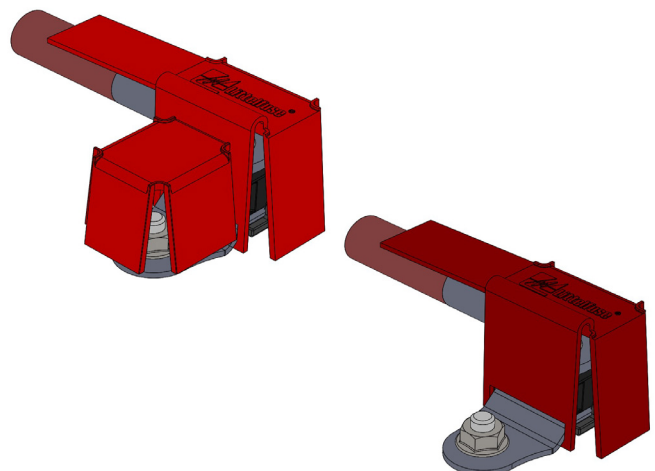

Installation Instructions SMZ Series Fuse Holder

Part Numbers: 0FHZ0231Z, 0FHZ0232Z, 0FHZ0233Z, 0FHZ0201Z, 0FHZ0202Z, 0FHZ0211Z, 0FHZ0212Z, 0FHZ0241Z

Figure 2 - Step by Step Installation

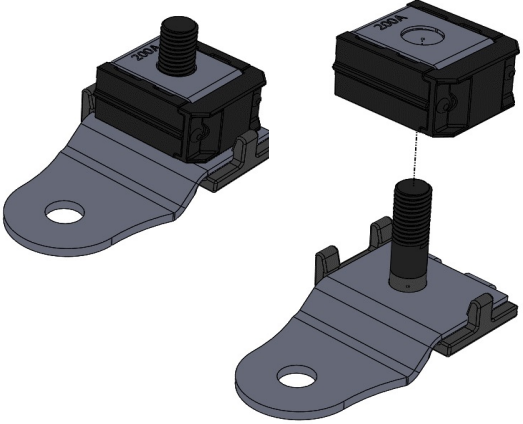
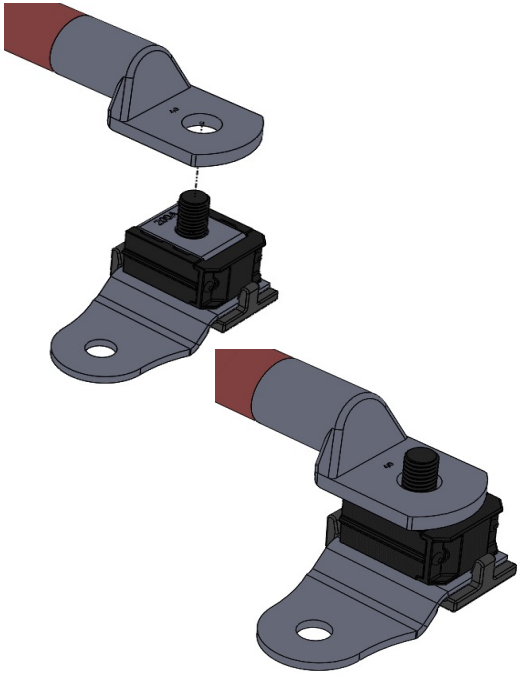
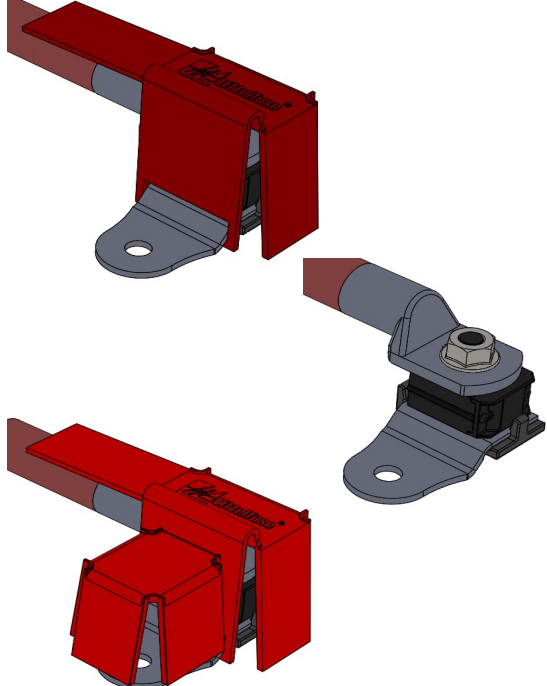
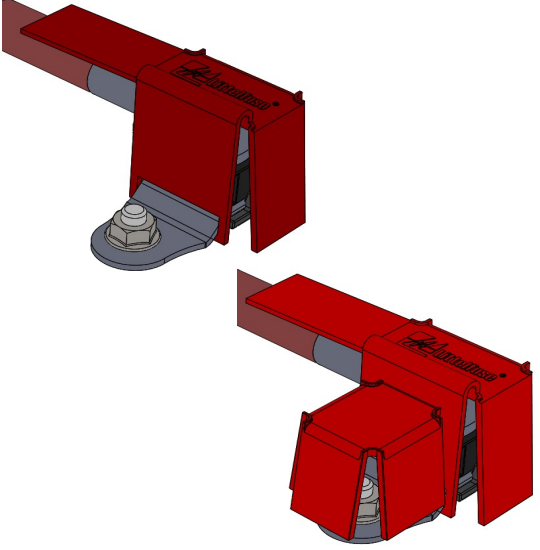
STEP 1	IMAGE	
	DETAILS	Place the ZCASE fuse over the terminal M8 stud.
STEP 2	IMAGE	
	DETAILS	Place output cable with an M8 or 5/16" ring terminal on top of the ZCASE fuse.
STEP 3	IMAGE	
	DETAILS	Secure M8 Nut to stud. (14Nm±2Nm). Hold the wire and terminal while applying torque to prevent twisting.
STEP 4	IMAGE	
	DETAILS	Bolt to M8 or M10 Mounting Stud.

Specifications, descriptions and illustrative material in this literature are as accurate as known at the time of publication, but are subject to changes without notice. Visit littelfuse.com for the most up-to-date technical information.