

SE-330 MANUAL

NEUTRAL-GROUNDING-RESISTOR MONITOR

REVISION 9-A-112913

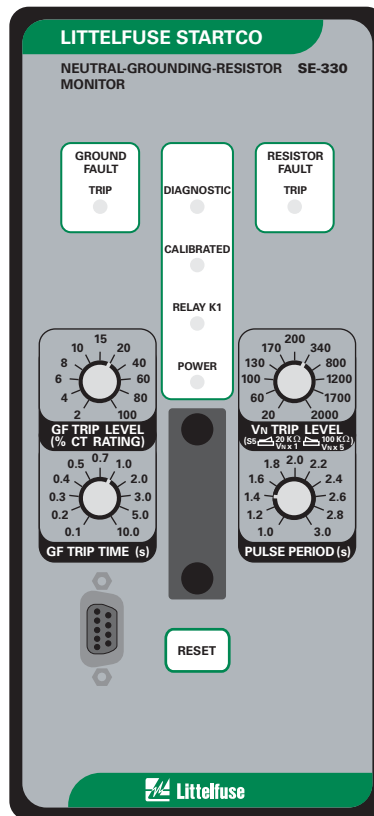

Copyright © 2013 Littelfuse Startco

All rights reserved.

TABLE OF CONTENTS

	PAGE
1. General	1
1.1 Modern Resistance-Grounded Systems	1
1.2 SE-330 NGR Monitoring	1
2. Operation	2
2.1 Settings	2
2.1.1 GF Trip Time	2
2.1.2 GF Trip Level	2
2.1.3 V _N Trip Level	2
2.1.4 Pulse-Period Adjustment	3
2.1.5 Configuration Settings	3
2.1.5.1 Relay K1 Function (S1)	4
2.1.5.2 Trip-Relay Mode and Trip Memory Mode(S2)	4
2.1.5.3 Ground-Fault-Trip Latch (S3).....	4
2.1.5.4 Resistor-Fault-Trip Latch (S4).....	4
2.1.5.5 Sensing-Resistor Selection (S5).....	4
2.1.5.6 Frequency (S6).....	4
2.1.5.7 Spare (S7)	4
2.1.5.8 Upgrade Enable (S8).....	4
2.2 Calibration	4
2.3 Pulsing Operation	4
2.4 Trip Indication and Reset.....	5
2.5 Remote Operation.....	5
2.6 Relay K1 LED	5
2.7 Unit Healthy Output	5
2.8 Diagnostic LED	5
2.9 Analog Output	6
3. Installation	6
3.1 SE-330	6
3.2 Sensing Resistor.....	12
3.3 Ground-Fault CT	20
3.4 Isolated Ground Connection	24
3.5 Pulsing Connection	25
4. Communications	25
4.1 Local Communications Port	25
4.1.1 Local Data Acquisition	25
4.1.2 Local Communications Commands.....	25
4.1.3 Firmware Upgrade.....	25
4.2 Network Communications	25
5. Troubleshooting	26
6. Technical Specifications	27
6.1 SE-330	27
6.2 Sensing Resistors	28
6.3 Current Sensors.....	29
7. Ordering Information	29

	PAGE
8. Warranty	30
9. Test Procedures	31
9.1 Resistor-Fault Tests	31
9.1.1 Calibration and Open Test	31
9.1.2 Voltage Test	31
9.2 Sensing-Resistor Test	31
9.3 Analog-Output Test	31
9.4 Ground-Fault Performance Test	32

LIST OF FIGURES

FIGURE		PAGE
1	Configuration Switches	3
2	Analog-Output Connections	6
3	SE-330 Connection Diagram	7
4	SE-330 Outline and Panel-Mounting Details	8
5	SE-330 Outline and Surface-Mounting Details	9
6	SE-IP65CVR-G Weatherproof Cover Outline	10
7	SE-IP65CVR-G Weatherproof Cover Installation	11
8	ER-600VC Sensing Resistor	12
9	SE-MRE-600 Moisture-Resistant Enclosure Outline	13
10	SE-MRE-600 with installed ER-600VC.....	14
11	ER-5KV Sensing Resistor	15
12	ER-5WP Sensing Resistor	16
13	ER-15KV Sensing Resistor	17
14	ER-25KV Sensing Resistor	18
15	ER-35KV Sensing Resistor	19
16	EFCT-1 Ground-Fault Current Sensor	21
17	SE-CS30-70 Ground-Fault Current Sensor	22
18	EFCT-26 and SE-CS30-26 Ground-Fault Current Sensors	23
19	RK-332 Remote Indication and Reset	24
20	Simplified Isolated-Ground Connection.....	24
21	Simplified Pulsing Connection.....	25
22	Ground-Fault-Test Circuits	33

LIST OF TABLES

TABLE		PAGE
1	Typical Values for Tripping Systems	3
2	Ground-Fault Trip Levels for Selected CT's.....	3
3	RS-232 DB-9 Terminals.....	25
4	Ground-Fault-Test Record.....	33

DISCLAIMER

Specifications are subject to change without notice. Littelfuse Startco is not liable for contingent or consequential damages, or for expenses sustained as a result of incorrect application, incorrect adjustment, or a malfunction.

1. GENERAL

1.1 MODERN RESISTANCE-GROUNDED SYSTEMS

A high-resistance-grounded system uses a neutral-grounding resistor (NGR) with a low let-through current to limit ground-fault current. This is an improvement over low-resistance or solidly-grounded systems because, in those systems, a ground-fault flash hazard exists and a ground fault can result in substantial point-of-fault damage. High-resistance grounding eliminates these problems and modern ground-fault protection operates reliably at low current levels. Furthermore, the probability of an arc-flash incident is significantly reduced in a high-resistance-grounded system.

NGR selection depends on system charging current and whether the system is an alarm-only or a tripping system. Alarm-only systems are usually restricted to system voltages up to 5 kV with NGR let-through currents of 5 A or less. Occasionally, alarm-only systems up to 15 kV and up to 10 A are used; however, they are not common because a ground fault on such a system tends to escalate to a phase-to-phase fault before the ground fault can be located and cleared.

System charging current is the capacitive current that flows to ground when a bolted ground fault occurs. This current can be calculated or measured. For small systems, the magnitude of charging current can be conservatively estimated as $\frac{1}{2}$ A per 1,000 kVA on low-voltage systems and 1 A per 1,000 kVA on medium-voltage systems.

In an alarm-only system or in a tripping system without selective coordination, choose an NGR with a let-through current larger than the system charging current and set the pick-up current of ground-fault devices at or below 50% of the NGR let-through current.

In a tripping system with selective coordination, use ground-fault devices with a definite-time characteristic to achieve time coordination. Use the same pick-up current for all ground-fault devices—this value must be larger than the charging current of the largest feeder. Select an NGR with a let-through current between five and ten times the pick-up current of the ground-fault devices.

Do not use a grounding transformer with a low-voltage resistor:

- The combined cost of a transformer and a low-voltage resistor is more than the cost of a resistor rated for line-to-neutral voltage.
- A transformer saturated by a ground fault through a rectifier can make ground-fault protection inoperative.
- Transformer inrush current up to twelve times rated current can cause a ground-fault voltage larger than expected.
- A parallel transformer winding makes it difficult to monitor NGR continuity.
- A transformer can provide the inductance necessary to cause ferroresonance if the NGR opens.

Following these guidelines will reduce the flash hazard, reduce point-of-fault damage, achieve reliable ground-fault protection, and ensure a stable system not subject to ferroresonance.

1.2 SE-330 NGR MONITORING

The SE-330 is a microprocessor-based neutral-grounding-resistor monitor that detects NGR failures and ground faults in resistance-grounded systems. The SE-330 measures NGR resistance, NGR current, and transformer or generator neutral-to-ground voltage. The components required to monitor an NGR are an SE-330, a 20- or 100-k Ω ER-series sensing resistor, and a current transformer (CT).

Power-circuit elements, other than neutral-connected NGR's, that purposefully connect the power system to ground are often not compatible with SE-330 NGR monitoring. These elements include single-phase grounding transformers, grounded-wye-primary PT's, and grounded-wye-primary power transformers.

The SE-330 continuously measures NGR resistance in an unfaulted system, and it will trip on resistor fault if NGR resistance varies from its calibrated value. When a ground fault occurs, voltage is present on the neutral and NGR current will flow if the NGR is healthy. The SE-330 will trip on ground fault if fault current exceeds the GF TRIP LEVEL setting for an interval equal to the GF TRIP TIME setting. However, if the NGR fails open during a ground fault, it is possible for fault resistance to satisfy the NGR resistance measurement. To detect this double-fault condition, the SE-330 measures neutral voltage. If neutral voltage exceeds the V_N TRIP LEVEL setting, and if NGR current is less than 5% of the CT rating, the SE-330 will trip on resistor fault. If the resistor-fault circuit is tripped and the neutral voltage exceeds the V_N TRIP LEVEL setting for an interval greater than the GF TRIP TIME setting, the ground-fault circuit will also trip.

Ground-fault current is sensed by a CT with a 1- or 5-A secondary, or by a sensitive CT (EFCT-x or SE-CS30-x) with a 50-mA secondary. The trip level of the ground-fault circuit is adjustable from 2 to 100% of the CT rating and trip time is adjustable from 0.1 to 10.0 seconds.

The SE-330 has four output relays. Relay K1 can be assigned a trip or a pulsing function. Relays K2 and K3 provide ground-fault and resistor-fault indication. K4 is a solid-state relay that provides UNIT HEALTHY indication. When relay K1 is assigned the trip function, it will operate on either a resistor fault or ground fault, and it can be set to operate in the fail-safe or non-fail-safe mode for undervoltage or shunt-trip applications. When the pulsing function is selected, relay K1 is used to control a contactor to assist in fault location.

Additional features include LED trip indication, trip memory, front-panel and remote reset, 4–20-mA analog output, RS-232 local communications, data logging, and optional network communications.

The SE-330 provides additional features and improved performance over the SE-325 NGR Monitor:

- SE-330 dc rejection is sufficient for reliable operation in overhead-line applications.
- Digital filtering of voltage and current signals minimizes false trips due to harmonics.
- Resistance measurement is calibrated to the NGR to achieve a lower trip resistance.
- Broader setting ranges.
- Independent ground-fault and resistor-fault relays can be used for indication and control.
- Universal power supply.
- Wider CT-selection range.
- Network communications options provide information to a distributed control system.
- 4–20 mA analog output.
- UNIT HEALTHY output contact.
- Power-up trip memory.
- Pulsing capability can be used on low- and medium-voltage systems to assist in locating ground faults.
- RS-232 local communications port for firmware upgrades and access to SE-330 measured parameters.

2. OPERATION

2.1 SETTINGS

2.1.1 GF TRIP TIME

GF TRIP TIME (definite time) is adjustable from 0.1 to 10.0 seconds. Time-coordinated ground-fault protection requires this setting to be longer than the trip times of downstream ground-fault devices.

A trip-time accumulator provides a ground-fault memory function for detection of intermittent faults. The accumulated time increases when a ground fault is detected and decreases when a ground fault is not detected. A trip will eventually occur when the time for fault current above the trip level is greater than the time for fault current below the trip level.

2.1.2 GF TRIP LEVEL

The SE-330 uses a Discrete-Fourier Transform (DFT) algorithm to measure the fundamental component of NGR current.

Choose an NGR let-through current and a ground-fault trip level according to the guidelines in Section 1.1. Set the ground-fault trip level as a percentage (2, 4, 6, 8, 10, 15, 20, 40, 60, 80, or 100) of the CT-primary rating. Inputs are provided for 5-, 1-, and 0.05-A-secondary CT's. Typical values for 5-, 15-, and 25-A tripping systems are shown in Table 1. Ground-fault trip levels for selected CT's are shown in Table 2. For other systems, refer to the NGR Monitor Set-Point Assistant at www.littelfuse.com/protectionrelays.

2.1.3 V_N TRIP LEVEL

The SE-330 uses a DFT algorithm to measure the fundamental component of neutral voltage.

Calculate the voltage across the NGR when NGR current is equal to the pick-up current of the ground-fault circuit. Set the V_N TRIP LEVEL at the next largest value. The V_N TRIP LEVEL range is 20 to 2,000 V with switch S5 in the 20-k Ω (Vx1) position, and the range is 100 to 10,000 V with switch S5 in the 100-k Ω (Vx5) position. See Fig. 1 and Section 2.1.5.5.

If neutral voltage is greater than the V_N TRIP LEVEL setting for 12 seconds and ground-fault current is less than 5% of the CT rating, the SE-330 will trip on resistor fault. If the resistor-fault circuit is tripped and the neutral voltage exceeds the V_N TRIP LEVEL setting for an interval greater than the GF TRIP TIME setting, the ground-fault circuit will also trip.

Typical values for 5-, 15-, and 25-A tripping systems are shown in Table 1. For an NGR resistance greater than 2 k Ω , use a 100-k Ω sensing resistor. For other systems, refer to the NGR Monitor Set-Point Assistant at www.littelfuse.com/protectionrelays.

NOTE: A resistor-fault trip is held off if the ground-fault current is above 5% of the CT rating.
--

TABLE 1. TYPICAL VALUES FOR TRIPPING SYSTEMS

System Voltage (Volts)	Neutral-Grounding Resistor		Sensing Resistor		Ground-Fault Trip Level (Amperes)	V _N Trip Level (Volts)
	Current (Amperes)	Resistance (Ohms)	Model	Resistance (Switch S5 Setting)		
480	5	55	ER-600VC	20 kΩ	1.0	60
600	5	69	ER-600VC	20 kΩ	1.0	100
2,400	5	277	ER-5KV	20 kΩ	1.0	340
4,160	5	480	ER-5KV	20 kΩ	1.0	800
480	15	18	ER-600VC	20 kΩ	3.0	60
600	15	23	ER-600VC	20 kΩ	3.0	100
2,400	15	92	ER-5KV	20 kΩ	3.0	340
4,160	15	160	ER-5KV	20 kΩ	3.0	800
7,200	15	277	ER-15KV	100 kΩ	3.0	170x5=850
14,400	15	554	ER-15KV	100 kΩ	3.0	340x5=1,700
4,160	25	96	ER-5KV	20 kΩ	5.0	800
7,200	25	166	ER-15KV	100 kΩ	5.0	170x5=850
14,400	25	332	ER-15KV	100 kΩ	5.0	340x5=1,700
25,000	25	577	ER-25KV	100 kΩ	5.0	800x5=4,000
35,000	25	808	ER-35KV	100 kΩ	5.0	1,200x5=6,000

TABLE 2. GROUND-FAULT TRIP LEVELS FOR SELECTED CT'S

GF TRIP LEVEL (%)	EFCT-x 5:0.05 (Amperes)	SE-CS30-x 30:0.05 (Amperes)	50:1 50:5 (Amperes)	100:1 100:5 (Amperes)	200:1 200:5 (Amperes)	400:1 400:5 (Amperes)
2	0.10	0.60	*	*	*	*
4	0.20	1.20	*	*	*	16
6	0.30	1.80	*	*	12	24
8	0.40	2.40	*	8	16	36
10	0.50	3.00	5	10	20	40
15	0.75	4.50	7.5	15	30	60
20	1.00	6.00	10	20	40	80
40	2.00	12.0	20	40	80	160
60	3.00	18.0	30	60	120	240
80	4.00	24.0	40	80	160	320
100	5.00	30.0	50	100	200	400

* Setting not recommended.

2.1.4 PULSE-PERIOD ADJUSTMENT

Pulse period is the cycle time of relay K1 when the SE-330 is configured for pulsing operation. Pulse period is adjustable from 1.0 to 3.0 seconds with a fixed duty cycle of 50%. For example, with the 1.0-s setting, relay K1 will alternately be energized for 0.5 seconds and de-energized for 0.5 seconds when pulsing is enabled.

NOTE: For pulsing configuration, set switch S1 to K1 = PULSING and install an external pulse-enable switch.

2.1.5 CONFIGURATION SETTINGS

Eight configuration switches (S1 to S8) and a calibration push button are located behind the access cover on the front panel. See Fig. 1.

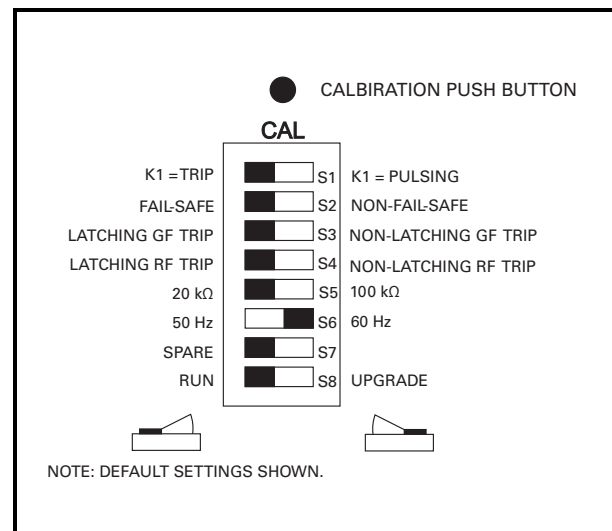

FIGURE 1. Configuration Switches.

2.1.5.1 RELAY K1 FUNCTION (S1)

Set switch S1 to K1 = TRIP to assign the trip function to relay K1 and to activate switch S2. Relay K1 will change state when a resistor-fault or ground-fault trip occurs.

Set switch S1 to K1 = PULSING to configure relay K1 for pulsing operation. See Section 2.3.

2.1.5.2 TRIP-RELAY MODE AND TRIP MEMORY MODE (S2)

Set switch S2 to select the operating mode of trip relay K1. In the non-fail-safe mode, relay K1 energizes and its contact closes when a trip occurs. The non-fail-safe mode can be used to trip shunt-trip circuit breakers. In the non-fail-safe mode, SE-330 trips are reset when supply voltage is cycled.

In the fail-safe mode, relay K1 energizes and its contact closes if there are no trips. Contacts open if there is a trip, a loss of supply voltage, or a processor failure. In the fail-safe mode, SE-330 trips are not reset when supply voltage is cycled.

NOTE: Switch S2 does not affect the operating modes of relays K2, K3, and K4.

NOTE: Switch S2 only affects relay K1 operating mode when K1 is assigned the trip function (switch S1 set to K1 = TRIP). Switch S2 defines SE-330 trip memory regardless of the switch S1 setting.

2.1.5.3 GROUND-FAULT-TRIP LATCH (S3)

Set switch S3 to select latching or non-latching ground-fault-circuit operation. Non-latching operation defeats ground-fault-trip memory. See Sections 2.1.5.2 and 2.4.

2.1.5.4 RESISTOR-FAULT-TRIP LATCH (S4)

Set switch S4 to select latching or non-latching resistor-fault-circuit operation. Non-latching operation defeats resistor-fault-trip memory. See Sections 2.1.5.2 and 2.4.

2.1.5.5 SENSING-RESISTOR SELECTION (S5)

Set switch S5 to the resistance of the sensing resistor. For the ER-600VC and ER-5KV, select 20 k Ω . For the ER-15KV, ER-25KV, and ER-35KV, select 100 k Ω . Switch S5 sets the resistor-fault trip value and the V_N TRIP LEVEL range. See Section 2.1.3.

2.1.5.6 FREQUENCY (S6)

Set switch S6 to 50 or 60 Hz to tune the digital filter to the line frequency of the monitored system.

2.1.5.7 SPARE (S7)

2.1.5.8 UPGRADE ENABLE (S8)

Set switch S8 to RUN for normal operation or to UPGRADE to enable firmware upgrades. Changes in switch S8 settings are recognized only when supply

voltage is cycled. Protection is disabled after supply voltage is cycled with S8 in the UPGRADE position. See Section 4.1.3.

2.2 CALIBRATION

The SE-330 measures the resistance change of the NGR relative to the NGR-resistance value determined at the time of calibration. Calibrate the SE-330 on new installations, if the NGR is changed, or if the sensing resistor is changed.

NOTE: If the SE-330 is not calibrated and is supplied from the load side of the breaker (non-fail-safe mode), calibrate within 12 seconds of power-up or it may trip and interrupt its supply.

The CALIBRATION push button is located behind the access cover on the front panel, and it is recessed to prevent inadvertent activation.

NOTE: Calibration must be performed with the SE-330 connected to the sensing resistor and NGR of the installed system.

To calibrate, press and hold the CALIBRATION push button until the green CALIBRATED LED turns off and returns to on (if the LED is already off, press and hold until the LED turns on). Calibration takes approximately two seconds. If calibration is not successful, a resistor-fault trip occurs, the RESISTOR FAULT TRIP LED will be on, the CALIBRATED LED will be off, and the DIAGNOSTIC LED will flash the calibration-error code. See Section 2.8.

If latching resistor fault (switch S4) is selected, the calibration-error code flashes until RESET is pressed even if the CALIBRATED LED is on.

The calibration value is stored in non-volatile memory.

2.3 PULSING OPERATION

If switch S1 is set to K1 = PULSING, pulsing occurs when terminal 16 is connected to terminal 17. Relay K1 operates at a 50% duty cycle and cycle time is adjustable from 1.0 to 3.0 seconds. When terminals 16 and 17 are not connected, K1 is not energized and its contact is open.

Relay K1 can be used to control a contactor rated for use at the line-to-neutral voltage. The contactor causes changes in neutral-to-ground resistance by adding or shorting portions of the NGR. See Section 3.5. Pulsing ground-fault current appears as zero-sequence current upstream from the fault.

Pulsing ground-fault current is distinguishable from charging current and noise, and it can be traced with a clip-on ammeter or current probe. If pulsing current is detected on a cable or conduit, the fault is downstream. Systematic testing allows faults to be located without isolating feeders or interrupting loads. If the fault is on a conduit system with a complex mix of cables and ground points, the exact location of the ground fault may be difficult to determine.

Stop pulsing when the fault is located.

2.4 TRIP INDICATION AND RESET

Red LED's and indication relays indicate ground-fault and resistor-fault trips—indication relays K2 and K3 are energized on trip. When a trip occurs with latching operation selected, the SE-330 remains tripped until reset. See Sections 2.1.5.3 and 2.1.5.4. Terminals 15 and 16 are provided for remote reset as shown in Fig. 3. The reset circuit responds only to a momentary closure so that a jammed or shorted switch does not prevent a trip. The front-panel RESET switch is inoperative when terminal 15 is connected to terminal 16. If non-latching operation is selected, trips and corresponding indication automatically reset when the fault clears and power-up trip memory is defeated even when configuration switch S2 is set to fail-safe. Automatic reset time is 2.8 s, maximum.

The red DIAGNOSTIC LED annunciates latched calibration-error and remote trips. See Section 2.8.

When supply voltage is applied with switch S2 set to FAIL-SAFE, the SE-330 returns to its state prior to loss of supply voltage unless switch S3 or S4 is set to non-latching. When supply voltage is applied with switch S2 set to NON-FAIL-SAFE, SE-330 trips are reset. When a local, remote, or network reset is issued, both trip LED's will flash if they are off.

Resistor-fault-trip reset can take up to one second. Resistor-fault trip-memory trip can take up to three seconds after SE-330 power up.

2.5 REMOTE OPERATION

Relays K2 and K3 can be used for remote indication, and terminals 15 and 16 are provided for remote reset. RK-332 Remote Indication and Reset components are shown in Fig. 19. Connect them as shown in Fig. 3. RK-332 components are not polarity sensitive.

Network-enabled SE-330's can be remotely tripped and reset by the network master. The red DIAGNOSTIC LED indicates a network-initiated trip. See Section 2.8. Refer to the appropriate SE-330 communications manual.

2.6 RELAY K1 LED

The yellow RELAY K1 LED follows the state of relay K1 and is on when K1 is energized (contact closed).

2.7 UNIT HEALTHY OUTPUT

UNIT HEALTHY relay K4 is energized when the processor is operating. It can be ordered with N.O. or N.C. contacts. See Section 7.

NOTE: The K4 output changes state momentarily during a processor reset.

NOTE: K4-contact rating is 100 mA maximum.

2.8 DIAGNOSTIC LED

The DIAGNOSTIC LED is used to annunciate trips without individual LED indication. The number of short LED pulses between pauses indicates the cause of the trip.

Calibration-Error Trip (1 short):

The calibration resistance of the NGR is outside the calibration range. See Section 6.1.

Remote Trip (2 short):

The SE-330 has been tripped by a remote-trip command from the communications interface.

EEPROM-Error Trip (3 short):

An EEPROM error has been detected.

A/D-Converter-Error Trip (4 short):

An A/D-converter error has occurred.

Software-Interrupt Trip (5 short):

CPU reset was caused by a software interrupt.

Illegal-Opcode Trip (6 short):

CPU reset was caused by an illegal Opcode.

Watchdog Trip (7 short):

CPU reset was caused by the watchdog.

Clock-Failure Trip (8 short):

CPU reset was caused by an internal clock failure.

CPU Trip (9 short):

This code is displayed if the supply is cycled after one of the previous four errors occurred.

Resistor-fault trips occur with all of the above trips. Ground-fault trips occur with all of the above trips except the calibration-error trip and the A/D-converter-error trip. See Troubleshooting Section 5.

2.9 ANALOG OUTPUT

An isolated 4–20-mA output indicates NGR current with full-scale output corresponding to the CT rating. An internal 24-Vdc supply allows the analog output to be connected as a self-powered output. Power from an external supply is required for loop-powered operation. See Fig. 2.

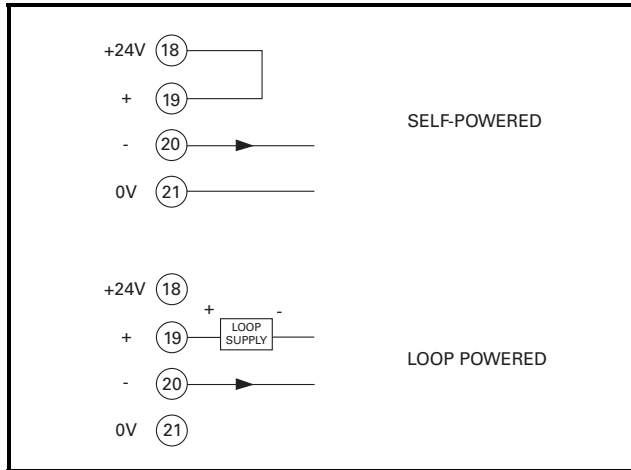

FIGURE 2. Analog-Output Connections.

3. INSTALLATION

3.1 SE-330

Outline and panel-cutout dimensions for the SE-330 are shown in Fig. 4. To panel mount the SE-330, insert it through the panel cutout and secure it with four 8-32 locknuts and flat washers (included).

If an optional SE-IP65CVR-G Hinged Cover is used, follow the included installation instructions. See Figs 6 and 7.

All connections to the SE-330 are made with plug-in, wire-clamping terminal blocks. Each plug-in terminal block can be secured to the monitor by two captive screws for reliable connections.

Outline dimensions and mounting details for surface mounting the SE-330 are shown in Fig. 5. Fasten the surface-mount adapter to the mounting surface and make connections to the adapter terminal blocks. Follow Fig. 5 instructions to mount or remove the SE-330.

Ground terminal 7 (G) and connect terminal 6 (R) to the sensing-resistor R terminal.

Use terminal 1 (L1) as the line terminal on ac systems, or the positive terminal on dc systems. Use terminal 2 (L2/N) as the neutral terminal on ac systems or the negative terminal on dc systems. Connect terminal 3 (⊕) to ground. Connect terminal 4 (SPG) to terminal 5 (SPGA). Remove the terminal-4-to-5 connection for dielectric-strength testing.

NOTE: When the terminal-4-to-5 connection is removed, protective circuits inside the SE-330 are disconnected to allow dielectric strength testing of a control panel without having to disconnect wiring to the SE-330. Ensure that the terminal-4-to-5 connection is replaced after testing.

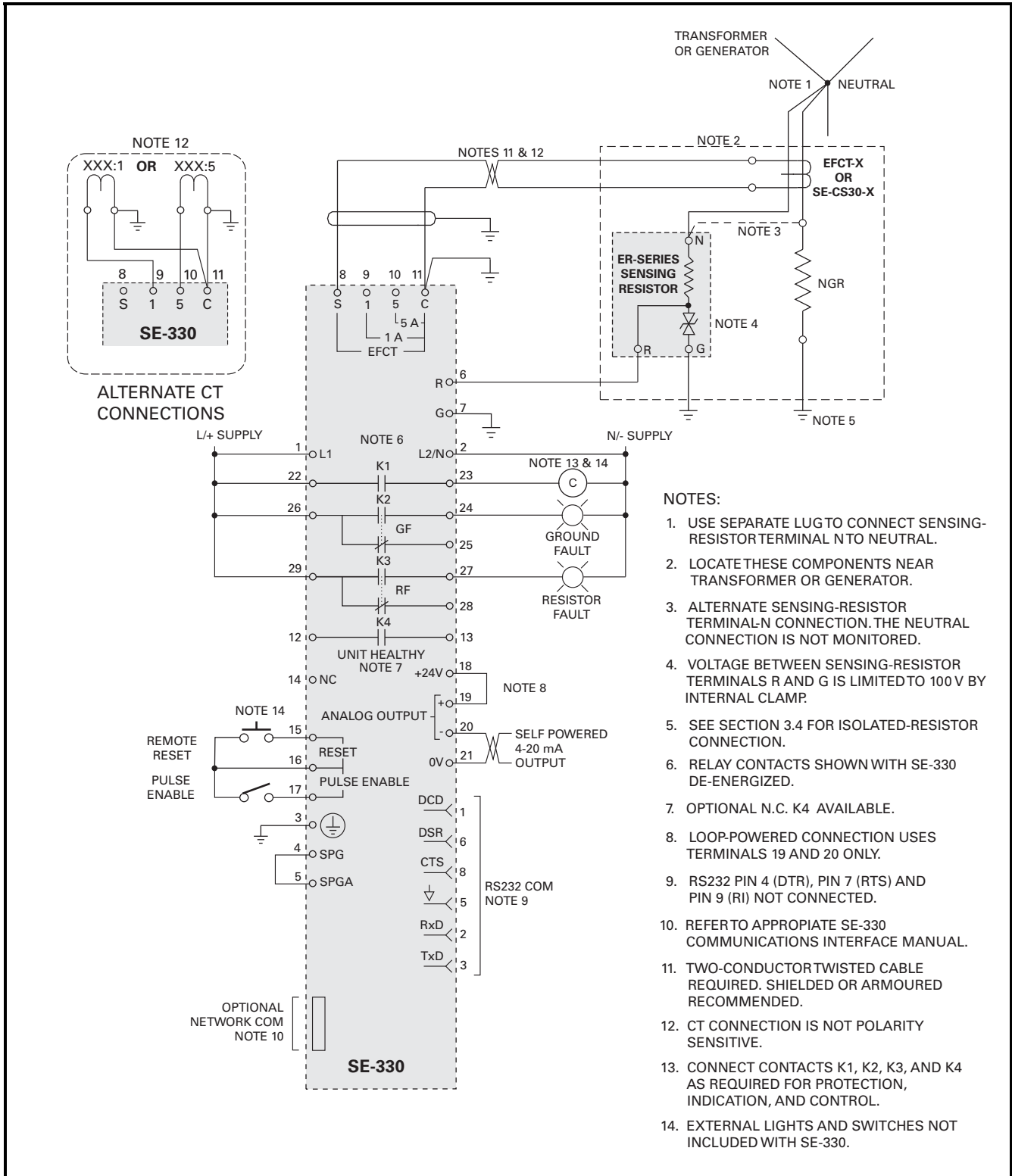
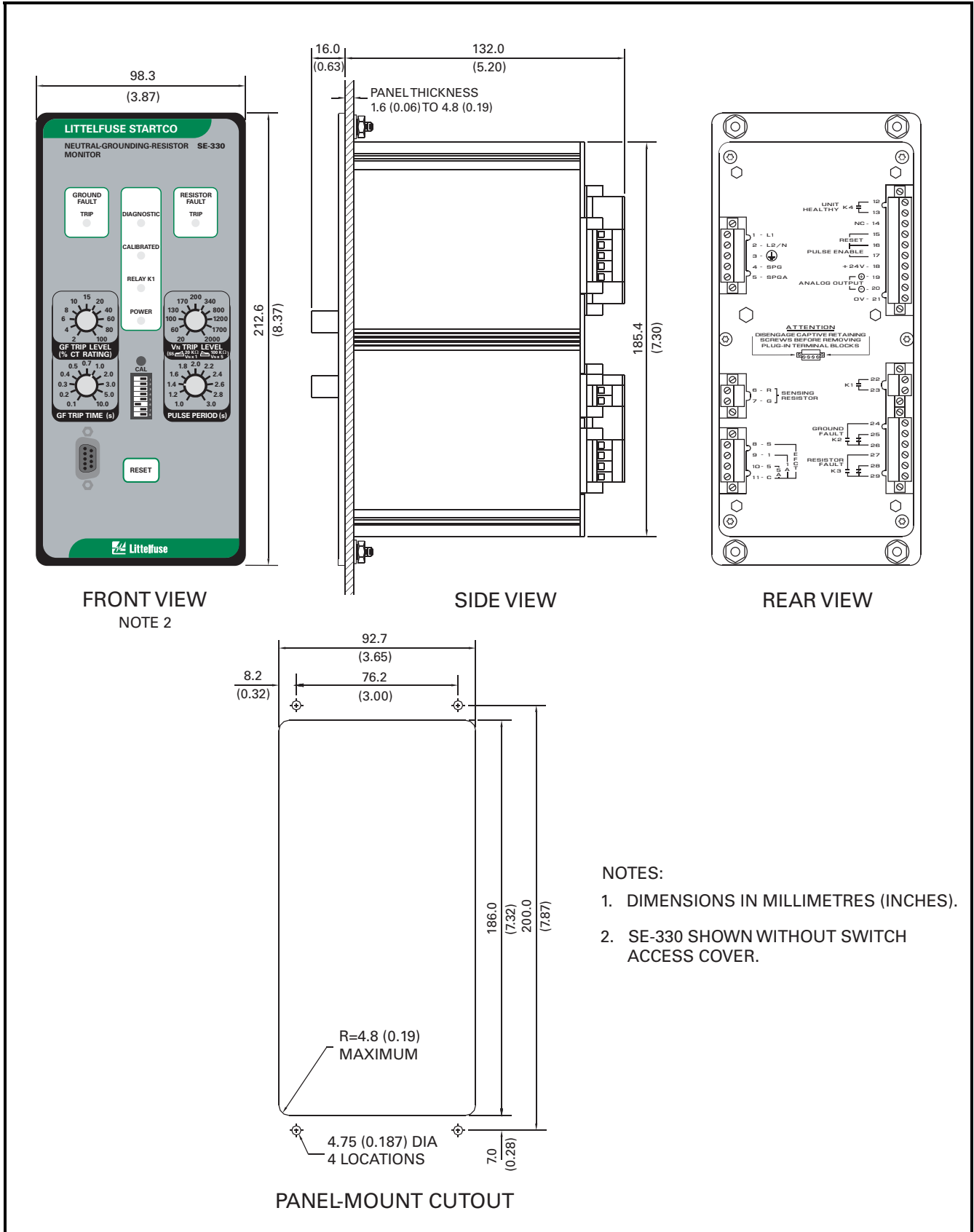

FIGURE 3. SE-330 Connection Diagram.



- NOTES:
1. DIMENSIONS IN MILLIMETRES (INCHES).
 2. SE-330 SHOWN WITHOUT SWITCH ACCESS COVER.

FIGURE 4. SE-330 Outline and Panel-Mounting Details.

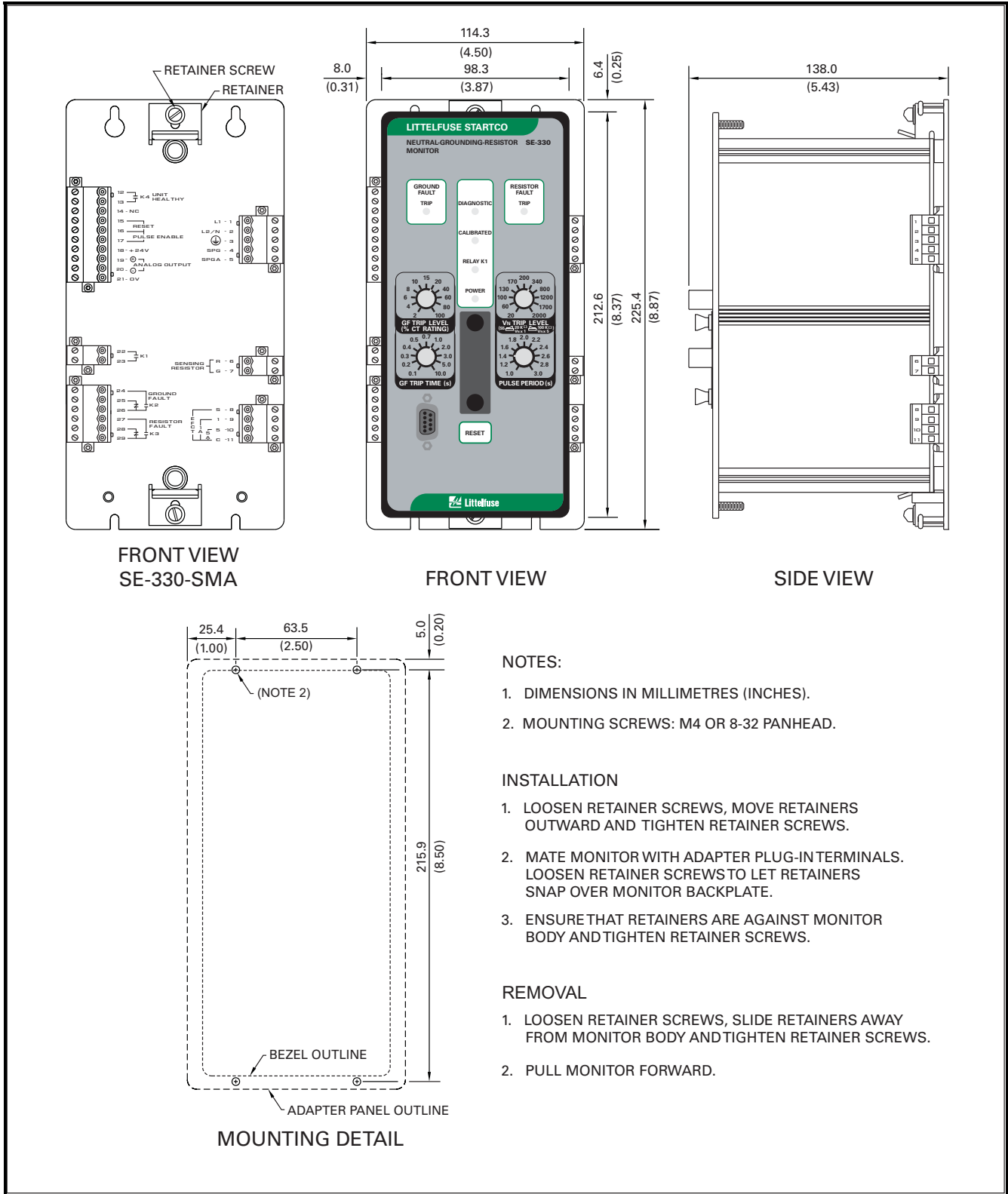

FIGURE 5. SE-330 Outline and Surface-Mounting Details.

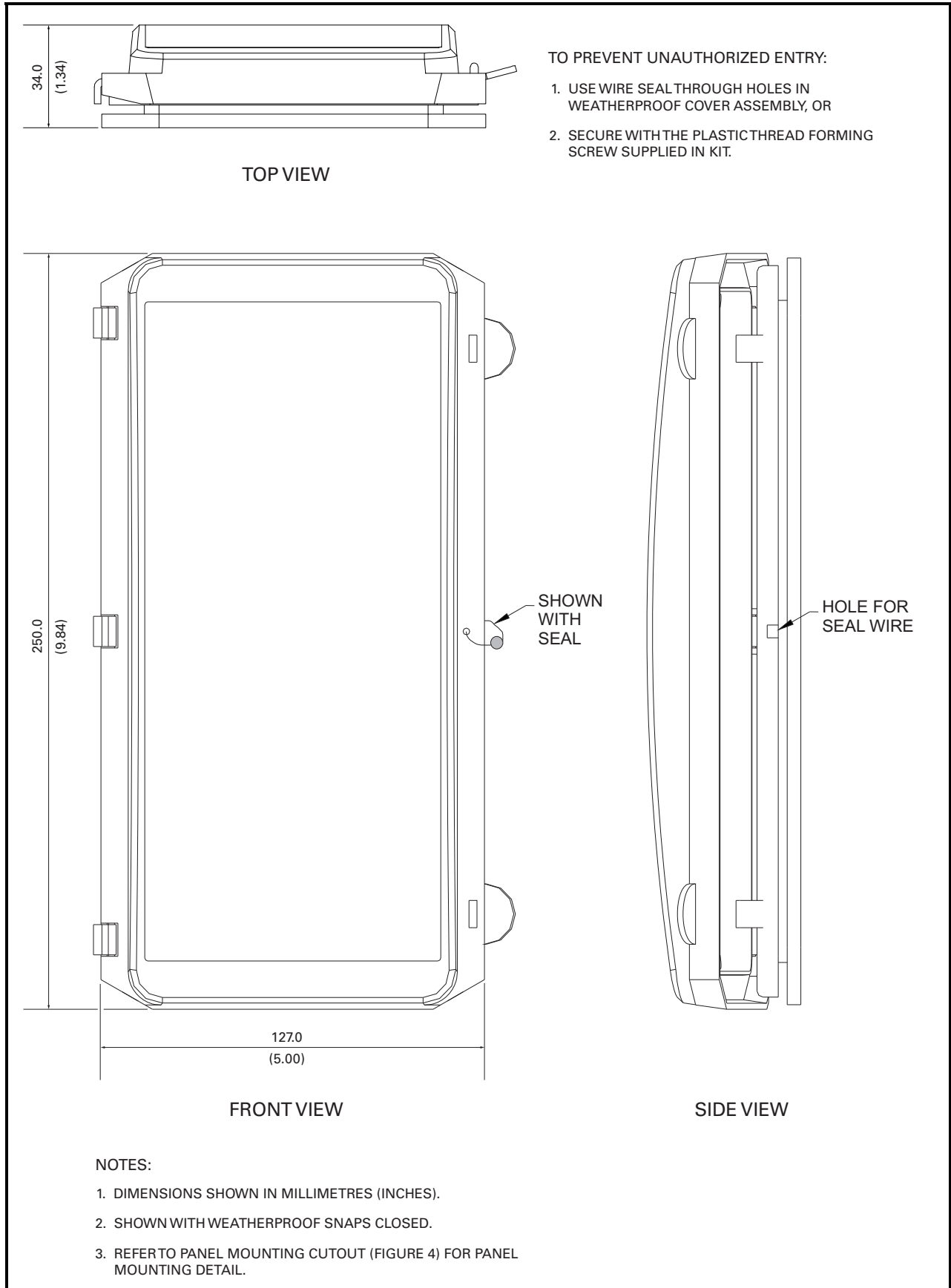

FIGURE 6. SE-IP65CVR-G Weatherproof Cover Outline

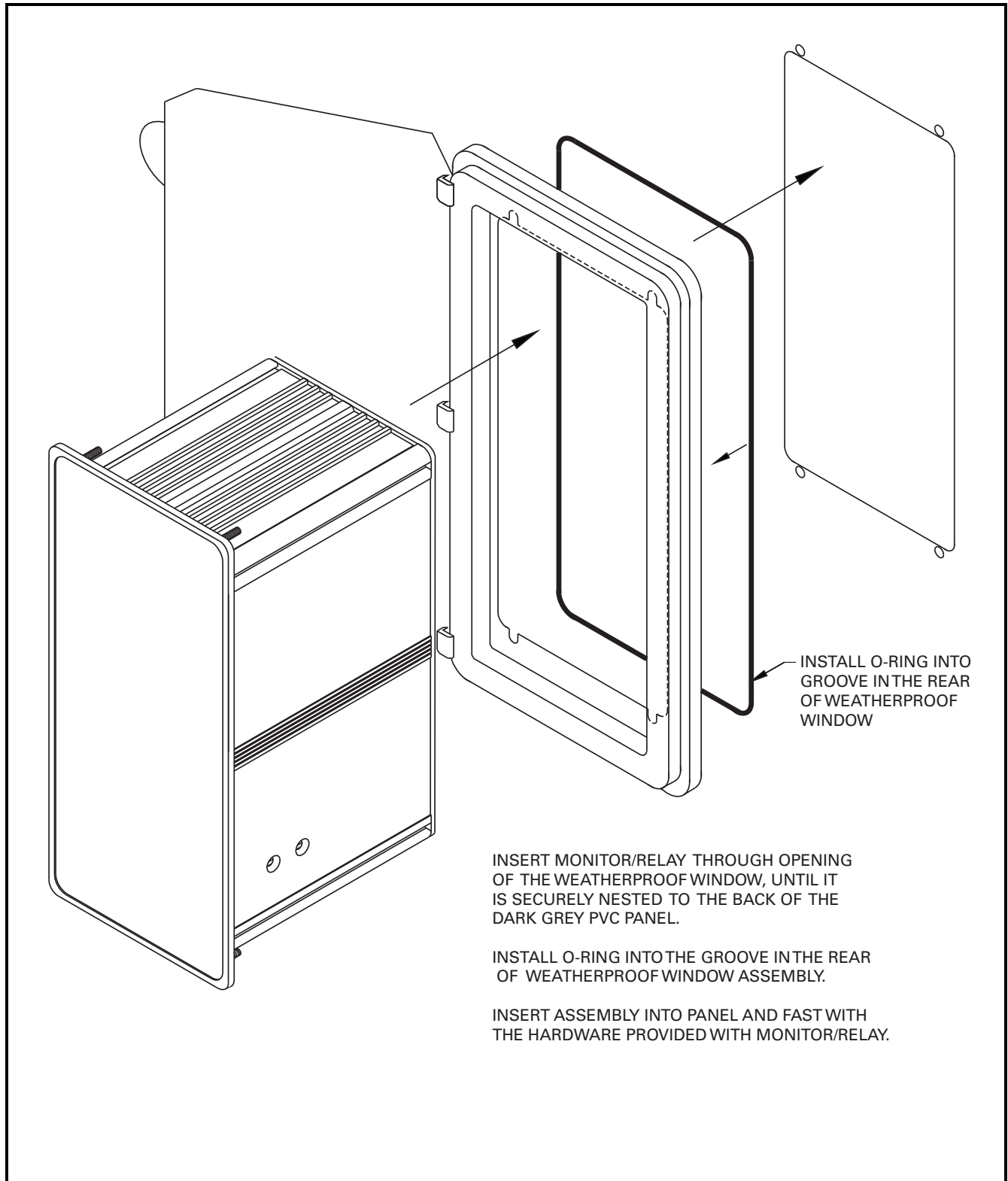

FIGURE 7. SE-IP65CVR-G Weatherproof Cover Installation

3.2 SENSING RESISTOR

Outline and mounting details for ER-600VC, ER-5KV, ER-5WP, ER-15KV, ER-25KV, and ER-35KV sensing resistors are shown in Figs.8, 11, 12, 13, 14, and 15. Locate the NGR and the sensing resistor near the transformer or generator. When located outdoors, a sensing resistor must be installed in a suitable enclosure. An optional SE-MRE-600 Moisture-Resistant Enclosure is available for applications which may expose an ER-600VC to moisture. See Figs. 9 and 10. The weather-protected ER-5WP shown in Fig. 12 is an ER-5KV with moisture-resistant terminal covers. Use an ER-5WP in applications in which it might be exposed to moisture. The ER-15KV, ER-25KV, and ER-35KV include moisture-resistant terminal covers. Use suitable water-tight fittings. Ground sensing-resistor terminal G. Pass the sensing-resistor-to-neutral conductor and the NGR-to-neutral conductor through the ground-fault-CT window as shown in Fig. 3. Separately connect sensing-resistor terminal N and the NGR to the neutral to include neutral connections in the monitored loop. Alternately, if the NGR connection to system neutral need not be monitored, connect terminal N to the NGR neutral terminal.

If a ground fault in the sensing-resistor conductor is unlikely, a minimal loss of protection will result if it does not pass through the ground-fault-CT window. See Note 3 in Fig. 3.

CAUTION: Voltage at terminal N rises to line-to-neutral voltage when a ground fault occurs. The same clearances are required for sensing resistors as for NGR's.

NOTE: A parallel ground path created by moisture can result in a false resistor-fault trip. Sensing-resistor terminal R and its connection to SE-330 terminal R, including interposing terminal blocks, must remain dry.

NOTE: The neutral-to-sensing-resistor-terminal-N connection is not a neutral conductor as defined in Canadian Electrical Code Section 10-1108 and National Electrical Code Section 250.36(B). It is not required to be 8 AWG or larger. Since current through this conductor is always less than 250 mA, a 14 AWG conductor insulated to the system voltage is more than sufficient.

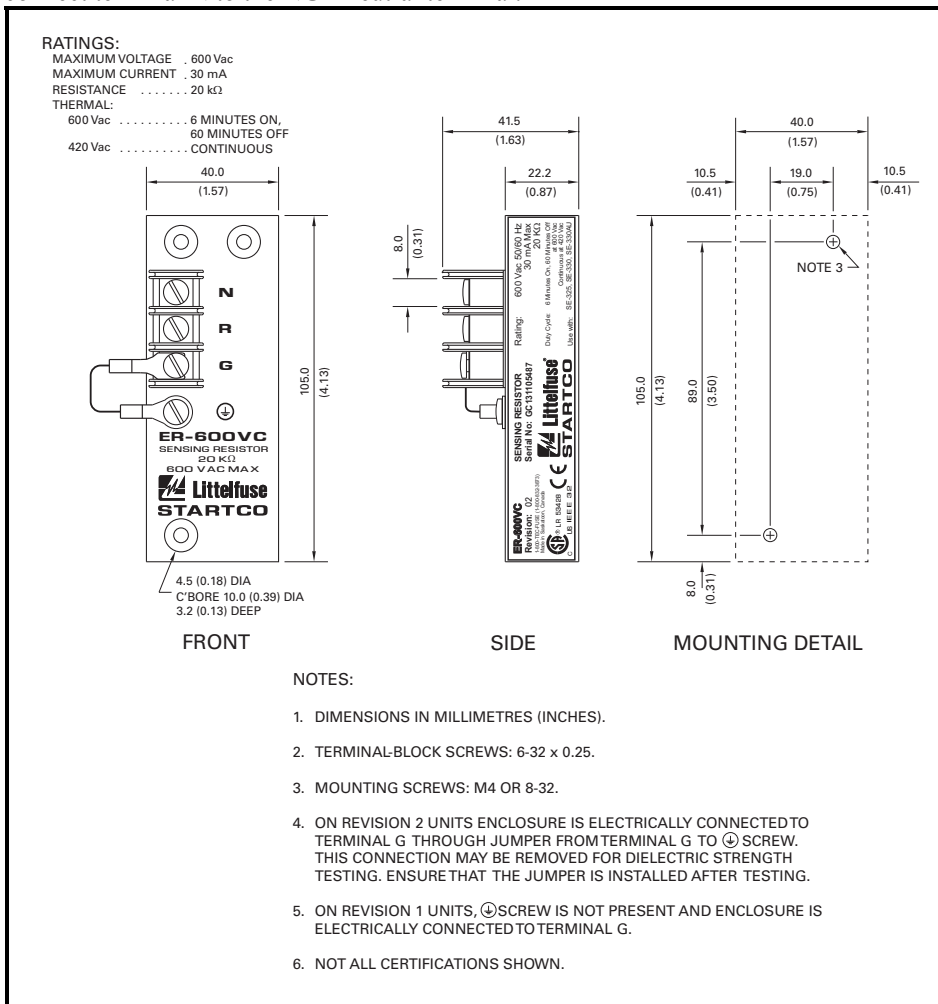

FIGURE 8. ER-600VC Sensing Resistor.

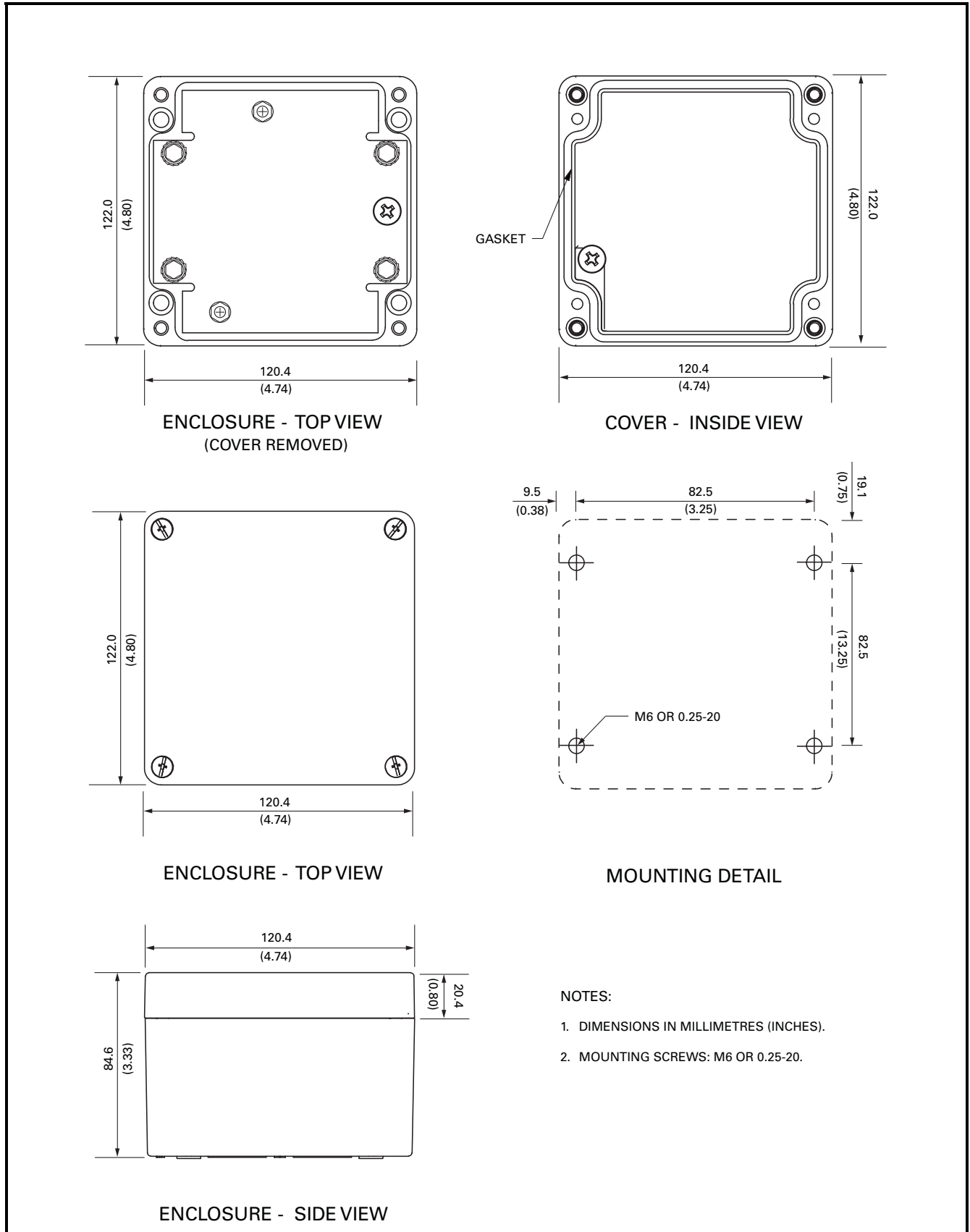

FIGURE 9. SE-MRE-600 Moisture-Resistant Enclosure Outline.

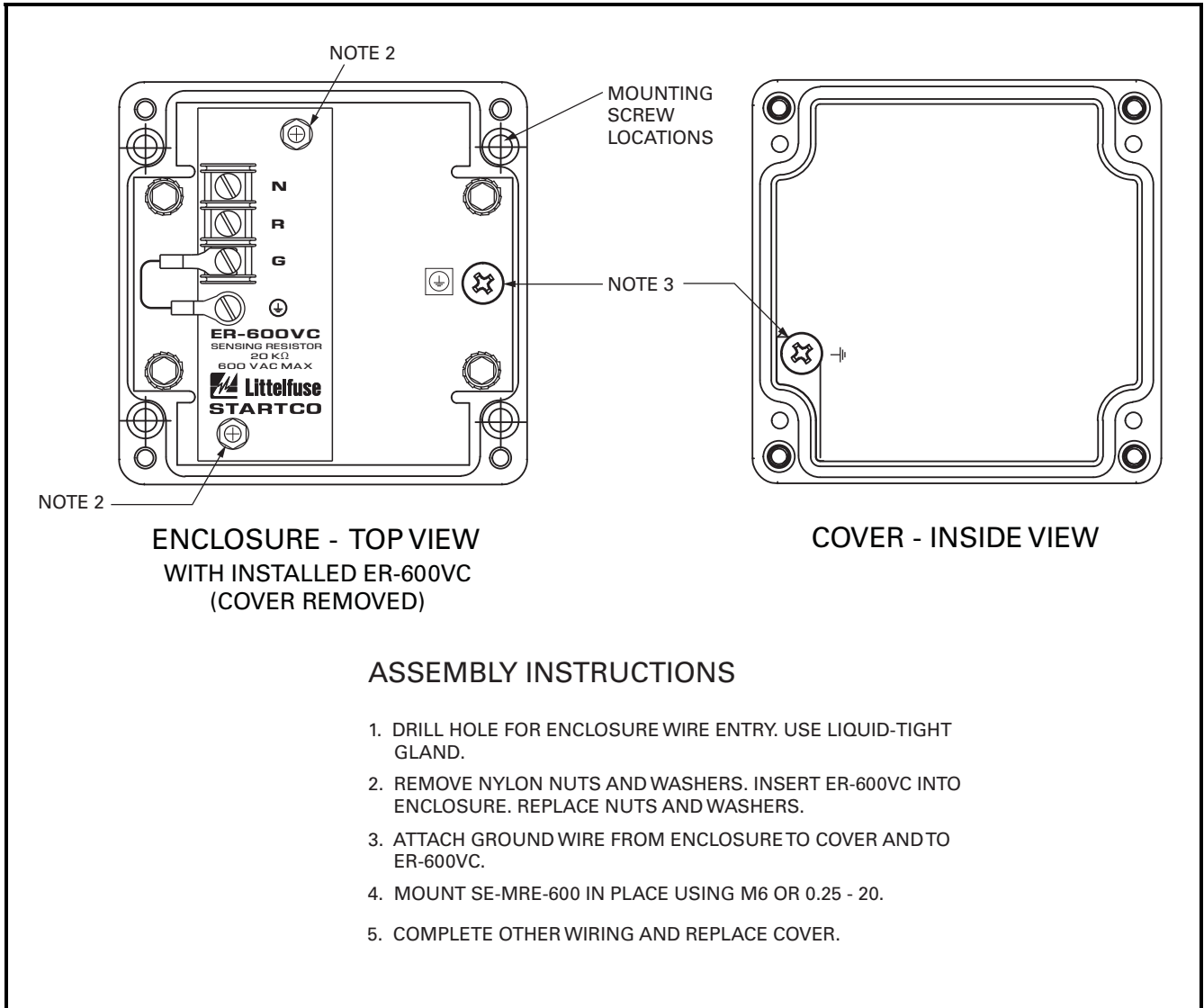
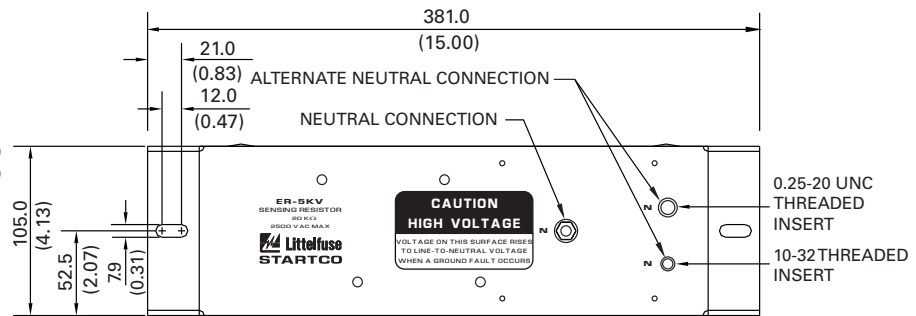

FIGURE 10. SE-MRE-600 with installed ER-600VC.

RATINGS:

MAXIMUM VOLTAGE . . . 2,500 Vac
 MAXIMUM CURRENT. 125 mA
 RESISTANCE 20 kΩ
 THERMAL CONTINUOUS
TORQUE
 TERMINAL N (3 LOCATIONS)
 10-32 INSERT. 5.6 N-m (50 in-lb)
 OTHERS. 9.0 N-m (80 in-lb)



TOP VIEW

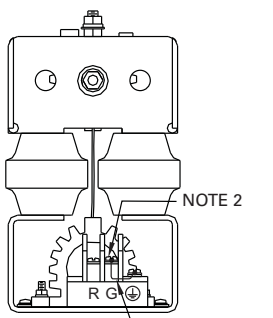

SIDE VIEW

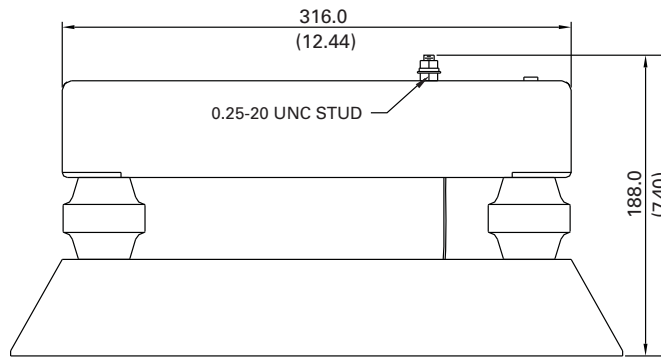

FRONT VIEW

NOTES:

1. DIMENSIONS IN MILLIMETRES (INCHES).
2. TERMINAL-BLOCK SCREWS: 6-32 x 0.25.
3. MOUNTING SCREWS: M6 OR 0.25-20.
4. THIS DEVICE CAN DISSIPATE 300 WATTS. TO MINIMIZE SURFACE TEMPERATURES FOR SYSTEMS ALLOWED TO OPERATE CONTINUOUSLY WITH A GROUND FAULT, MOUNT VERTICALLY WITH R & G TERMINALS DOWN.
5. ON REVISION 2 UNITS BASE IS ELECTRICALLY CONNECTED TO TERMINAL G THROUGH JUMPER FROM TERMINAL G TO ⊕ SCREW. THIS CONNECTION MAY BE REMOVED FOR DIELECTRIC STRENGTH TESTING. ENSURE THAT THE JUMPER IS INSTALLED AFTER TESTING.
6. ON REVISION 0 & 1 UNITS ⊕ SCREW IS NOT PRESENT AND BASE IS ELECTRICALLY CONNECTED TO TERMINAL G.
7. CERTIFICATIONS NOT SHOWN.

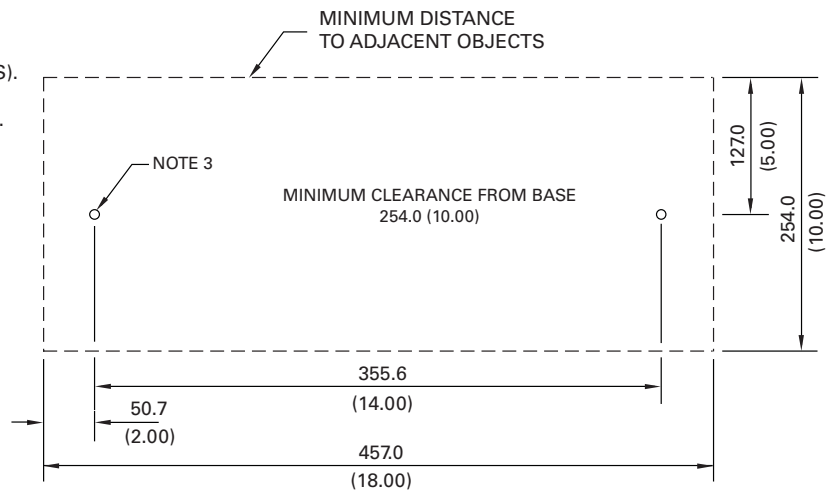

MOUNTING DETAIL

FIGURE 11. ER-5KV Sensing Resistor.

RATINGS:

- MAXIMUM VOLTAGE . . . 2,500 Vac
- MAXIMUM CURRENT. 125 mA
- RESISTANCE 20 kΩ
- THERMAL CONTINUOUS
- TORQUE
- TERMINAL N (3 LOCATIONS)
- 10-32 INSERT 5.6 N-m (50 in-lb)
- OTHERS 9.0 N-m (80 in-lb)

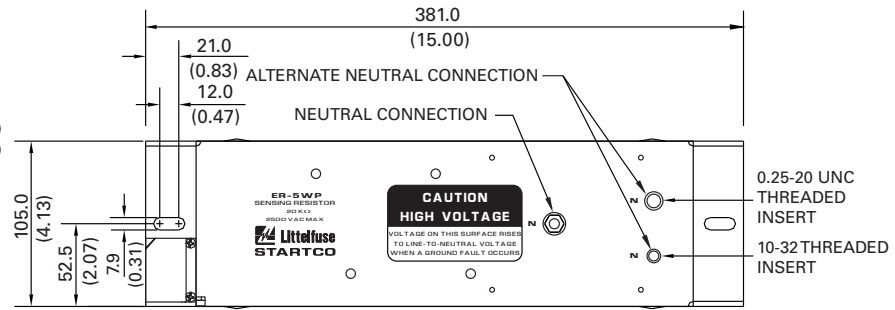

TOP VIEW

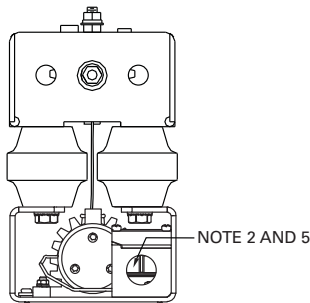

SIDE VIEW

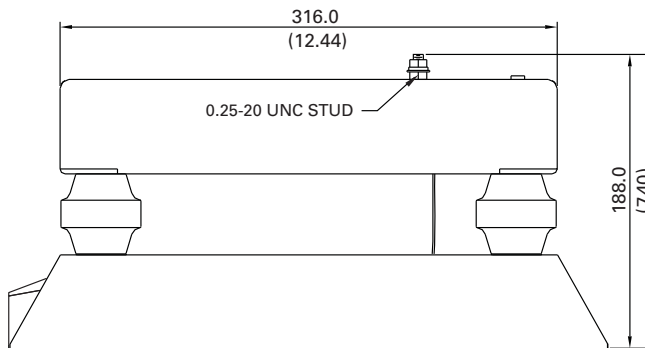

FRONT VIEW

NOTES:

1. DIMENSIONS IN MILLIMETRES (INCHES).
2. TERMINAL-BLOCK SCREWS: 6-32 x 0.25 CABLE ACCESS OPENING IS 1/2 NPT. USE A LIQUID-TIGHT FITTING FOR CABLE ENTRY.
3. MOUNTING SCREWS: M6 OR 0.25-20.
4. THIS DEVICE CAN DISSIPATE 300 WATTS. TO MINIMIZE SURFACE TEMPERATURES FOR SYSTEMS ALLOWED TO OPERATE CONTINUOUSLY WITH A GROUND FAULT, MOUNT VERTICALLY WITH R & G TERMINALS DOWN.
5. BASE IS ELECTRICALLY CONNECTED TO TERMINAL G THROUGH JUMPER FROM TERMINAL G TO Ⓧ SCREW. THIS CONNECTION MAY BE REMOVED FOR DIELECTRIC STRENGTH TESTING. ENSURE THAT THE JUMPER IS INSTALLED AFTER TESTING.
6. CERTIFICATIONS NOT SHOWN.

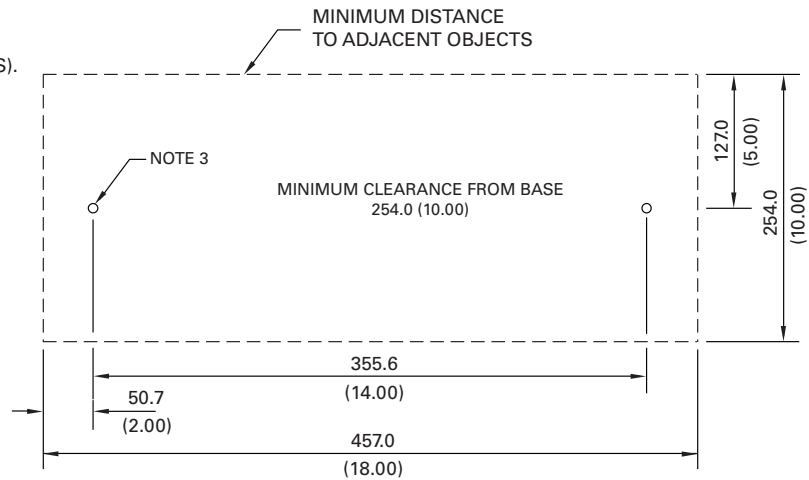

MOUNTING DETAIL

FIGURE 12. ER-5WP Sensing Resistor.

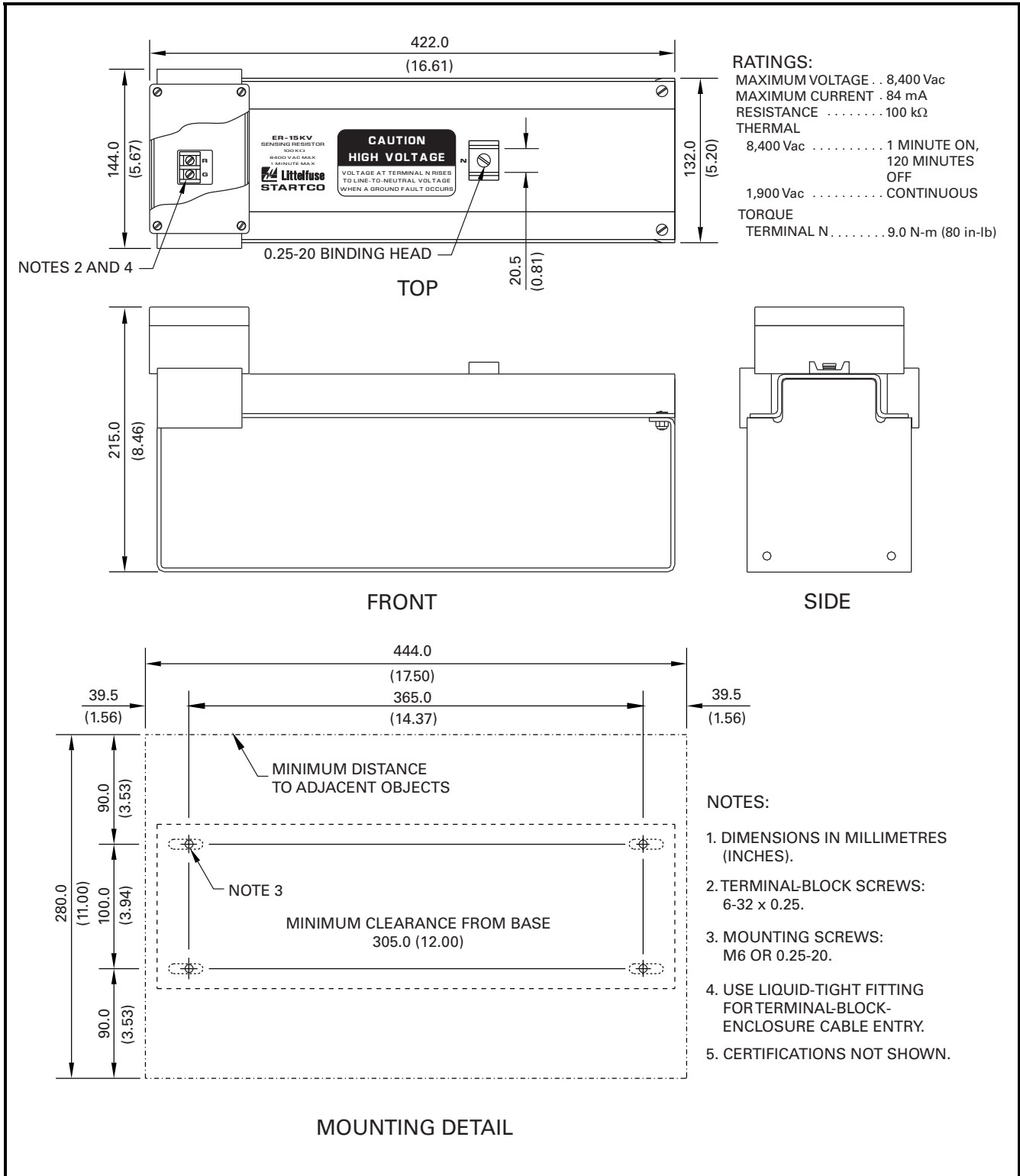

FIGURE 13. ER-15KV Sensing Resistor.

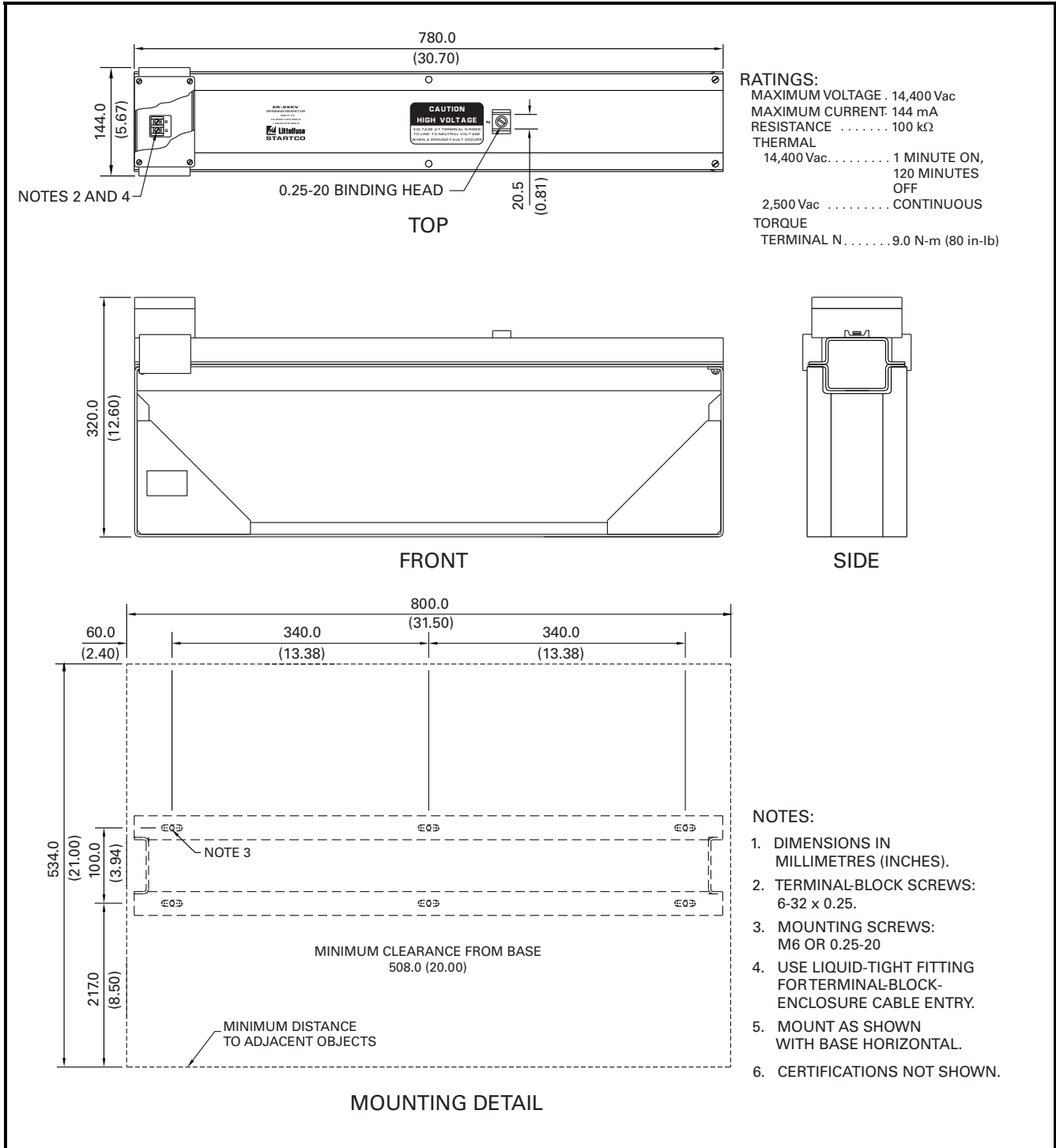

FIGURE 14. ER-25KV Sensing Resistor.

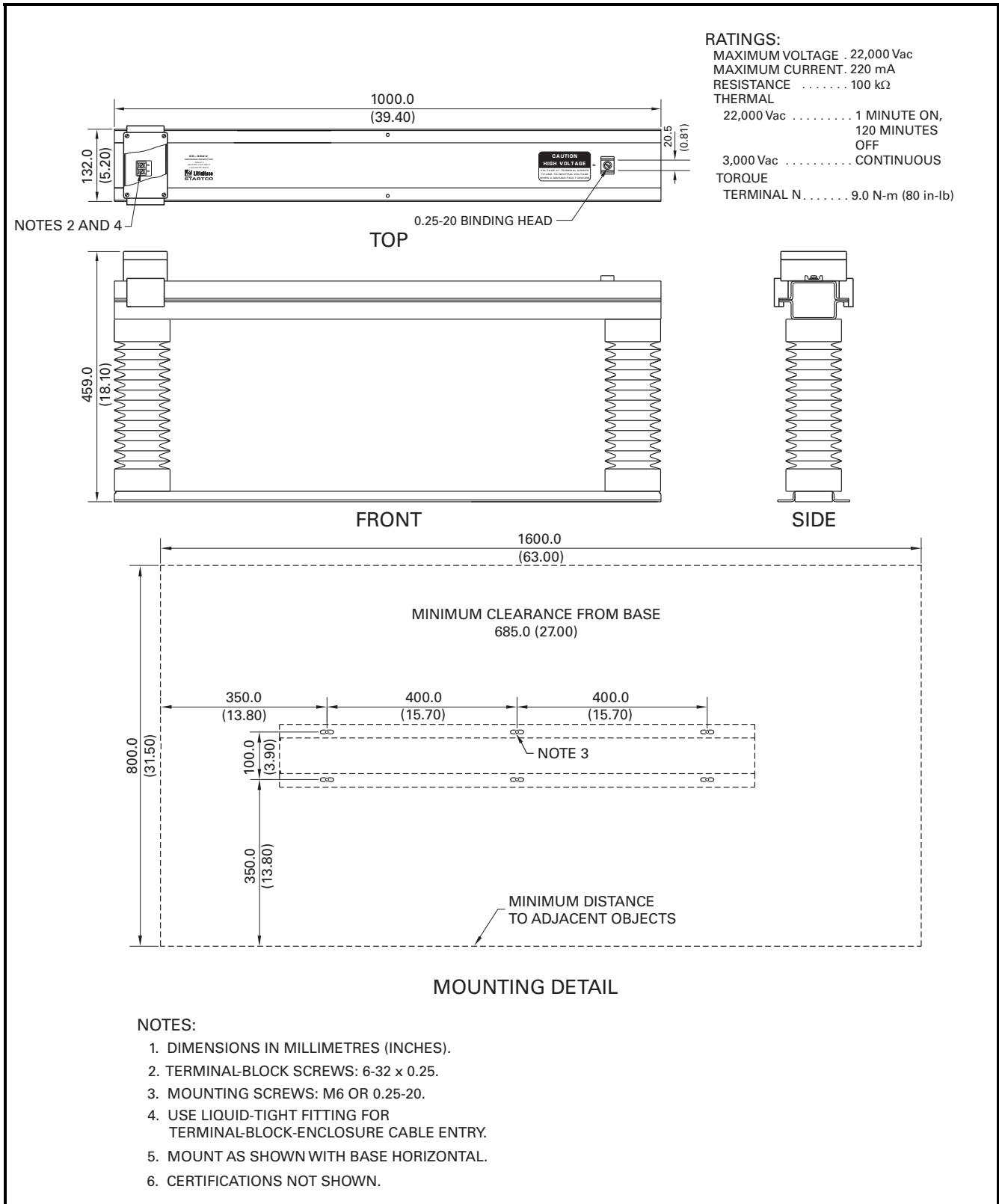

FIGURE 15. ER-35KV Sensing Resistor.

3.3 GROUND-FAULT CT

Select and install a ground-fault CT that will provide the desired trip level. Typically, the CT-primary rating should approximately equal the NGR let-through-current rating. This provides an appropriate GF TRIP LEVEL setting range and analog-output scaling. See Section 2.1.2 and 2.9.

Outline and mounting details for the sensitive EFCT- and SE-CS30-series current sensors are shown in Figs. 16, 17, and 18. Ground-fault-CT connections and the typical ground-fault-CT location are shown in Fig. 3.

For SE-325 replacement applications, the existing CT200 current transformer will typically have to be replaced. However, where replacement is not necessary or possible, the CT200 can be connected to either the 1- or 5-A input. This CT has a 200:5 current ratio. If connected to the 1-A input, the ground-fault trip level will be a percentage of 40 A. See Section 2.1.2.

The accuracy of a typical current transformer, including the CT200, decreases below 5% of its current rating. CT-primary current injection testing is recommended to verify trip levels below 5% of the CT-primary rating. See Section 9.4. Littelfuse Startco sensitive current sensors are designed for use at low levels and respond linearly to 2% current rating.

<p>NOTE: The current-transformer insulation class is of no consequence if its secondary is grounded and the conductors through its window are insulated for the system voltage. Medium-voltage systems may require a bushing-type CT.</p>
--

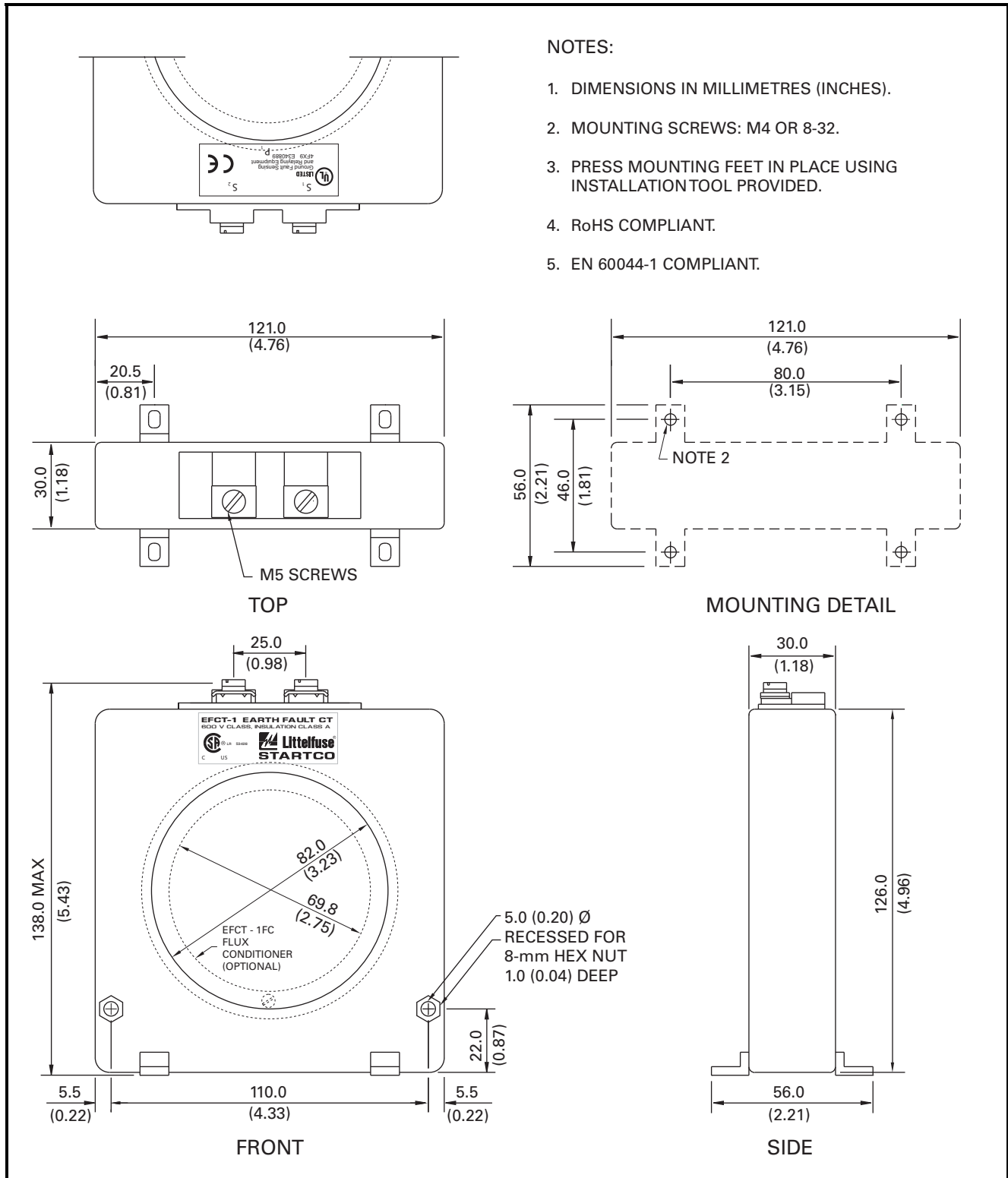

FIGURE 16. EFCT-1 Ground-Fault Current Sensor.

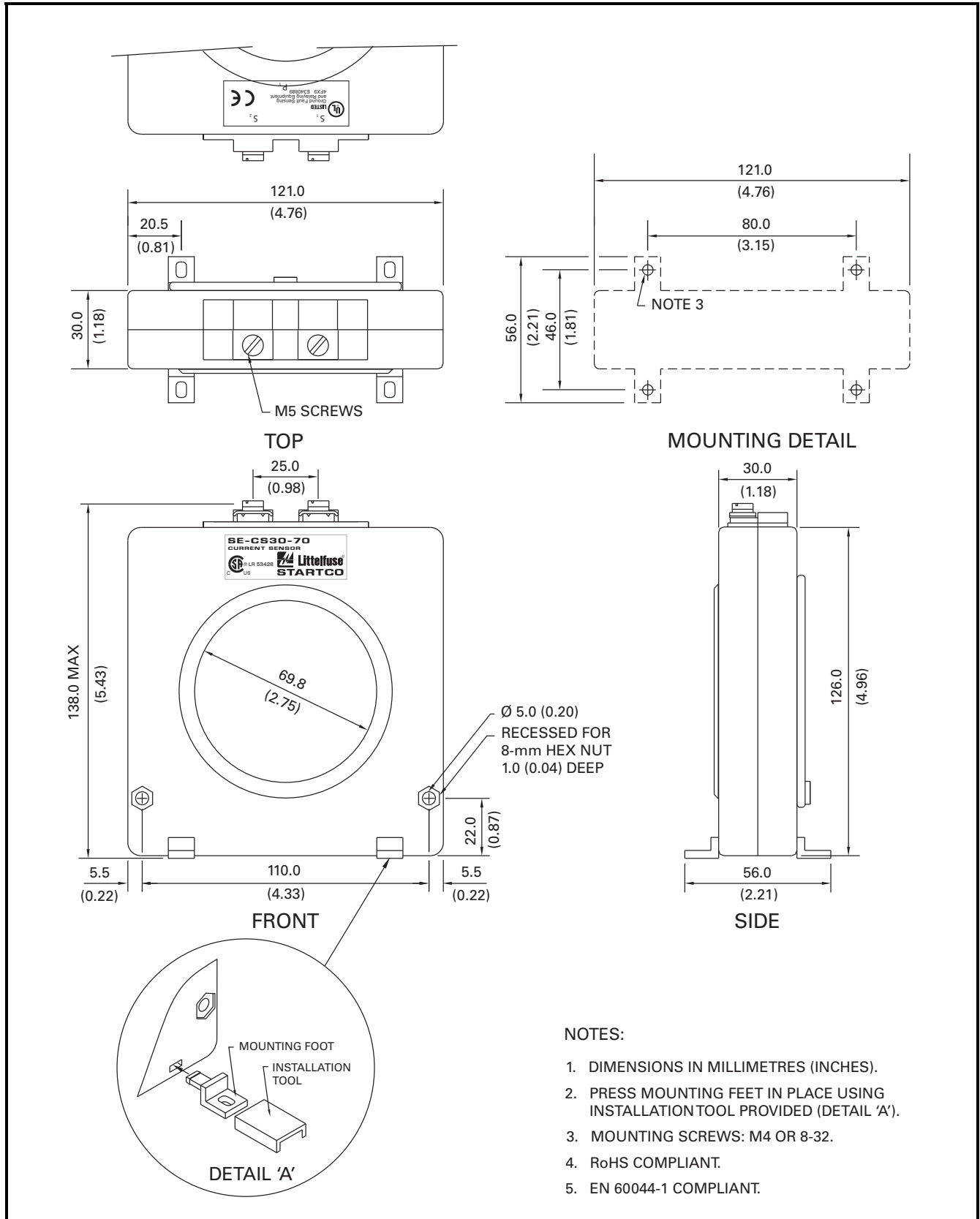

FIGURE 17. SE-CS30-70 Ground-Fault Current Sensor.

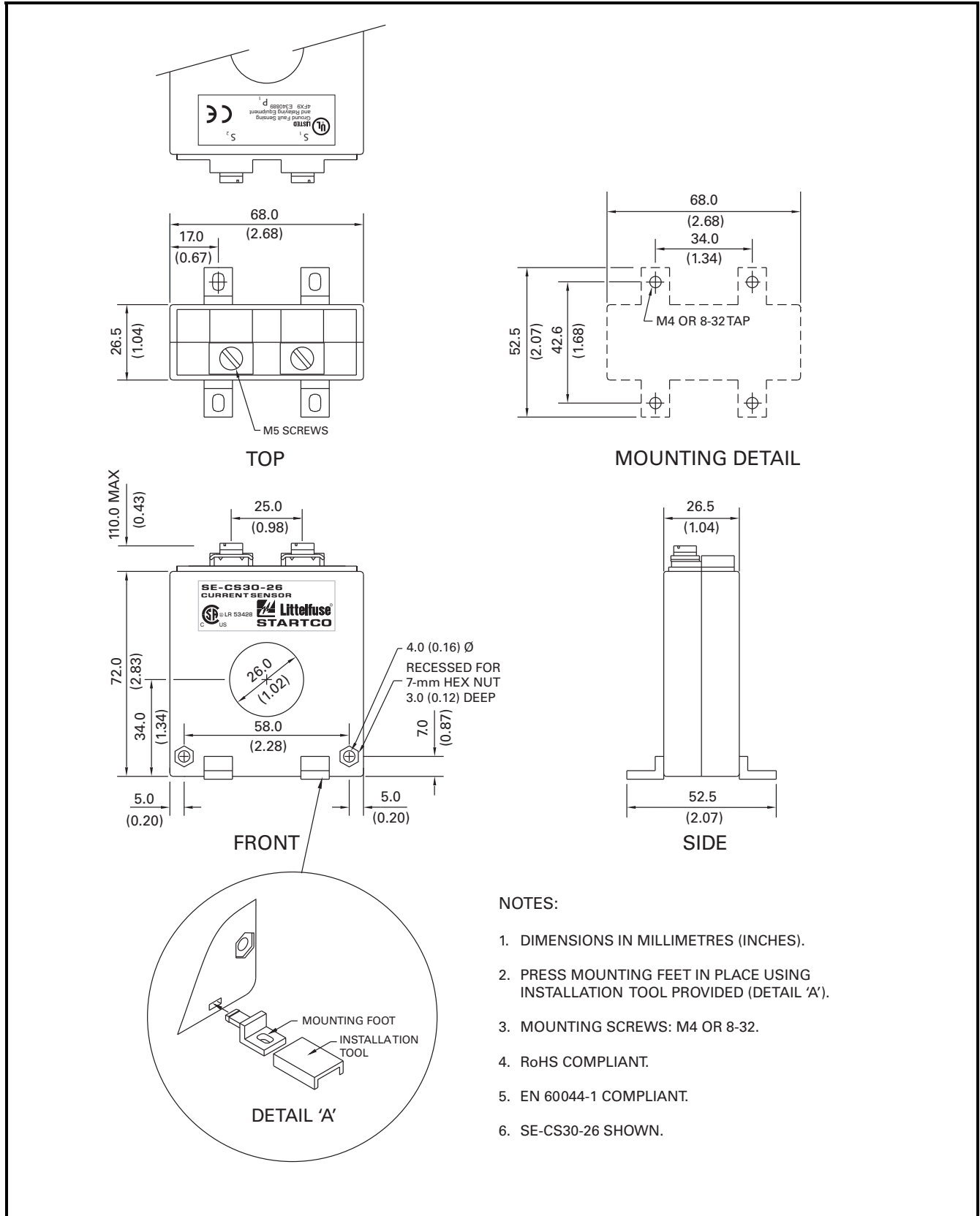

FIGURE 18. EFCT-26 and SE-CS30-26 Ground-Fault Current Sensors.

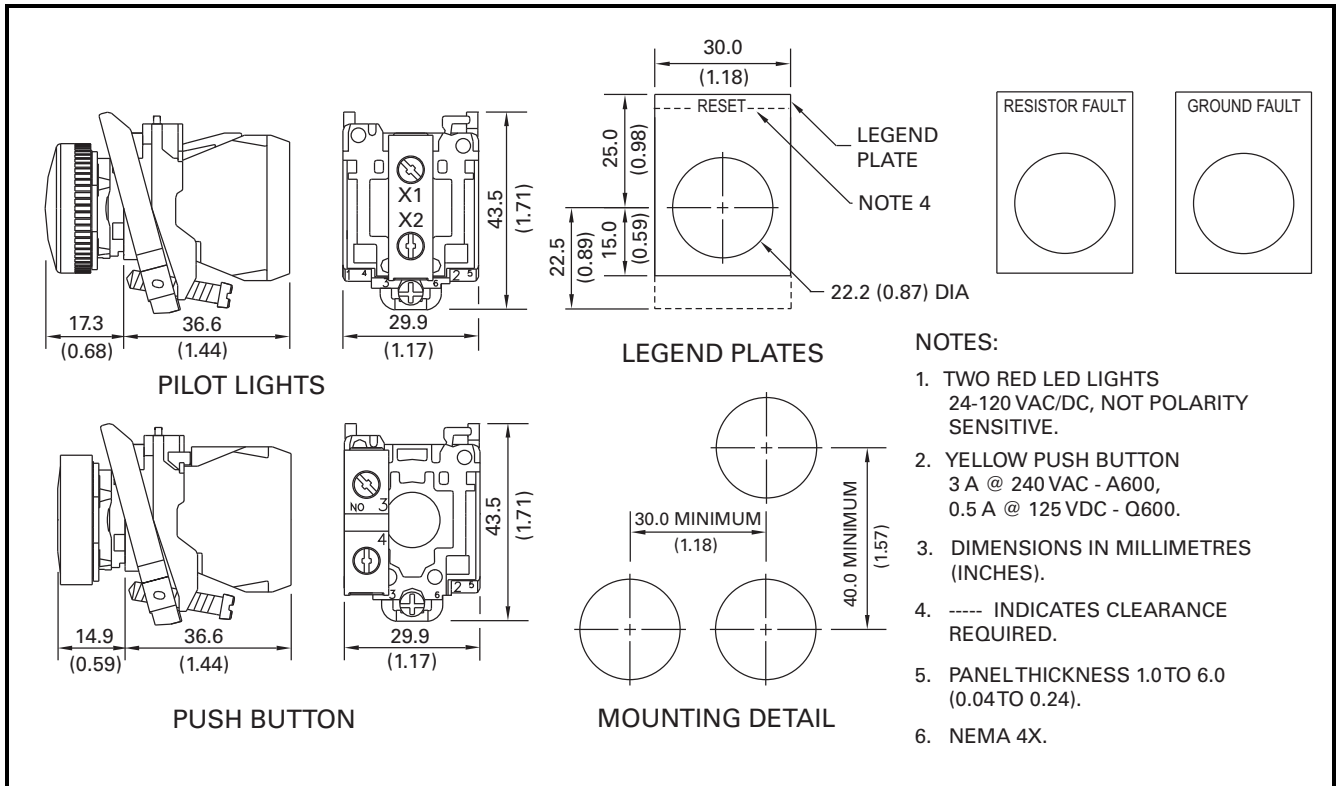

FIGURE 19. RK-332 Remote Indication and Reset.

3.4 ISOLATED GROUND CONNECTION

An isolated ground bed can prevent a ground potential rise (GPR) from being transferred to remote equipment. If the G terminals on the sensing resistor and the SE-330 are connected to an isolated ground, the SE-330 will be exposed to the GPR. If the GPR is greater than the terminal-block rating, the SE-330 must be isolated from station ground and precautions must be taken with the power supply and the trip contacts. See Technical Note RG-1 “NGR Monitoring with Isolated Ground Beds” at www.littelfuse.com/protectionrelays.

A configuration which allows an SE-330 to be connected to station ground is shown in Fig. 20. The SE-330 monitors the series combination of the NGR and the two ground beds. This configuration is acceptable provided the series resistance of the NGR and the ground beds is within the NGR calibration range and ground-bed-resistance changes remain within the trip range. See Section 6.1.

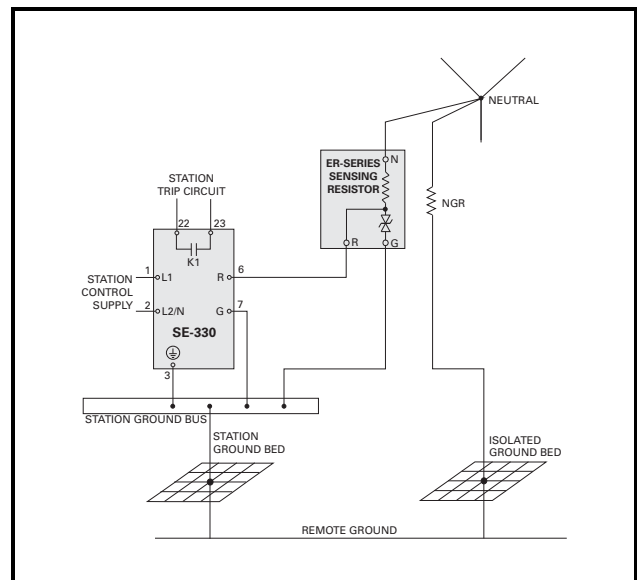

FIGURE 20. Simplified Isolated-Ground Connection.

3.5 PULSING CONNECTION

Set switch S1 to K1 = PULSING and use an external switch as shown in Fig. 21 to use relay K1 to control a pulsing contactor. Relays K2 and K3 can be used for tripping; however, they operate in the non-fail-safe mode only.

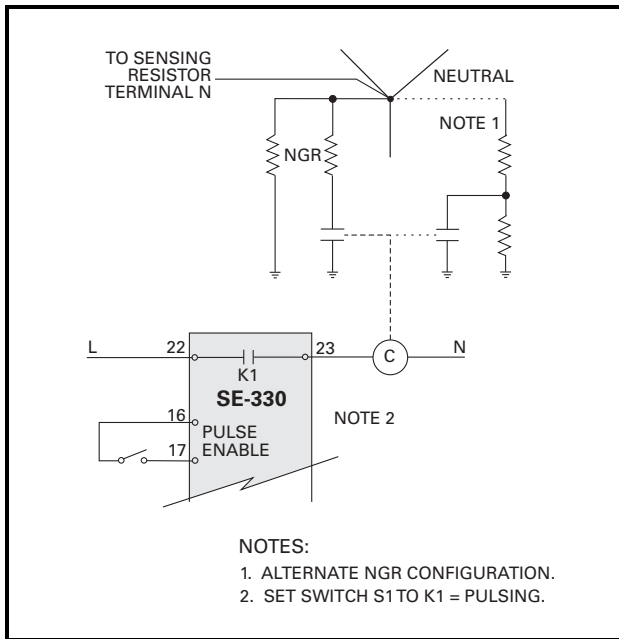

FIGURE 21. Simplified Pulsing Connection.

4. COMMUNICATIONS

4.1 LOCAL COMMUNICATIONS PORT

The SE-330 has an RS-232 communications port which is designed for use with firmware-upgrade and system-monitoring software running on a PC.

The RS-232 port is non-isolated and operates as a DCE device with the connector (socket contacts) pin-out listed in Table 3. This port allows direct connection to a PC using standard DB-9 connector cables. Cable length should not exceed 10 metres.

TABLE 3. RS-232 DB-9 TERMINALS

PIN #	SIGNAL NAME	COMMENTS
1	DCD	470 Ω connected to +12 V
2	RD	Output to DTE from SE-330
3	TD	Input from DTE to SE-330
4	DTR	Not connected
5	SG	Signal Ground
6	DSR	470 Ω connected to +12 V
7	RTS	Not connected
8	CTS	470 Ω connected to +12 V
9	RI	Not connected

4.1.1 LOCAL DATA ACQUISITION

The SE-330 outputs a data packet every second. Data output is in the standard UART data format of eight data bits and one stop bit. The baud rate is fixed at 38,400 bits per second. Use PC program SE-MON330 to display the following data:

- SE-330 settings and switch states.
- Neutral voltage and current.
- Resistance change.
- Trip status.
- Pending trips.
- Relay and LED status.
- NGR calibration value.
 - Expected 20-kΩ value: R_{NGR} to $(R_{NGR}-300)$
 - Expected 100-kΩ value: R_{NGR} to $(R_{NGR}-4,000)$
- Firmware revision level.
- The last ten trip records. Each record contains the trip cause and the pre-trip NGR current, voltage, and resistance values.

Data can be logged to a PC file at user-defined time intervals for future analysis.

4.1.2 LOCAL COMMUNICATIONS COMMANDS

As of firmware revision 10, the SE-330 supports event record commands through the local RS-232 communications port. Commands are input as standard ASCII characters. The latest revision of SE-MON330 supports the following commands:

- 'd' – Read event records.
- 'c' – Clear event records

4.1.3 FIRMWARE UPGRADE

The local port can be used to upgrade the SE-330 firmware. Upgrade procedure:

- 1) Remove supply voltage.
- 2) Set switch S8 to UPGRADE.
- 3) Apply supply voltage. The DIAGNOSTIC LED will be on and all relays will be de-energized.
- 4) Run SE-FLASH and follow the instructions.
- 5) Remove supply voltage.
- 6) Set switch S8 to RUN.
- 7) Apply supply voltage.

SE-MON330 and SE-FLASH are available at www.littelfuse.com/protectionrelays.

4.2 NETWORK COMMUNICATIONS

The SE-330 interface for optional communications modules supports DeviceNet™, PROFIBUS®, and Ethernet:

DeviceNet™:

- DeviceNet Slave.
- DeviceNet specification Vol 1:2.0, Vol 2:2.0.

PROFIBUS®:

- PROFIBUS-DP Slave according to IEC 61158.

Ethernet:

- Modbus TCP Class 0, 1.
- Ethernet/IP Level 2 I/O Server CIP (ControlNet and DeviceNet)
- WebServer, on-board selection of IP address.

Communications options allow the user to:

- Read SE-330 settings.
- Read neutral voltage and current.

- Read resistance change.
- Read trip status.
- Reset trips.
- Perform a remote trip.
- Access the last ten trip records. Each trip record contains the cause of trip and the pre-trip NGR current, voltage, and resistance values.
- Clear event records.

Refer to the appropriate SE-330 communications-interface manual.

5. TROUBLESHOOTING

PROBLEM	SOLUTION
POWER LED off.	Check if supply voltage is present on terminals 1 and 2. If present, an overvoltage may have caused the power supply to shutdown. Cycle supply voltage. If POWER LED remains off, return unit for repair.
POWER LED flashes.	A power-supply overload has occurred. Cycle supply voltage. If problem persists, consult Littelfuse Startco.
Calibration-Error Trip DIAGNOSTIC LED flash code = L-S-L...*	The total resistance of the NGR and sensing-resistor circuit is outside the calibration range. Verify that switch S5 is set to match the resistance of the sensing resistor, check the resistance of the NGR, and verify the sensing-resistor circuit. See Section 9.2 for sensing-resistor tests. Repeat the calibration procedure after the open or shorted condition has been corrected.
Remote Trip DIAGNOSTIC LED flash code = L-S-S-L...*	The SE-330 was tripped by a signal from network communications. Press RESET to clear the trip.
EEPROM-Error Trip DIAGNOSTIC LED flash code = L-S-S-S-L...*	An error was detected in the EEPROM. Press RESET to clear the trip. If the problem persists, consult Littelfuse Startco.
A/D-Converter-Error Trip DIAGNOSTIC LED flash code = L-S-S-S-L...*	An A/D-converter error was detected. Press RESET to clear the trip. If the problem persists, consult Littelfuse Startco.
Software-Interrupt Trip DIAGNOSTIC LED flash code = L-S-S-S-S-L...*	These four errors result in a processor reset. During reset, UNIT HEALTHY relay K4 will be de-energized. After a reset, UNIT HEALTHY relay K4 will be energized. Press RESET to clear the trip. If the problem persists, consult Littelfuse Startco.
Illegal-Opcode Trip DIAGNOSTIC LED flash code = L-S-S-S-S-S-L...*	When supply voltage is cycled, the specific error code is lost but the CPU Trip Code will be displayed.
Watchdog Trip DIAGNOSTIC LED flash code = L-S-S-S-S-S-S-L...*	
Clock-Failure Trip DIAGNOSTIC LED flash code = L-S-S-S-S-S-S-S-L...*	
CPU Trip DIAGNOSTIC LED flash code = L-S-S-S-S-S-S-S-S-L...*	This code is displayed if the supply is cycled after one of the previous four errors occurred. Press RESET to clear the trip.
DIAGNOSTIC LED = Solid Red	Switch S8 is in the UPGRADE position. If firmware upgrade is not required, set switch S8 to RUN and cycle supply. SE-330 processor failed to start. Cycle supply. Consult Littelfuse Startco if problem persists.
Pressing RESET does not clear trips.	Trip condition is still present. Locate and correct. The face-plate RESET button is disabled if remote-reset terminals 15 and 16 are connected. Replace shorted remote-reset switch or issue Reset command from the communications network.
UNIT HEALTHY relay K4 momentarily changes state.	Occurs when processor is reset.
GROUND-FAULT and RESISTOR-FAULT LED's flash during reset.	Normal operation.
No analog-output current.	The output at terminals 19 and 20 requires a voltage source. See Fig. 2 for analog-output connections. See Section 9.3 for the analog-output tests.

*L = long pause, S = short flash.

6. TECHNICAL SPECIFICATIONS

6.1 SE-330

Supply

Option 0.....	30 VA, 120 to 240 Vac (+10, -45%) 50/60 Hz; 20 W, 110 to 250 Vdc (+10, -25%)
Option 2.....	20 W, 48 Vdc (+50, -25%) 35 VA, 48 Vac (+10, -45%) 50/60 Hz

Power-Up Time 250 ms at 120 Vac

AC Measurements Discrete Fourier Transform. 16 samples per cycle, 50 or 60 Hz

Resistor-Fault Circuit:

Neutral-To-Ground Voltage Trip Levels:

ER-600VC or ER-5KV	20; 60; 100; 130; 170; 200; 340; 800; 1,200; 1,700; 2,000 Vac
ER-15KV to ER-35KV	100; 300; 500; 650; 850; 1,000; 1,700; 4,000; 6,000; 8,500; 10,000 Vac

Accuracy 5% of setting

3 dB Frequency Response ..

S6 = 50 Hz.....	25-85 Hz
S6 = 60 Hz.....	30-90 Hz

NGR Calibration Range:

ER-600VC or ER-5KV	0 to 2 k Ω
ER-15KV to ER-35KV	0 to 10 k Ω

Trip Resistance, $V_N = 0$:

ER-600VC or ER-5KV	500- Ω change \pm 200 Ω
ER-15KV to ER-35KV	2.5-k Ω change \pm 1 k Ω

Neutral-To-Ground DC-Voltage Rejection:

ER-600VC or ER-5KV	25 Vdc
ER-15KV to ER-35KV	125 Vdc

Trip Time..... 12 \pm 1 s

Trip Hold-Off Level..... 5% of CT-Primary Rating

Operating Mode Latching/Non-Latching

Ground-Fault Circuit:

Trip Level.....	2, 4, 6, 8, 10, 15, 20, 40, 60, 80, 100% of CT-Primary Rating
Trip Time.....	0.1, 0.2, 0.3, 0.4, 0.5, 0.7, 1.0, 2.0, 3.0, 5.0, 10.0 s
Trip-Level Accuracy.....	1% of CT-Primary Rating
Trip-Time Accuracy	10% of Setting

3 dB Frequency Response

S6 = 50 Hz.....	25-85 Hz
S6 = 60 Hz.....	30-90 Hz

Maximum CT lead resistance:

EFCT & SE-CS30	5 Ω
Other CT's.....	Consult CT Curve.

CT-Input Burden:

5-A Input	< 0.01 Ω
-----------------	-----------------

1-A Input.....	< 0.05 Ω
EFCT Input.....	< 10 Ω

Thermal Withstand:

1-A and 5-A Input:	
Continuous	2 x CT Rating
1-Second.....	20 x CT Rating

EFCT Input:

Continuous	10 x CT Rating
1-Second.....	25 x CT Rating
Measurement Range	25 x CT-Primary Rating
Operating Mode	Latching/Non-Latching

Pulsing Circuit:

Pulse Period.....	1.0 to 3.0 s, 0.2-s increments
Duty Cycle	50%
Time Accuracy.....	10% of Setting

Trip/Pulsing Relay K1 Contacts:

Configuration	N.O. (Form A)
Operating Mode	Fail-Safe or Non-Fail-Safe
CSA/UL Contact Ratings	8 A resistive 250 Vac, 5 A resistive 30 Vdc

Supplemental Contact Ratings:

Make/Carry 0.2 s	30 A
Break:	
dc	75 W resistive, 35 W inductive (L/R = 0.04)
ac	2,000 VA resistive, 1,500 VA inductive (PF = 0.4)

Subject to maximums of 8 A and 250 V (ac or dc).

GF (K2) and RF (K3) Relay Contacts:

Configuration	N.O. and N.C. (Form C)
Operating Mode	Non-Fail-Safe
CSA/UL Contact Ratings	8 A resistive 250 Vac, 8 A resistive 30 Vdc

Supplemental Contact Ratings:

Make/Carry 0.2s	20 A
Break:	
dc	50 W resistive, 25 W inductive (L/R = 0.04)
ac	2,000 VA resistive, 1,500 VA inductive (PF = 0.4)

Subject to maximums of 8 A and 250 V (ac or dc).

Unit Healthy Output K4 (Option 0):

Configuration	N.O. (Form A)
Operating Mode	Closed when Healthy
Ratings.....	100 mA, 250 V (ac or dc)
Closed Resistance	30 to 50 Ω

Unit Healthy Output K4 (Option 1):

Configuration	N.C. (Form B)
Operating Mode	Open when Healthy
Ratings.....	100 mA, 250 V (ac or dc)
Closed Resistance	25 to 50 Ω

Auto-reset time	2.8 s maximum
4–20-mA Analog Output:	
Type	Self Powered and Loop Powered
Range	4 to 22 mA
Loop Voltage	8 to 36 Vdc
Load	500 Ω (maximum with 24-Vdc supply)
Isolation	120 Vac
Parameter	NGR Current
RS-232 Communications:	
Baud Rate	38.4 kbit/s
Protocol	Proprietary
Terminal-Block Ratings	10 A, 300 Vac, 12 AWG (2.5 mm ²)
PWB Conformal Coating	MIL-1-46058 qualified, UL QMJU2 recognized
Mounting Configurations	Panel Mount and Surface Mount
Shipping Weight	2.0 kg (4.4 lb)
Environment:	
Operating Temperature	-40 to 60°C
Storage Temperature	-55 to 80°C
Humidity	85% Non-Condensing
Surge Withstand	ANSI/IEEE C37.90.1- 1989 (Oscillatory and Fast Transient)
EMC	EN 55011:1998
Certification	CSA, Canada and USA



UL Listed



Australia⁽¹⁾



CE, European Union⁽¹⁾



⁽¹⁾ See Ordering Information.

6.2 SENSING RESISTORS

ER-600VC:	
Maximum Voltage	600 Vac
Maximum Current	30 mA
Resistance	20 kΩ
Thermal	Continuous
Shipping Weight	300 g (0.7 lb)
ER-5KV:	
Maximum Voltage	2,500 Vac
Maximum Current	125 mA
Resistance	20 kΩ
Thermal	Continuous
Shipping Weight	5.0 kg (11 lb)
ER-5WP:	
Maximum Voltage	2,500 Vac
Maximum Current	125 mA
Resistance	20 kΩ
Thermal	Continuous
Shipping Weight	5.0 kg (11 lb)
ER-15KV:	
Maximum Voltage	8,400 Vac
Maximum Current	84 mA
Resistance	100 kΩ
Thermal	1 minute on, 120 minutes off
Shipping Weight	5.0 kg (11 lb)
ER-25KV:	
Maximum Voltage	14,400 Vac
Maximum Current	144 mA
Resistance	100 kΩ
Thermal	1 minute on, 120 minutes off
Shipping Weight	20 kg (44 lb)
ER-35KV:	
Maximum Voltage	22,000 Vac
Maximum Current	220 mA
Resistance	100 kΩ
Thermal	1 minute on, 120 minutes off
Shipping Weight	40 kg (88 lb)

Certification



UL Listed



CE, European Union



6.3 CURRENT SENSORS

Environment:

Operating Temperature -40 to 60°C (-40 to 140°F)
Storage Temperature -55 to 80°C (-67 to 176°F)

EFCT-1:

Current Ratio 5:0.05 A
Insulation 600-V Class
Window Diameter 82 mm (3.2")
Shipping Weight 0.9 kg (2.0 lb)

Certifications CSA, UL, CE
Compliance RoHS, IEC 60044-1
Extended Operating
Temperature -55 to 60°C (-67 to 140°F)⁽¹⁾

Supplemental
Specifications:

Trip Level Accuracy:
≤ 1 A 1% of CT-Primary Rating
> 1 A 3% of CT-Primary Rating

EFCT-26:

Current Ratio 5:0.05 A
Insulation 600-V Class
Window Diameter 26 mm (1.0")
Shipping Weight 0.45 kg (1.0 lb)
Certifications CSA, UL, CE
Compliance RoHS, IEC 60044-1
Extended Operating
Temperature -55 to 60°C (-67 to 140°F)⁽¹⁾

Supplemental
Specifications:

Trip Level Accuracy:
≤ 1 A 1% of CT-Primary Rating
> 1 A 3% of CT-Primary Rating

SE-CS10-2.5:

Current Ratio 1,000:5 A
Insulation 600-V Class
Window Diameter 63 mm (2.5")
Shipping Weight 0.7 kg (1.5 lb)
Certifications CE
Compliance IEC 60044-1

SE-CS30-26:

Current Ratio 30:0.05 A
Insulation 600-V Class
Window Diameter 26 mm (1.0")
Shipping Weight 0.45 kg (1.0 lb)
Certifications CSA, UL, CE
Compliance RoHS, IEC 60044-1

SE-CS30-70:

Current Ratio 30:0.05 A
Insulation 600-V Class
Window Diameter 70 mm (2.7")
Shipping Weight 1.2 kg (2.5 lb)

Certifications CSA, UL, CE
Compliance RoHS, IEC 60044-1

CT200:

Current Ratio 200:5 A
Insulation 600-V Class
Window Diameter 56 mm (2.2")
Shipping Weight 1 kg (2.2 lb)
Certifications CSA, UL
Compliance RoHS

NOTES:

⁽¹⁾ Electrical specifications have been verified at a Littelfuse lab.

7. ORDERING INFORMATION

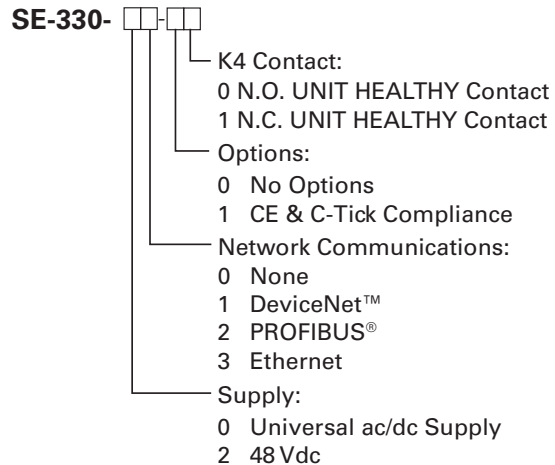

NOTE: Please refer to the SE-330 Product Change Notice (PCN) document for updated ordering information and new revision details, available at www.littelfuse.com/se-330.

NOTE: Each SE-330 includes an SE-330-SMA Surface Mount Adapter.

Sensing Resistors:

ER-600VC For system voltages up to 1 kVac
ER-5KV For system voltages up to 5 kVac
ER-5WP For system voltages up to 5 kVac, weather protected
ER-15KV For system voltages up to 15 kVac
ER-25KV For system voltages up to 25 kVac
ER-35KV For system voltages up to 35 kVac

Current Transformers:

EFCT-1	Ground-Fault CT, 5-A- primary rating, 82-mm (3.2") window, 6m (19.5') of 22 AWG shielded cable included
EFCT-26	Ground-Fault CT, 5-A-primary rating, 26-mm (1.0") window, 6m (19.5') of 22 AWG shielded cable included
SE-CS30-26	Ground-Fault CT, 30-A-primary rating, 26-mm (1.0") window
SE-CS30-70	Ground-Fault CT, 30-A-primary rating, 70-mm (2.7") window

Accessories:

RK-332	Remote Indication and Reset, Includes two 120-V pilot lights, a reset push button, and legend plates
SE-IP65CVR-G	Hinged transparent cover, IP65
SE-MRE-600	Moisture-resistant enclosure for ER-600VC

Software: ⁽¹⁾

SE-FLASH	Firmware Upgrade Program
SE-MON330	SE-330 Data-Display Program for PC
NGR Monitor Set-Point Assistant	Setting Guide

⁽¹⁾ Available at www.littelfuse.com/relayscontrols.

8. WARRANTY

The SE-330 Neutral-Grounding-Resistor Monitor is warranted to be free from defects in material and workmanship for a period of five years from the date of purchase.

Littelfuse Startco will (at Littelfuse Startco's option) repair, replace, or refund the original purchase price of an SE-330 that is determined by Littelfuse Startco to be defective if it is returned to the factory, freight prepaid, within the warranty period. This warranty does not apply to repairs required as a result of misuse, negligence, an accident, improper installation, tampering, or insufficient care. Littelfuse Startco does not warrant products repaired or modified by non-Littelfuse Startco personnel.

Littelfuse Startco is not liable for contingent or consequential damages; for expenses sustained as a result of incorrect application, incorrect adjustment, or a malfunction; or for expenses resulting from the use of, or inability to use, the product.

9. TEST PROCEDURES

9.1 RESISTOR-FAULT TESTS

Perform tests with system de-energized and supply voltage applied to the SE-330.

9.1.1 CALIBRATION AND OPEN TEST

Test Equipment: 20-k Ω and 100-k Ω , 1/4-watt, 1% calibration resistors (calibration resistors are supplied with SE-330).

Procedure:

- Remove connections to terminals 6 and 7.
- Connect the 20-k Ω resistor to terminals 6 and 7.
- Set switch S5 to the 20-k Ω position.
- Perform calibration as per Section 2.2.
- The CALIBRATED LED should be on.
- Press RESET.
- Remove the 20-k Ω resistor and wait for 12 seconds.
PASS: The SE-330 should trip on resistor fault.
- Connect the 100-k Ω resistor to terminals 6 and 7.
- Set switch S5 to the 100-k Ω position.
- Perform calibration as per Section 2.2.
The CALIBRATED LED should be on.
- Press RESET.
- Remove the 100-k Ω resistor and wait for 12 seconds.
PASS: The SE-330 should trip on resistor fault.

NOTE: Resistor-fault-trip reset can take up to one second.

9.1.2 VOLTAGE TEST

Test Equipment: 0 to 120 Vac voltage source and multimeter.

NOTE: Use an isolation transformer if the test-voltage source does not provide dc continuity for the SE-330 resistance-measuring circuit.

NOTE: Applying the test voltage to the R and G terminals will damage the SE-330 and the ER sensing resistor. The V_N TRIP LEVEL is the trip voltage at terminal N, not terminal R.

Procedure:

- Check the ER sensing resistor connection to the SE-330.
- Disconnect the wire from sensing-resistor terminal N. A resistor-fault trip will occur.
- Set the voltage source to 0 V.
- Connect the voltage source between sensing resistor N and G terminals.
- Set the V_N TRIP LEVEL (VAC) to 20.
- Press RESET.
- The RESISTOR FAULT TRIP LED should be off.
- Increase the test voltage to 25 Vac for 20-k Ω sensors or 120 Vac for 100-k Ω sensors and wait 12 seconds
PASS: The SE-330 should trip on RESISTOR FAULT.
For units with firmware Revision 7 or higher, a time-

delayed ground-fault trip follows the resistor-fault trip if neutral voltage persists after the resistor fault

9.2 SENSING-RESISTOR TEST

Test Equipment: Multimeter.

Procedure:

- Disconnect the sensing resistor.
- Measure the resistance between sensing-resistor terminals R and N.
PASS: Resistance should be between 19.6 and 20.4 k Ω for 20-k Ω sensing resistors. Resistance should be between 98 and 102 k Ω for 100-k Ω sensing resistors.
- Measure the resistance between sensing-resistor terminals R and G in both directions.
PASS: Resistance should be greater than 10 M Ω in both directions.

9.3 ANALOG-OUTPUT TEST

Test Equipment: Multimeter with a mA_{dc} scale.

Procedure:

- Connect the 4–20-mA output as a self-powered output as shown in Fig. 3. Measure the current from terminal 20 to terminal 21.
PASS: With no CT current, the analog output should be 4 mA.
- Output is linear to 20 mA. Output is 20 mA when CT-primary current is equal to the CT-primary rating.

9.4 GROUND-FAULT PERFORMANCE TEST

To meet the requirements of the National Electrical Code (NEC), as applicable, the overall ground-fault protection system requires a performance test when first installed. A written record of the performance test is to be retained by those in charge of the electrical installation in order to make it available to the authority having jurisdiction. A test-record form is provided for recording the date and the final results of the performance tests. The following ground-fault system tests are to be conducted by qualified personnel:

- a) Evaluate the interconnected system in accordance with the overall equipment manufacturer's detailed instructions.
- b) Verify proper location of the ground-fault current transformer. Ensure the cables pass through the ground-fault-current-transformer window. This check can be done visually with knowledge of the circuit. The connection of the current-transformer secondary to the SE-330 is not polarity sensitive.
- c) Verify that the system is correctly grounded and that alternate ground paths do not exist that bypass the current transformer. High-voltage testers and resistance bridges can be used to determine the existence of alternate ground paths.
- d) Verify proper reaction of the circuit-interrupting device in response to a simulated or controlled ground-fault current. To simulate ground-fault current, use CT-primary current injection. Fig. 22a shows a test circuit using an SE-400 Ground-Fault-Relay Test Unit. The SE-400 has a programmable output of 0.5 to 9.9 A for a duration of 0.1 to 9.9 seconds. Set the test current to 120% of GF TRIP LEVEL. Fig. 22b shows a test circuit using an SE-100T Ground-Fault-Relay Tester. The SE-100T provides a test current of 0.65 or 2.75 A for testing 0.5- and 2.0-A trip levels. Inject the test current through the current-transformer window for at least 2.5 seconds. Verify that the circuit under test has reacted properly. Correct any problems and re-test until the proper reaction is verified.
- e) Record the date and the results of the test on the attached test-record form.

NOTE: Do not inject test current directly into CT-input terminals 8, 9, 10, and 11.

NOTE: For accurate trip-time measurement, the fault current should not be re-applied for the time defined by the GF TRIP TIME setting to allow the trip accumulator to initialize.

This page intentionally left blank.