

MOUNTING SPECS:

RECOMMENDED FASTENER: M14 OR 9/16"
TIGHTENING TORQUE (REFERENCE ONLY): 92Nm

REV	DATE	DESCRIPTION
A	3/13/20	522085GCP - RELEASE MRY
B	3/23/20	522118ECP/D - UPDATE LENGTH MRY
C	10/25/23	526838ECP/D - ADD VIEW W/O MICROSWITCH MRY

FUSE WITH MICROSWITCH

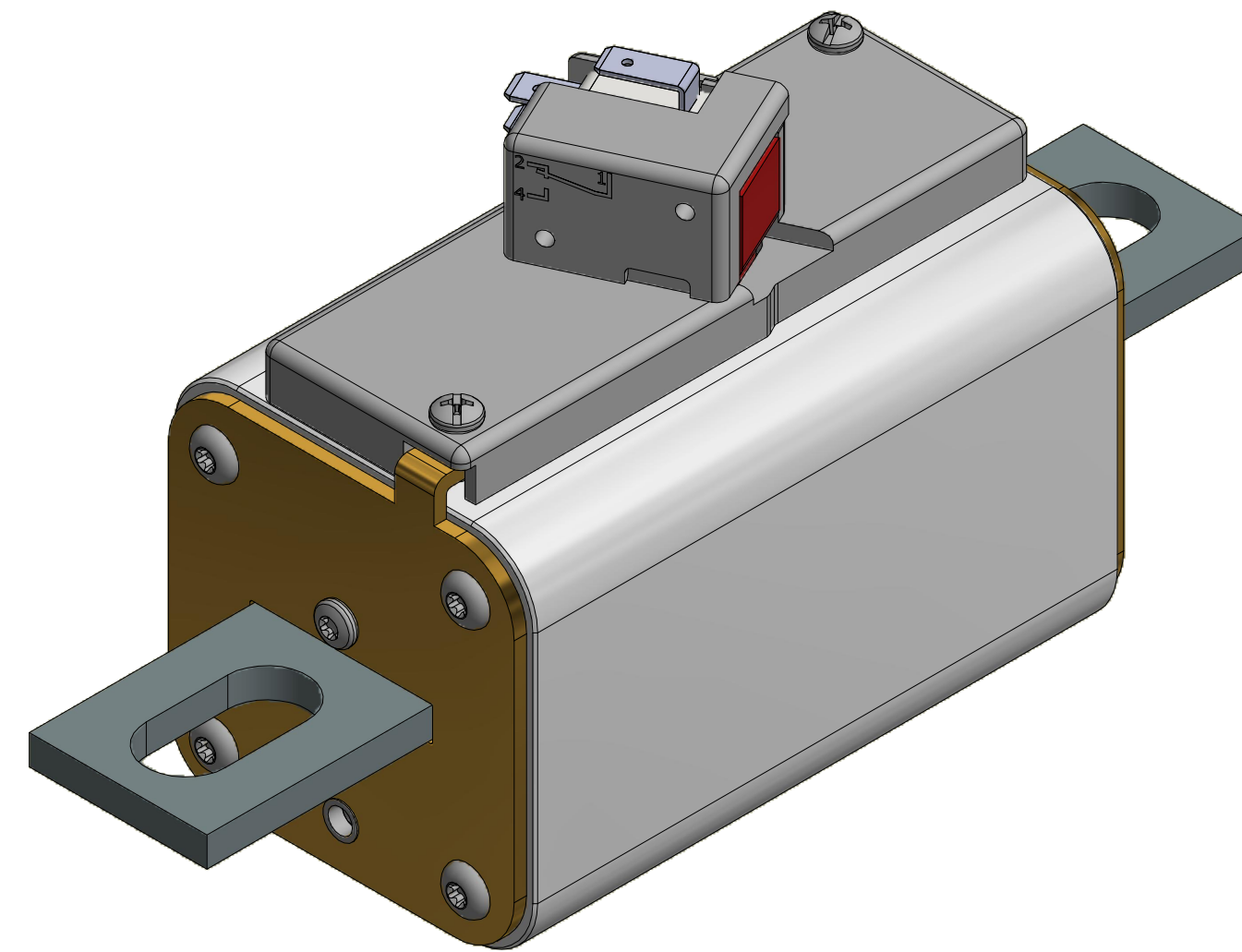
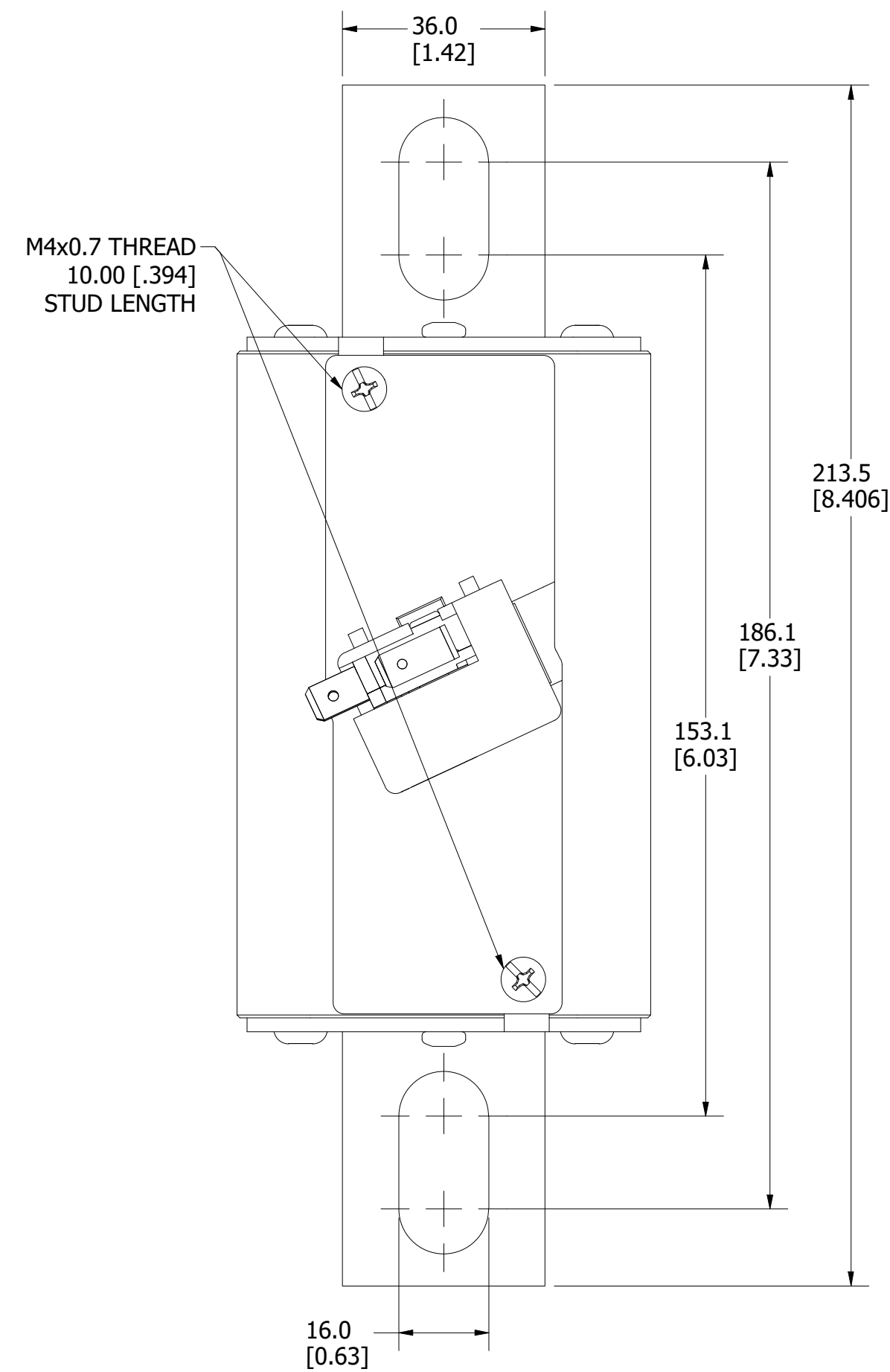

FUSE

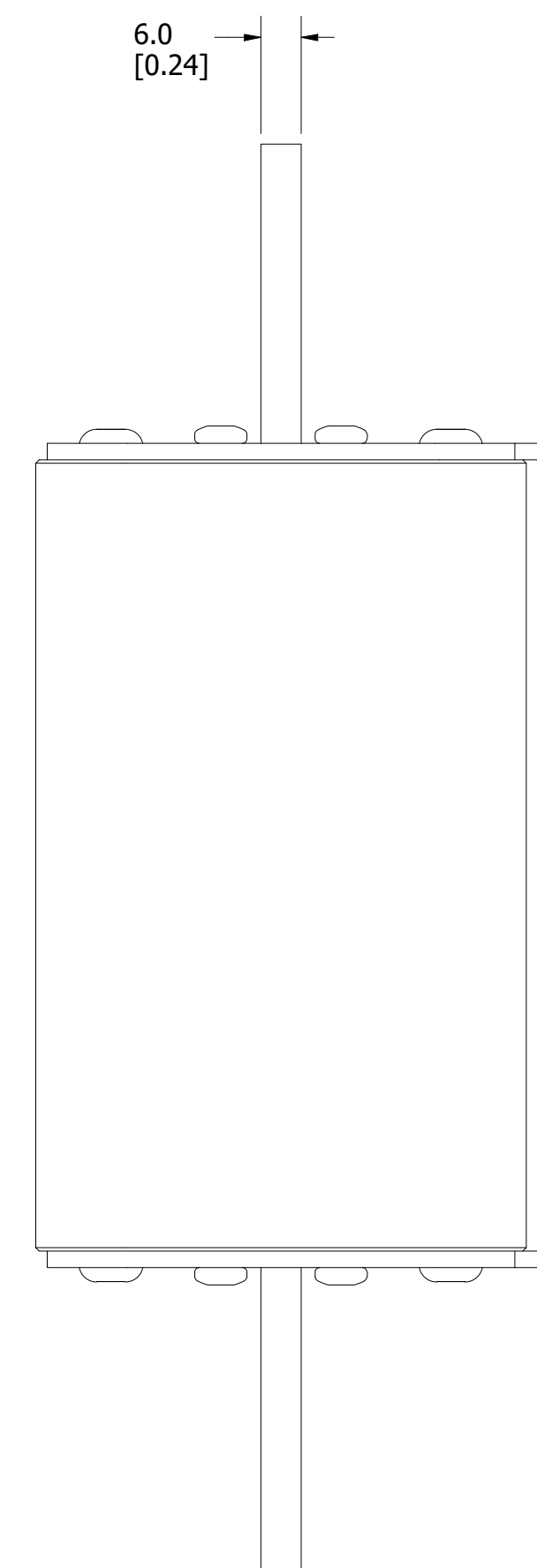

INTERNAL INDICATOR

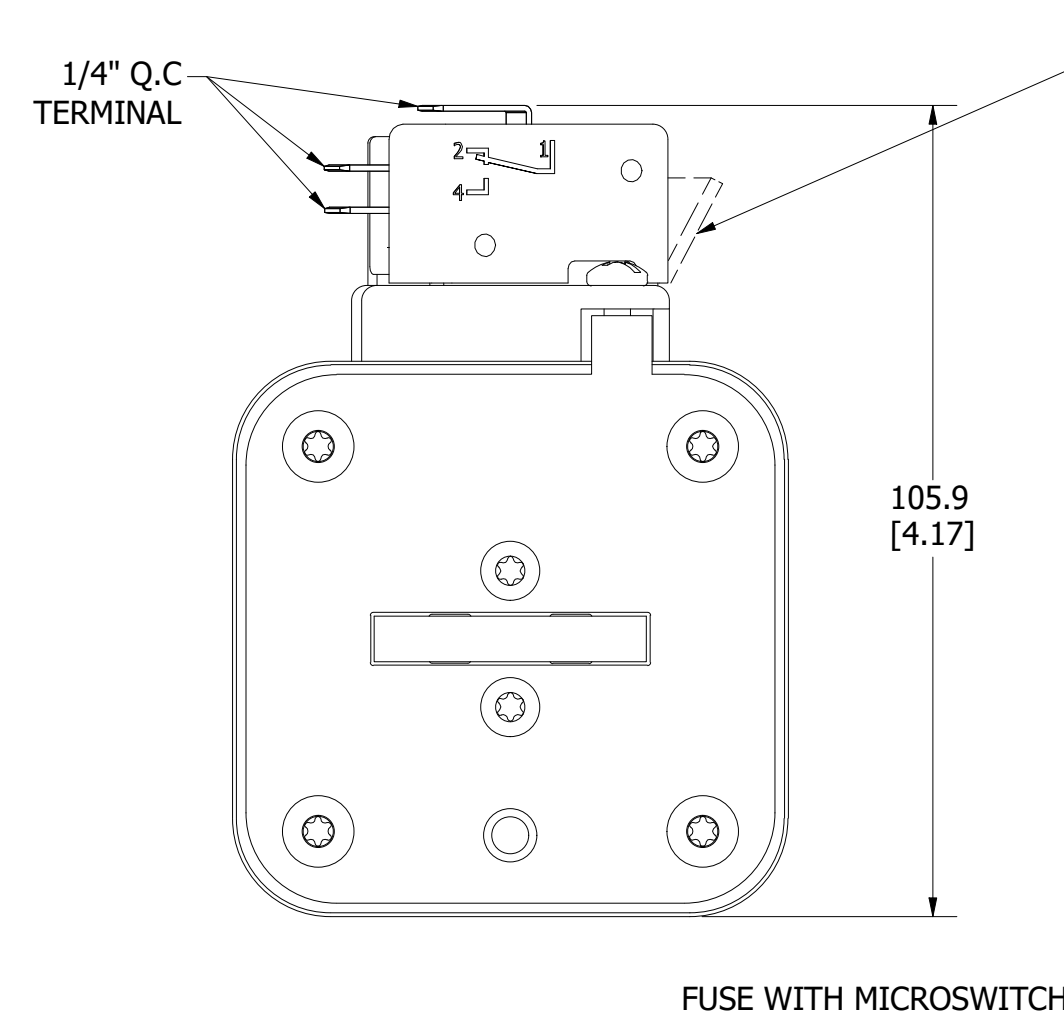
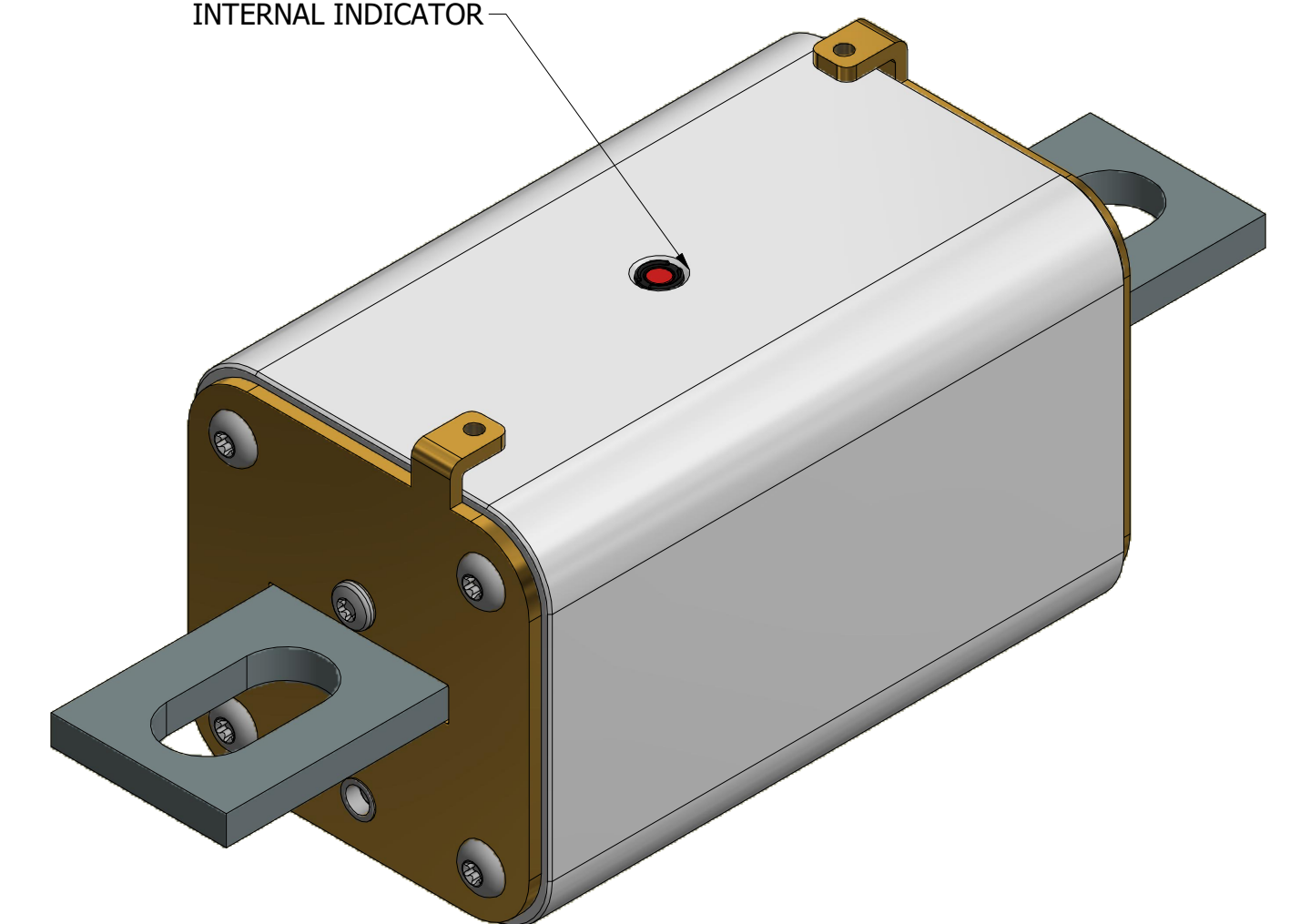

FUSE WITH MICROSWITCH

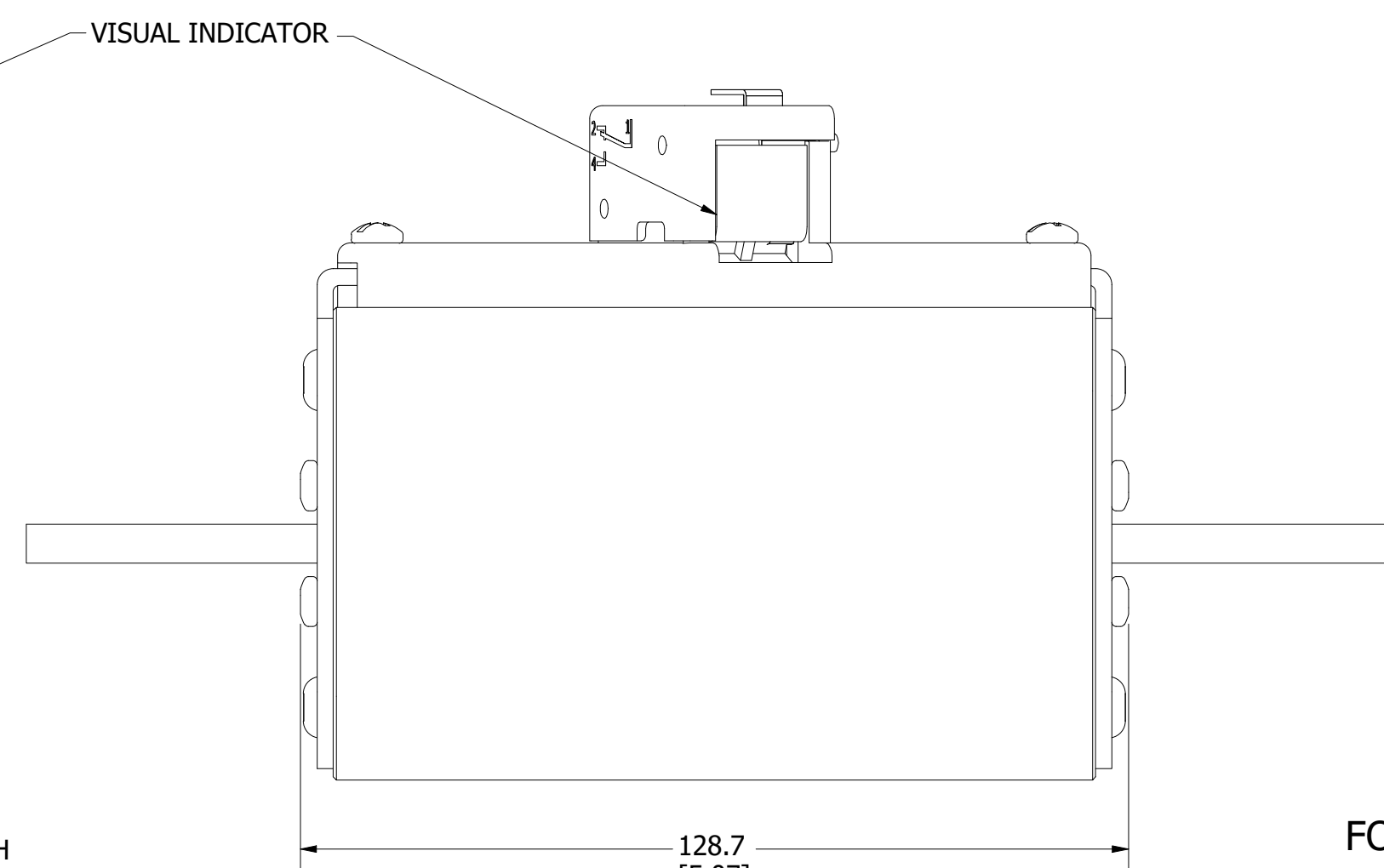

FOR REFERENCE ONLY

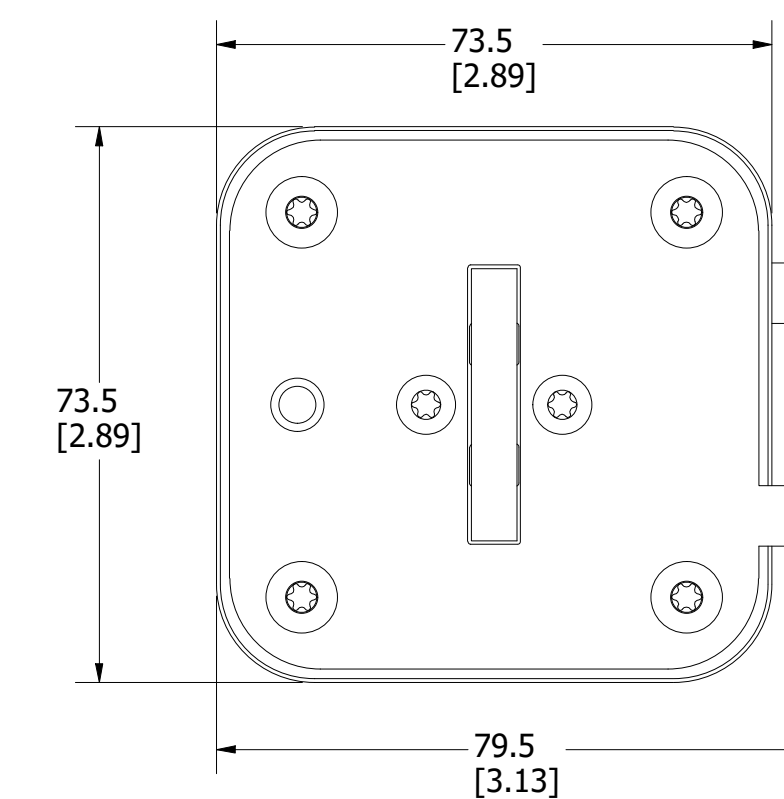

<S>	CRITICAL CHARACTERISTIC FOR PART SAFETY/COMPLIANCE		
●	DENOTES CRITICAL CHARACTERISTICS.		
CPK	DENOTES CPK DIMENSIONS, -MINIMUM CPK VALUE		
Ⓢ	DENOTES A CHARACTERISTIC THAT PROVIDES AN INDICATION OF PROCESS PERFORMANCE. PROCEDURE FOR MEASUREMENT AND TRACKING TO BE DEFINED IN LITTELFUSE INSPECTION INSTRUCTIONS.		
CP	DENOTES CP DIMENSIONS, -MINIMUM CP VALUE MUST BE WITHIN THE DIMENSIONAL LIMITATIONS SHOWN ON DRAWING AND INITIALLY LOCATED TO ALLOW FOR MAXIMUM TOOL LIFE.		
MATL SPEC	DATE	SCALE	FINISH GOOD WT
DRW myork	3/3/2020	NTS	GRAMS/PIECE
UNLESS OTHERWISE SPECIFIED, DIMENSIONS ARE IN MILLIMETERS, DIMENSIONS IN BRACKETS [] ARE INCHES DIMENSIONING AND DO NOT INCLUDE PLATING. TOLERANCING TO BE INTERPRETED IN ACCORDANCE WITH ANSI Y14.5M-1994			
3RD ANGLE PROJECTION			
TITLE	PSX SIZE 3XL BOLTED (UB) FUSE OUTLINE		
	REVISION	DRWG NO.	SHEET 1 OF 1
CHICAGO, ILLINOIS 60631	C	OL-PSX3XLUB0000	