



Expertise Applied | Answers Delivered



PGR-8800  
ARC-FLASH  
RELAY



# APPLICATION GUIDE

## APPLICATION GUIDE

### Table of Contents

<b>1 INTRODUCTION</b> .....	3
1.1 Arc-Flash Relay.....	3
1.2 Optical Sensors.....	3
<b>2 DESIGN</b> .....	4
2.1 Typical Arc-Flash Protection Applications .....	4
2.2 Arcing Faults .....	5
2.2.1 Typical Energy in an Arcing Fault .....	5
2.2.2 Arc-Flash Relays and PPE.....	5
2.2.3 Fault Analysis and Coordination Studies.....	6
2.2.4 Using Littelfuse Arc-Flash Energy Reduction Workbook .....	6
2.3 Interrupting an Arcing Fault.....	7
2.3.1 Interfacing with Local or Upstream Circuit-Breaker Only .....	7
2.3.2 Interfacing with Local Circuit-Breaker and Upstream Circuit-Breaker .....	7
2.4 Electrical Drawings .....	8
2.4.1 PGR-8800 Arc-Flash Relay Back Plate and Sensor Dimensions .....	8
2.4.2 Connections.....	8
2.4.3 Symbols .....	8
<b>3 INSTALLATION</b> .....	9
3.1 Block Diagram .....	9
3.2 Relay Placement .....	9
3.2.1 Maximum Distance to Circuit-Breaker .....	9
3.2.2 Maximum Distance to Sensors .....	10
3.3 Battery Backup .....	10
3.4 Redundant Trip Path.....	11
3.5 Sensor Placement.....	11
3.5.1 Point Sensor Placement.....	12
3.5.2 Fiber-Optic Sensor Placement.....	13
<b>4 CONNECTING MULTIPLE PGR-8800 RELAYS FOR LARGER SYSTEMS</b> .....	14
<b>5 EXAMPLES</b> .....	15
5.1 Light Detection Only .....	15
5.2 Light and Current Detection.....	15
5.3 Tripping of an upstream circuit breaker in case of clearing failures on the local circuit breaker .....	15
5.3.1 Detection of clearing failure through a circuit breaker feedback contact.....	15
5.3.2 Detection of clearing failure through current measurement.....	16
5.3.3 Tripping of the upstream circuit breaker through link interface .....	16
5.4 Simultaneous tripping of an incoming feeder and a tie circuit breaker (main-tie-main application).....	17
5.4.1 Zone detection and isolation using PGA-1100 .....	17
5.4.2 Zone detection and isolation using the link connection.....	17
<b>APPENDIX A: SUPPORTING MATERIALS</b> .....	18

## APPLICATION GUIDE

### 1 INTRODUCTION

#### 1.1 Arc-Flash Relay

The PGR-8800 is a microprocessor-based protection relay that limits arc-flash damage by using light sensors to rapidly detect the arc and then trip a circuit breaker. Phase current-transformer inputs are provided for current-supervised arc-flash protection and can also be used for definite-time overcurrent protection. Sensors, inputs, and trip-coil voltage are monitored to ensure fail-safe operation. A secondary solid-state circuit provides a redundant trip path. A USB port is used for configuration and access to event logs.



The PGR-8800 can be used on electrical systems operating at any voltage (AC or DC) since it does not directly connect to the system. The system is monitored with light sensors and optional current transformers (for AC systems) that can be selected for any current rating. The small size of the PGR-8800 allows installation in any switchgear cubicle, transformer compartment, or motor control center bucket.

#### 1.2 Optical Sensors

The PGR-8800 accepts PGA-LS10 (point), PGA-LS20, PGA-LS25, and PGA-LS30 (fiber) optical sensors. These sensors have been designed to have a wide detection angle and provide the correct sensitivity for an arc flash. LEDs on the relay and on the sensors indicate sensor health and which sensor(s) detected an arc fault. All sensor types include an optical-to-electrical transducer and connect to the PGR-8800 with copper wire.

##### Point Sensor (PGA-LS10)

The point sensor has a detection area of a 2-m half-sphere for arcs of 3 kA or more. Each PGA-LS10 features a built-in LED which enables a PGR-8800 to verify the function of the light sensor, wiring, and electronics. If the relay does not detect the sensor-check LED, a sensor-fail alarm will occur; the ONLINE output will change state, the ONLINE LED will begin to flash, and the sensor LED will show short red flashing. The sensor includes 10 m of shielded three-wire electrical cable which can easily be shortened or extended to a maximum of 50 m.

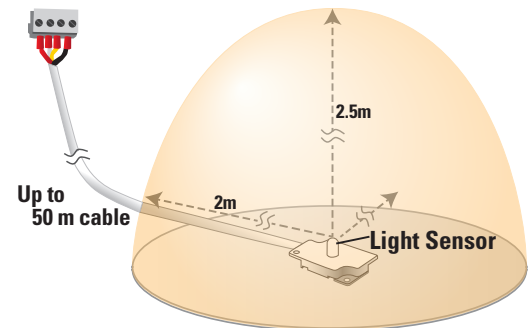

PGA-LS10:  
Detection Range of a 3 kA Arcing Fault

##### Fiber-Optic Sensor (PGA-LS20, PGA-LS25, PGA-LS30)

The fiber-optic sensor has a 360° detection zone along the fiber's length (8 m for the PGA-LS20, 5 m for the PGA-LS25, 18 m for the PGA-LS30). Each PGA-LS20, PGA-LS25, and PGA-LS30 features a built-in LED which enables the PGR-8800 to verify the function of the fiber-optic light sensor, wiring, and electronics. If the relay does not detect the sensor-check LED, a sensor-fail alarm will occur; the ONLINE output will change state, the ONLINE LED will begin to flash, and the sensor LED will show short red flashing.

The fiber-optic sensors have three components:

1. A fiber-optic cable bundle terminating on both ends, one end covered with a black sleeve, and the other is uncovered. Both ends are terminated at the factory.
2. A transmitter with a white enclosure and a white thumb nut.
3. A receiver with a white enclosure, a black thumb nut, and an adjustment screw behind an access hole.

Both the receiver and the transmitter connect to a single input on the PGR-8800 using shielded three-wire electrical cable. The receiver and transmitter each include 10 m of shielded three-wire electrical cable that can easily be shortened or extended to a maximum of 50 m. All three components are monitored to ensure continuity and correct operation.

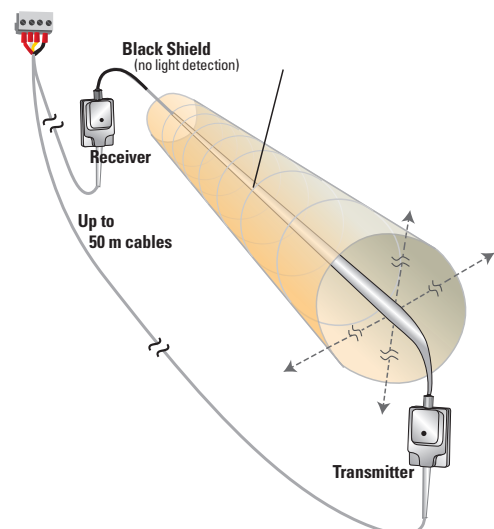

PGA-LS20: Active Length of 8 m  
 PGA-LS25: Active Length of 5 m  
 PGA-LS30: Active Length of 18 m

## APPLICATION GUIDE

### *Fiber*

The fiber is the light-collecting element of the PGA-LS20, PGA-LS25, and PGA-LS30. It must be installed so it has line-of-sight to all current-carrying parts. In some cases this may be accomplished by mounting in a position that follows the bus bars along the back wall of the cabinets.

Connect the black-sleeve-covered end to the receiver using the black thumb nut, and the white uncovered end to the transmitter using the white thumb nut. Ensure the fiber is inserted completely into the transmitter and receiver and the nuts are tightened. Pull gently on the electrical cable to verify a secure connection.

The fiber should not be sharply bent or pinched. The minimum bending radius is 5 cm.

### *Point or Fiber-Optic Sensors?*

The PGR-8800 supports two types of arc-flash sensors, point sensors (PGA-LS10) and fiber-optic sensors (PGA-LS20, PGA-LS25, and PGA-LS30). Both sensor types gather light and transmit the intensity of the light back to the PGR-8800. The point sensor monitors the light from a single collection point while the fiber-optic sensors collect light along their entire length. The decision to use point sensors or fiber-optic sensors comes down to the geometry of the equipment to be monitored and the importance of fault location. In a switchgear installation with many small cabinets, it may be more cost-effective to pass a single fiber-optic sensor through all the cabinets than to install one point sensor per cabinet. However, this is done at the expense of using the fault location features of the PGR-8800 to determine the location of the arc-flash within those cabinets, not which sensor sees the fault. Sensor types can be combined to further customize the solution. An understanding of the two sensor types and their properties is important for selecting the correct sensors.

## 2 DESIGN

### 2.1 Typical Arc-Flash Protection Applications

Although an arc flash is improbable on systems operating at 208 V or less, systems with higher voltages have sufficient capacity to cause an arc flash and should use proper protection. Arc-flash protection is especially important in the following applications:

- **Solidly grounded electrical distribution systems:** It is estimated that over 95% of all electrical faults are, or begin as, a ground fault.\* Ground-fault current on a solidly grounded system is only limited by the resistance of the fault and system impedance, and has the potential to cause an arc flash.
- **Air-cooled transformers:** On air-cooled equipment, the winding insulation, terminals, and ground points are exposed to the environment. Pollution, dust, and other contaminants can cause premature insulation failure and can lower the resistance of the air gap between energized conductors, and between energized conductors and ground. Insulation failure and lower air-gap resistance increase the probability of an arc flash.
- **Rack-out breakers:** As a circuit breaker is racked out, there is a potential for an arc flash to develop when the electrical contacts are disconnected while energized.
- **Non-insulated bus.**
- **Ungrounded and resistance-grounded system:** Systems that are alarm only, and don't remove faults in a timely fashion.
- **Devices with high inrush currents:** Transformers, capacitor-banks, surge arrestors, large motors, and other reactive loads will cause a high-inrush current when energized. To allow these systems to operate properly, instantaneous-current settings on circuit breakers will either be set very high or not used, allowing an arc-flash to remain on the system for longer, or not be detected at all.

\*Source: *Industrial Power System Grounding Design Handbook* by J.R. Dunki-Jacobs, F.J. Shields, and Conrad St. Pierre, page xv.

## APPLICATION GUIDE

- **Medium and high-voltage equipment:** Medium-voltage equipment (4160 V and higher) often uses air insulation
- **Moveable and mobile electrical equipment:** Mobile electrical equipment is subject to physical damage while in motion and has a higher potential for an arc flash. The designs are often more compact, reducing air gap insulation levels
- **Areas where work or maintenance is regularly performed on energized equipment:** While maintenance personnel are required to wear proper PPE when working on or around energized equipment, an arc-flash relay can be used to lower the levels of hazard that personnel are exposed to.
- **Older facilities:** Where often, room is not available for any other means of Arc-Flash Hazard mitigation.

### 2.2 Arcing Faults

#### 2.2.1 Typical Energy in an Arcing Fault

A phase-to-phase fault on a 480-V system with 20,000 amperes of fault current provides 9,600,000 watts of power. Imagine that there is no arc protection and the fault lasts for 200 milliseconds before the overcurrent protection clears it. The released energy would be 2 MJ, which corresponds roughly to a stick of dynamite.

The energy formula is as follows:

$$\text{Energy} = \text{voltage} \times \text{current} \times \text{time} = 480 \text{ V} \times 20,000 \text{ A} \times 0.2 \text{ s} = 1,920,000 \text{ J}$$

For a given system voltage, two factors can be adjusted to reduce arc-flash energy: time and current

Time can be reduced by using a device such as the PGR-8800 to rapidly detect an arc flash, thus causing the connected circuit breaker to trip at its instantaneous speed, overriding any inverse-time delay. Current can be reduced by using current-limiting fuses or, in case of phase-to-ground faults, by using high-resistance grounding.

#### 2.2.2 Arc-Flash Relays and PPE

Reducing the clearing time is typically a trade-off with system uptime for current-based protection. Sufficient delay is required to prevent unnecessary tripping on momentary overload or current spikes. Such delay limits how quickly such a system can react.

Arc-flash relays address this issue by detecting light rather than current, which permits a much faster response that is independent of current spikes and momentary overloads. The PGR-8800 relay can detect an arcing condition and send a trip signal to a circuit breaker in less than 1 ms. This response time is much faster than standard current-based protection, which means using an arc-flash relay will lower the incident energy or arc-flash hazard in most cases. This results in increased worker safety, less fault damage, and improved uptime.

If the arc-flash incident energy has decreased, the associated PPE requirement may also be lowered. The exact improvement will depend on the installation, so the PGR-8800 must be modeled in the system to determine the new incident energy and PPE.

## APPLICATION GUIDE

### 2.2.3 Fault Analysis and Coordination Studies

The PGR-8800 is listed in several leading system analysis software packages.

Below is an example of the PGR-8800 in a software package.

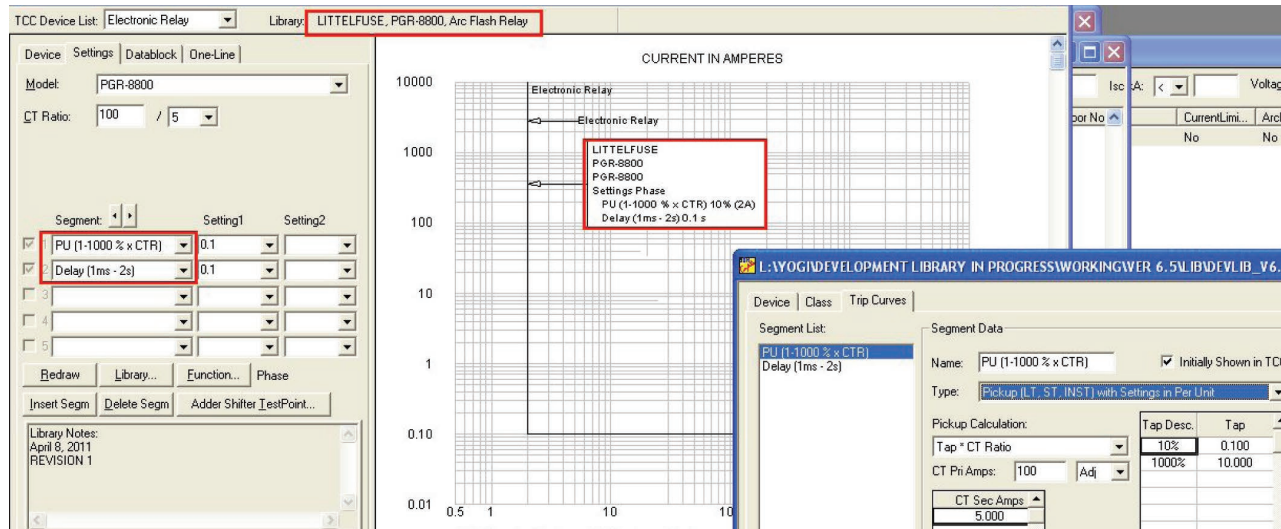

For arc-flash protection, the PGR-8800 must detect light of sufficient intensity to initiate the tripping sequence. If current inhibit is enabled, the PGR-8800 will not send a trip signal unless there is also sufficient current. Both light and current trip levels can be adjusted. The PGR-8800 also has two settings for overcurrent protection.

Currently, no software package models light detection. Because the reaction time of the PGR-8800 does not vary with current, the PGR-8800 is simply a horizontal line on the time-current curve (TCC). The opening time or clearing time must include all devices in the sequence, which includes the shunt-trip or undervoltage operating time as well as clearing times. This clearing time value can be used in the software as a user-defined trip time or the PGR-8800 library model can be used with the current set to a low value to reproduce the current-independent characteristic of optical detection.

Regular maintenance of equipment is recommended to insure it will operate when required.

Bolted Pressure Switches (BPS) can also be used, but many of these devices have limitations in terms of interrupting and clearing time rating, so the user must check the ratings first. With either a circuit breaker or BPS, the opening time or clearing time can be modeled in the software. Verify either device is rated to interrupt the maximum fault current possible.

### 2.2.4 Using Littelfuse Arc-Flash Energy Reduction Workbook

The purpose of the Littelfuse Arc-Flash Energy Reduction Workbook (PF710) is to help the plant engineer or electrician create a preliminary calculation of the reduction of Incident Energy if applying the PGR-8800 Arc-Flash Relay. All nameplate data should be collected by a qualified individual.

## APPLICATION GUIDE

### 2.3 Interrupting an Arcing Fault

#### 2.3.1. Interfacing with Local or Upstream Circuit-Breaker Only

Refer to the product manual to configure the PGR-8800 to work with local circuit breaker, shunt trip or undervoltage trip coil.

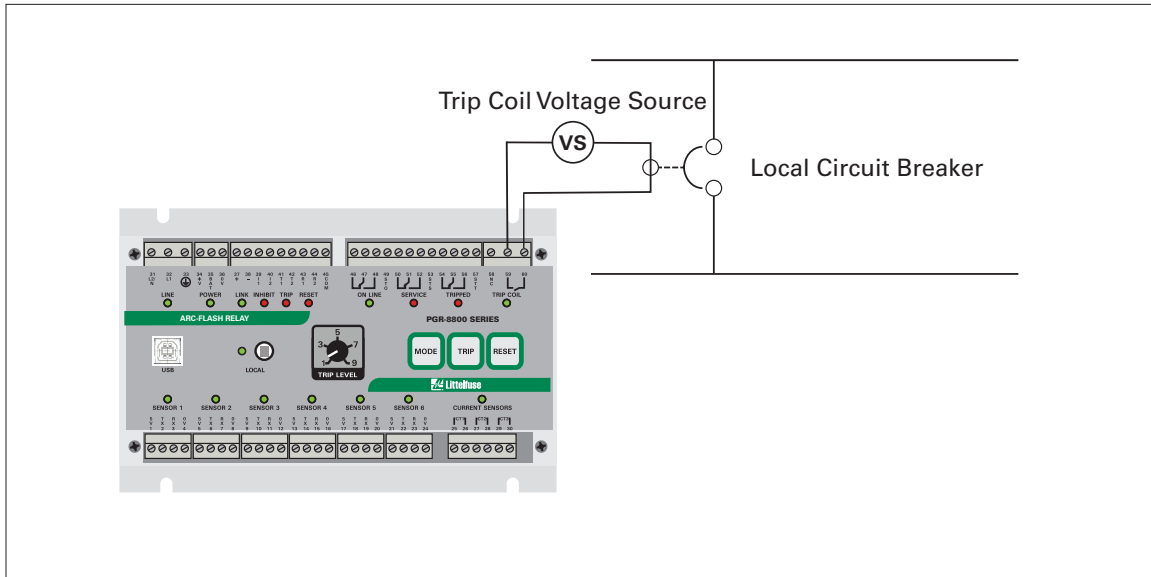

#### 2.3.2 Interfacing with Local Circuit-Breaker and Upstream Circuit-Breaker

Refer to the product manual to setup the PGR-8800 to work with local circuit breakers and optional upstream circuit breakers, which can be tripped in the event of a breaker failure.

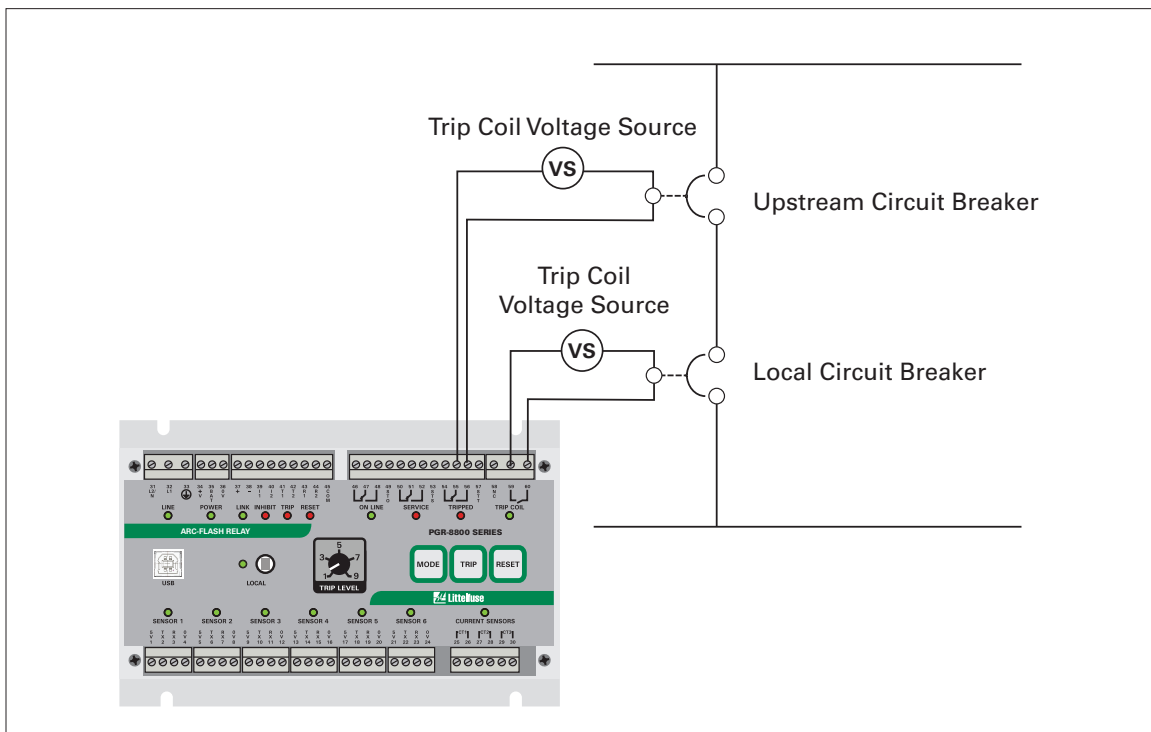

## APPLICATION GUIDE

### 2.4 Electrical Drawings

#### 2.4.1 PGR-8800 Arc-Flash Relay Back Plate and Sensor Dimensions

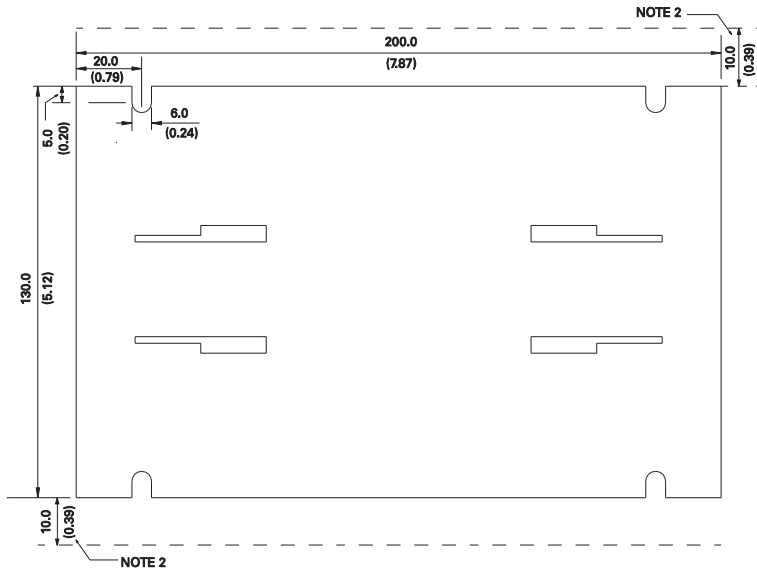

- NOTES:
1. DIMENSIONS IN MILLIMETRES (INCHES).
  2. MINIMUM CLEARANCE REQUIRED FOR CONNECTOR INSERTION AND REMOVAL.

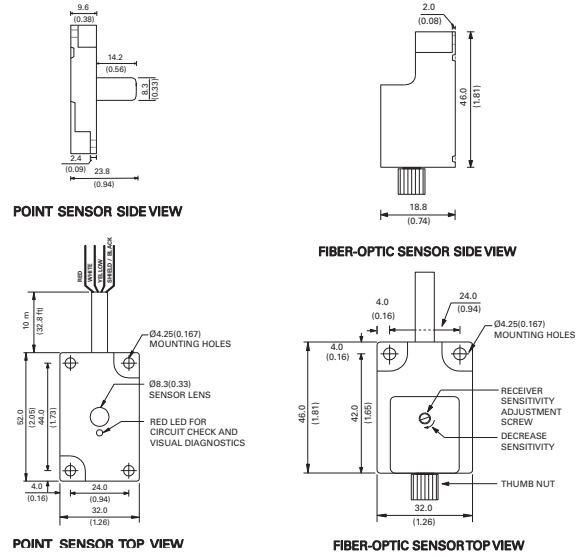

PGA-LS10

PGA-LS20, PGA-LS25 and PGA-LS30

#### 2.4.2 Connections

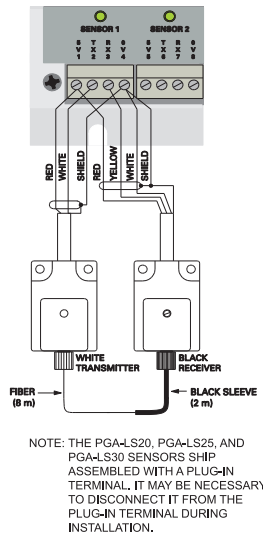
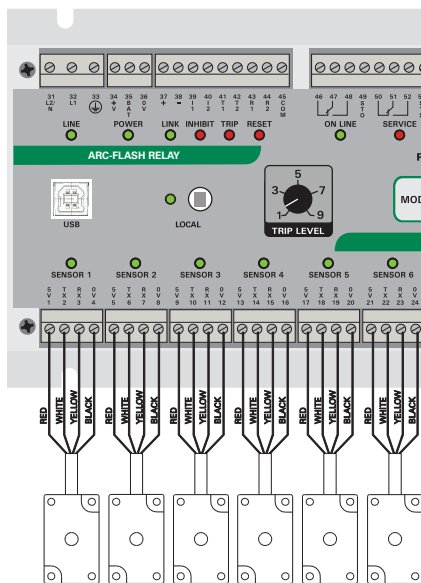

- NOTES: 1. UP TO 6 PGA-LS10 POINT SENSORS WITH BUILT-IN CIRCUIT CHECK CAN BE CONNECTED.
2. THE PGA-LS10 SENSOR SHIPS ASSEMBLED WITH A PLUG-IN CONNECTOR. IT MAY BE NECESSARY TO DISCONNECT THE PLUG-IN CONNECTOR DURING INSTALLATION.

#### 2.4.3 Symbols

These symbols are to be used in electrical drawings of the PGR-8800:



PGR-8800 Arc-Flash Relay

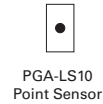



## APPLICATION GUIDE

### 3 INSTALLATION

#### 3.1 Block Diagram

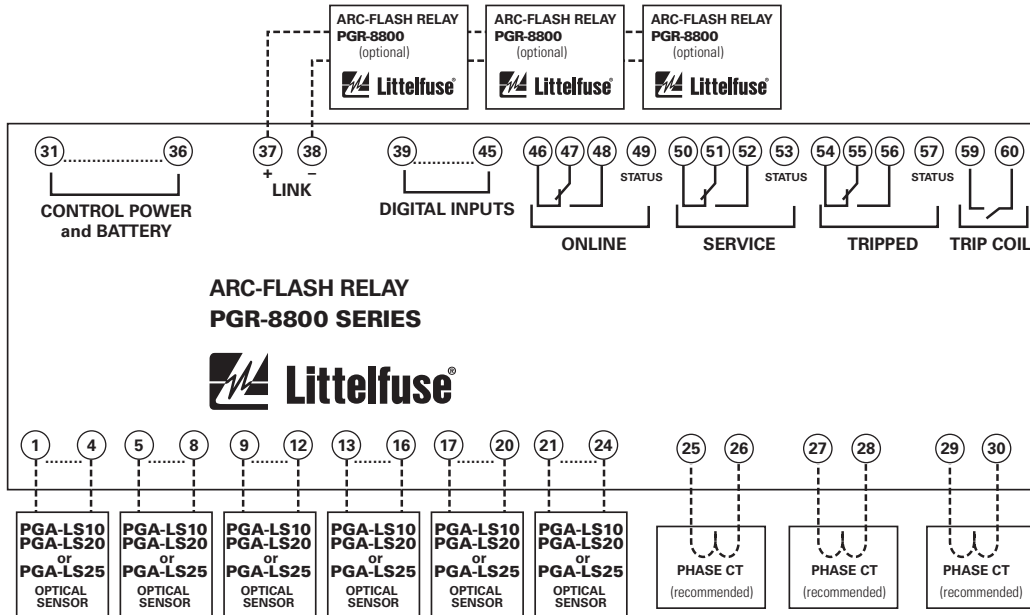

Note: The link connection on ports 37 and 38 can alternatively be used for Modbus communication.

#### 3.2 Relay Placement

##### 3.2.1 Maximum Distance to Circuit-Breaker

In order to determine the maximum permitted distance, the following data is required:

- Burden of the shunt trip-coil (see data sheet of shunt trip)
- Available trip voltage in the installation
- Permitted voltage range of the trip coil (lowest permitted voltage for the shunt trip to operate, see data sheet of the shunt trip)
- Wire material and specific electrical resistance of that material

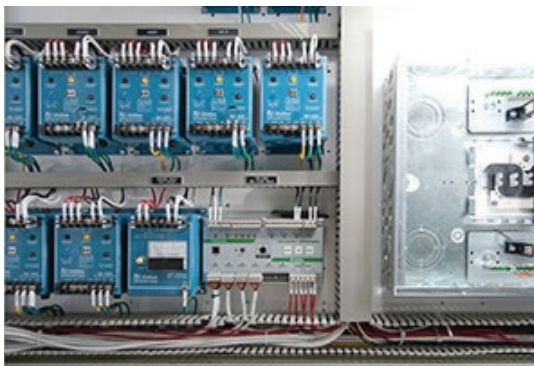

## APPLICATION GUIDE

### Calculation Definitions and Example

VARIABLE	DEFINITIONS
<b>S</b>	Burden of the shunt trip [VA]
<b>L</b>	Cable length
$\rho$	Specific electrical resistance (copper is 0.0178) $\frac{\Omega \times \text{mm}^2}{\text{m}}$
<b>U</b>	Available trip voltage in the installation
<b>U<sub>min</sub></b>	Lowest permitted voltage for the shunt trip to operate
<b>U<sub>IGBT</sub></b>	Voltage drop across the IGBT (4 V for the PGR-8800 IGBT)
<b>U<sub>drop</sub></b>	Maximum voltage drop permitted over the cable between the shunt trip and the PGR-8800
<b>A</b>	Cable cross section [mm <sup>2</sup> ]

### Example Values

$$\begin{aligned}
 \mathbf{S} &= 185 \text{ VA} & \mathbf{U}_{\min} &= 12 \text{ V} \\
 \rho &= 0.0178 \frac{\Omega \times \text{mm}^2}{\text{m}} \quad (\text{Copper Wire}) & \mathbf{U}_{\text{IGBT}} &= 4 \text{ V} \\
 \mathbf{U} &= 24 \text{ V} & \mathbf{A} &= 2.5 \text{ mm}^2
 \end{aligned}$$

### Calculation of the Permitted Cable-Voltage Drop

$$U_{\text{drop}} = U - U_{\min} - U_{\text{IGBT}} = 24 \text{ V} - 12 \text{ V} - 4 \text{ V} = 8 \text{ V}$$

### Calculation of Nominal Trip Current

$$\begin{aligned}
 \mathbf{S} &= U \times I \\
 \mathbf{I} &= \frac{\mathbf{S}}{\mathbf{U}} = \frac{185 \text{ VA}}{24 \text{ V}} = 7.71 \text{ A}
 \end{aligned}$$

Note that the nominal trip current is calculated with the full 24 V. Due to voltage drop across the IGBT and cable, the full trip voltage will not be present at the coil. When a lower voltage is available at the trip coil, the trip coil will operate with a lower current. This gives some additional safety margin.

### Calculation of Maximum Allowed Cable Resistance

$$\mathbf{R} = \frac{U_{\text{drop}}}{\mathbf{I}} = \frac{8 \text{ V}}{7.71 \text{ A}} = 1.04 \Omega$$

### Calculation of Maximum Cable Length

$$\begin{aligned}
 \rho &= R \times \frac{\mathbf{A}}{\mathbf{L}} \\
 \mathbf{L} &= \frac{R \times \mathbf{A}}{\rho} = \frac{1.04 \Omega \times 2.5 \text{ mm}^2}{0.0178 \frac{\Omega \times \text{mm}^2}{\text{m}}} = 117 \text{ m} / 2 = 58 \text{ m}
 \end{aligned}$$

The maximum distance between the PGR-8800 trip coil output and trip coil for above example is 58 m. If the PGR-8800 is installed far from the circuit breaker, higher voltage trip coils can be used to reduce the current draw and therefore the voltage drop on the wire.

### 3.2.2 Maximum Distance to Sensors

The maximum length of electrical cable between a PGA-LS10 point sensor and a PGR-8800 is 50 m. The maximum length of electrical cable between a PGA-LS20/PGA-LS25/PGA-LS30 fiber-optic sensor and a PGR-8800 is 50 m to the transmitter module and 50 m to the receiver module.

### 3.3 Battery Backup

The PGR-8800 has the ability to use a 24 Vdc battery as an Uninterrupted Power Supply (UPS), charging the battery when supply voltage is present and switching to the battery when main power is lost. It may seem unnecessary to have arc-flash protection if power is not present, but it is not always the case that the PGR-8800 is supplied by the same system that it is protecting. A loss in supply voltage for the PGR-8800 does not always mean that the equipment being monitored has lost power. In these cases, it is important to always have arc-flash protection.

## APPLICATION GUIDE

### 3.4 Redundant Trip Path

The PGR-8800 has a secondary solid-state circuit that provides redundancy in the event of a microprocessor failure. Less often considered, a microprocessor-based relay can take several hundred milliseconds to initialize and reach the state where it is able to detect an arc flash. If the system is de-energized for maintenance (including the PGR-8800) and then re-energized when the maintenance is complete, this constitutes a risk. A misplaced tool or incorrect wiring that was changed during shutdown could result in an arc flash immediately on power up. In this case the redundant trip path will protect the system against arc flashes during initialization of the microprocessor as well, thus the system allows a much faster response time on power up than typical microprocessor-based relays. The response time after power up would be 4 ms for DC supply and 40 ms for AC supply. This is much faster than waiting for initialization of the microprocessor. The best solution to keep the response time quick is to keep the PGR-8800 powered up by use of a battery backup.

### 3.5 Sensor Placement

The PGR-8800 Arc-Flash Relay and sensors are easily installed in retrofit projects and new switchgear with little or no reconfiguration. Even elaborate systems with multiple power sources take only minutes to configure using the relay's built-in USB PC-interface software. (No need to install any configuration software on the PC)

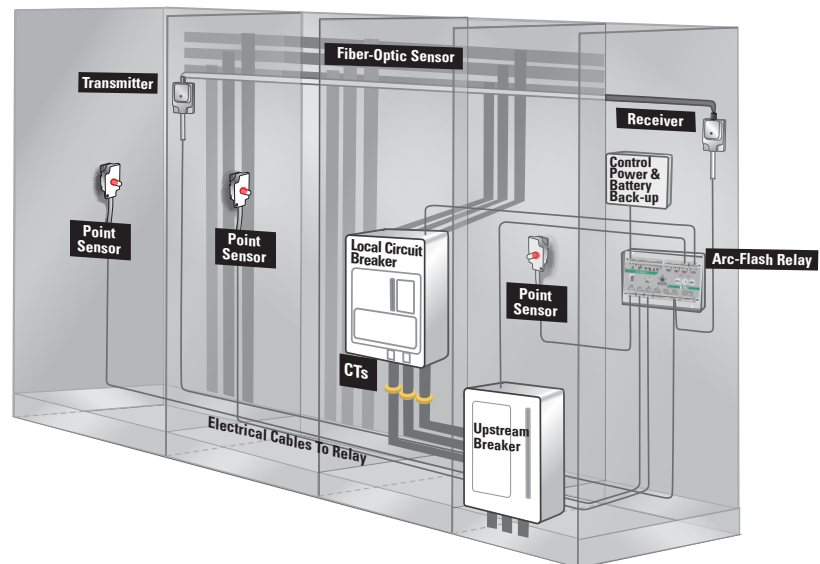

Generally, it is recommended to mount 1 or 2 sensors per cubicle to cover all horizontal and vertical bus bars, circuit breaker compartments, drawers, and anywhere that there is potential for an arc fault. Threading a fiber-optic sensor through the cabinets and in areas where point-sensor coverage is uncertain results in complete coverage and an added level of redundancy (at least 60 cm per compartment). Even if policy is to only work on de-energized systems, all maintenance areas should be monitored to prevent potential damage and additional costs. At least one sensor should have visibility of an arc fault in the event that someone were to block the other sensor(s).

#### *Additional guidelines*

- Ensure fiber-optic light sensors and electrical cables are not blocked by objects, either fixed or movable.
- Do not place point sensors or fiber-optic sensor on live or energized components.
- Choose a location that will minimize collection of foreign debris and be easy to inspect/maintain.
- Use care when handling, pulling, and securing electrical cables and sensors.
- Avoid sharp bends (<5 cm) and high temperature (>80°C).
- Consider potential light emitted from air-magnetic circuit breakers when placing sensors.
- Even though the sensors and electrical cables have no exposed live parts and are fully insulated, the placement and routing must comply with industry-standards for over-surface (creep) and through-air (clearance) requirements.
- Label equipment so that workers are aware that light detection technology is present. Avoid direct sunlight, flash photography and welding if the sensors are exposed and current inhibit is not used.

## APPLICATION GUIDE

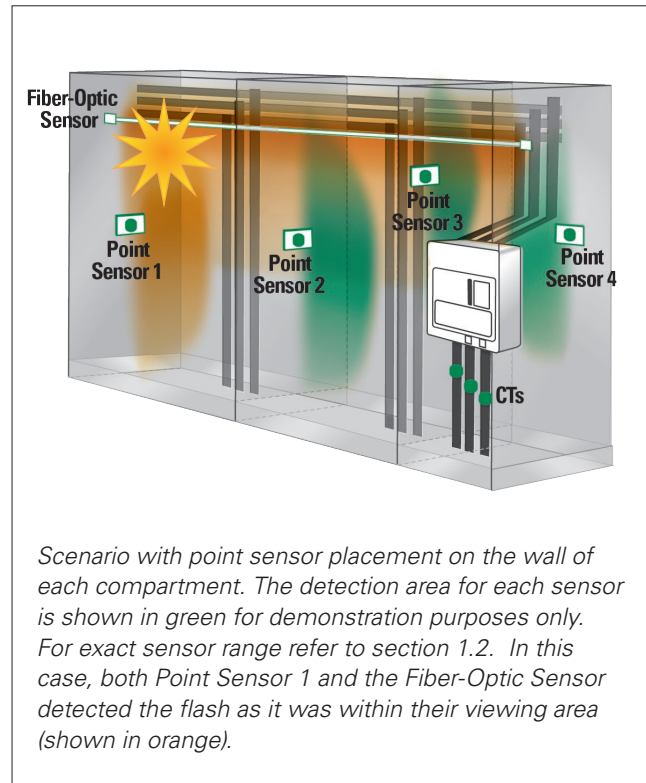
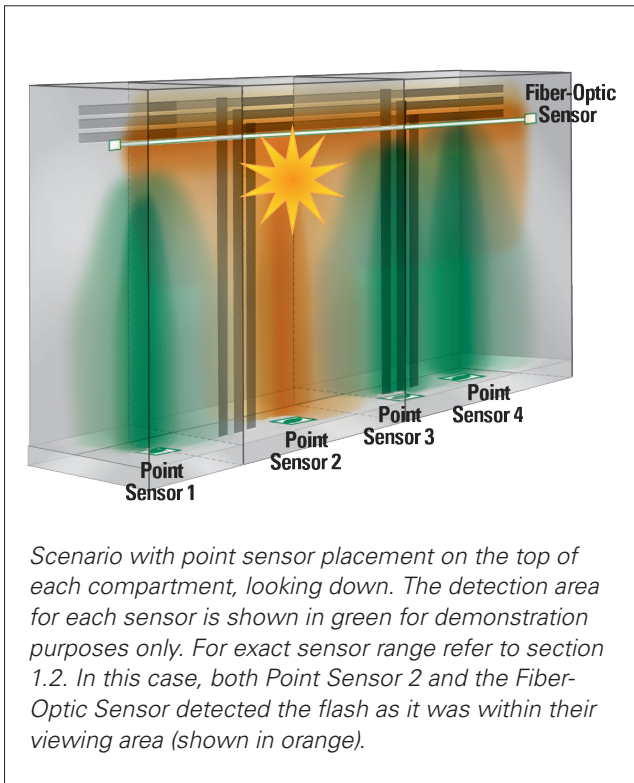

### 3.5.1 Point Sensor Placement

The point-sensor (PGA-LS10) housing directs light from a half-sphere detection volume onto the light sensor. An arc flash can conduct tens of thousands of amps but, for an arc flash of only 3 kA, a PGA-LS10 has a half-sphere detection range of 2 m or more. A point sensor is apt at indicating the fault location because the light is only collected at one location. However, the requirement for direct line-of-sight can be a disadvantage in areas with a lot of equipment and poor sight lines. In most enclosures, the metallic walls can reflect the light onto the sensor, thereby amplifying the light incident on the sensor. However, walls create an extra safety issue — an arc flash in a location not directly visible by the sensor might not be detected.



*Examples of appropriate point sensor installation.*

The PGA-LS10 point sensors can be installed up to 50 m from the PGR-8800 Arc-Flash relay with standard shielded 3-wire electrical cable. This is a benefit for retrofit applications as electrical cable is more durable and easier to install than a fiber-only installation between sensor and relay. Electrical cable has high tolerance for electrical noise (although not as high as a fiber-optic sensor), and for the purposes of electrical clearances, should be treated as though it is a bare conductor at ground potential.

## APPLICATION GUIDE

### 3.5.2 Fiber-Optic Sensor Placement

The fiber-optic sensor (PGA-LS20, PGA-LS25 and PGA-LS30) has three components. There is an optical fiber bundle, a transmitter and a receiver, to convert light collected by the fiber into an electric signal that can be sent to the relay. Unlike most fiber-optic sensors which transmit light from one end to the other without letting any light escape, the fiber-optic sensor is designed to trap light along its entire length and then prevent that light from escaping. One end of the fiber is shielded for 2 m (minimum) as light entering in this location will be detected more intensely (than the same light further down the sensor) which could cause incorrect measurement.

Transmitter and receiver modules can be installed up to 50 m from the PGR-8800. The fiber should not be in contact with bare conductors but can be run much closer than the electrical cables and point sensor, which can make it a better choice for small and dense spaces with lots of shadow and little clearance. The active lengths of the PGA-LS20, PGA-LS25, and PGA-LS30 are 8 m, 5 m, and 18 m respectively.

Make sure that at least 60 cm of fiber are exposed in each compartment, in order to collect sufficient light. Fibers must be handled with care as they are more fragile than electrical cable, have a minimum radius for curves, and may be damaged during installation. A fiber-optic sensor does not detect the exact location of an arc along the fiber, it just detects an arc. It may not be immediately clear where the arc-flash was detected if the sensor is passed through many compartments. However, passing the fiber-optic sensor through many small compartments may result in a significant cost savings as compared to using an individual point sensor in each compartment. Each PGR-8800 accepts up to six sensors, so an application with seven or more compartments would require at least two relays in addition to seven or more point sensors. The same application could possibly be protected with a single fiber-optic sensor and relay.

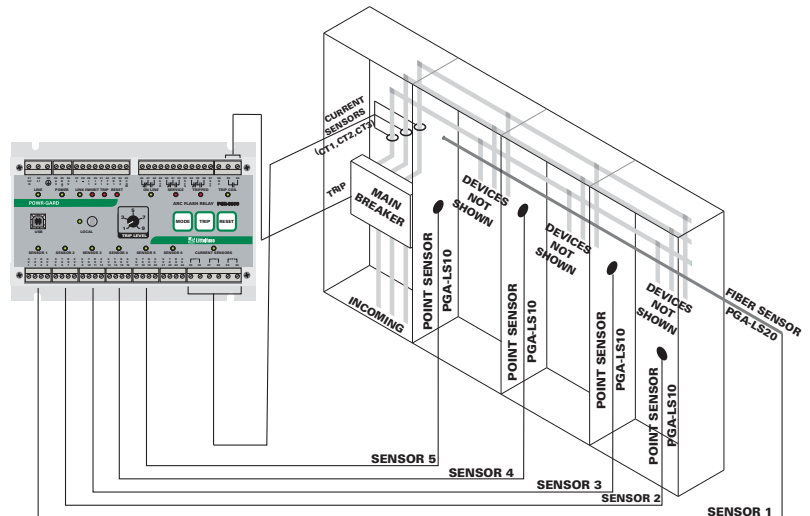

PGA-LS20 10m (8m active)  
 PGA-LS25 8m (5m active)  
 PGA-LS30 20m (18m active)

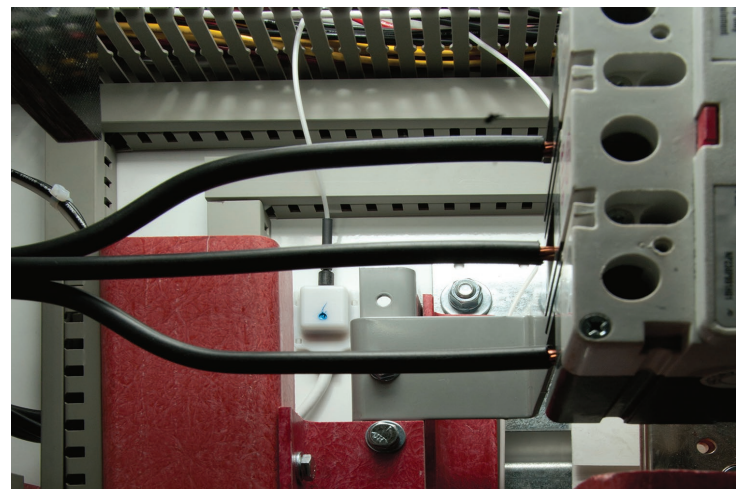

Example of appropriate fiber optic sensor installation.

## APPLICATION GUIDE

### 4 CONNECTING MULTIPLE PGR-8800 RELAYS FOR LARGER SYSTEMS

The PGR-8800 Link function allows up to four PGR-8800 relays to be connected to form a single system. This enables the PGR-8800 to share sensor inputs and relay outputs as if they were one unit.

It is necessary to configure the Link function before use.

#### Link Configuration

- The Link interface and link address are set up with the configuration software. See manual for more information.
- Each PGR-8800 must have a unique link address, starting from 1 for the module connected to the circuit breaker.
- The PGR-8800 Link function continuously monitors for communications-cable-break faults and therefore, it is necessary to program the number of connected relays.

#### Push-Button Function

When a PGR-8800 is configured for the Link function, the front push buttons can be shared with all relays in the system or set to apply only to the local relay. For example, if one PGR-8800 is set to SERVICE mode and interface sharing is enabled, all the linked relays will be placed in SERVICE mode. This also applies to the RESET push button. (The MODE push button switches the PGR-8800 between ONLINE and SERVICE mode.)

The TRIP push button is only applied locally. If the TRIP push button is pressed in SERVICE mode, the module where the button was pressed will be the only one that trips.

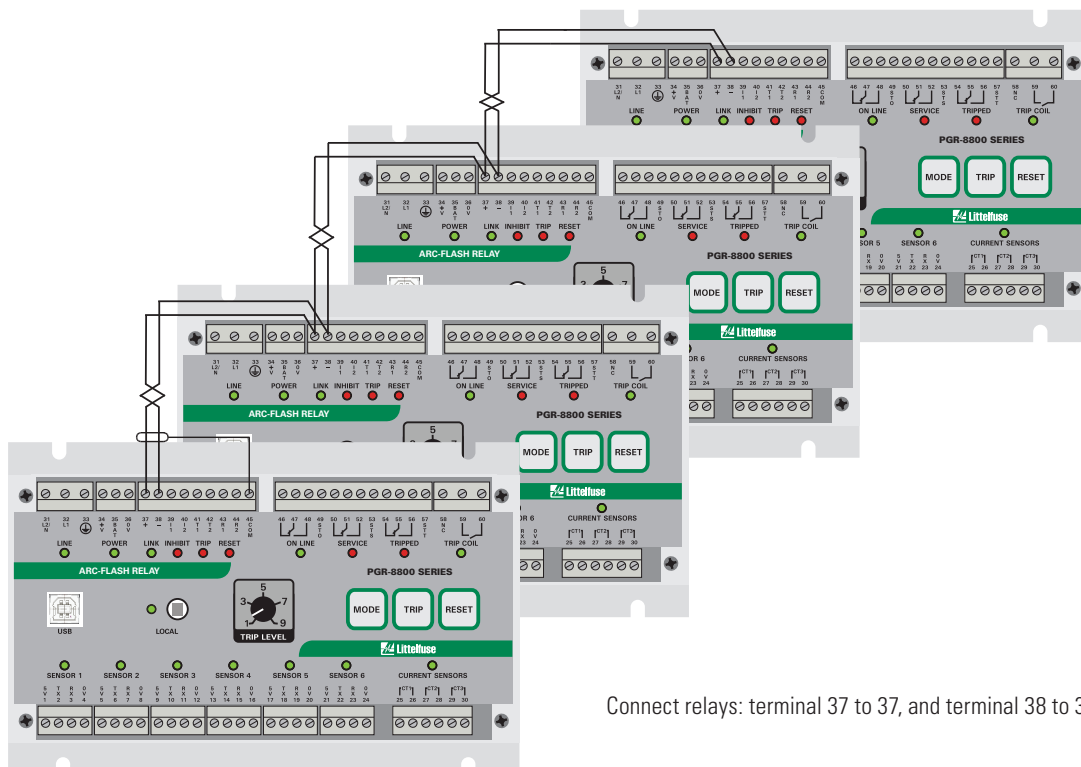

Connect relays: terminal 37 to 37, and terminal 38 to 38.

## APPLICATION GUIDE

### 5 EXAMPLES

#### 5.1 Light Detection Only

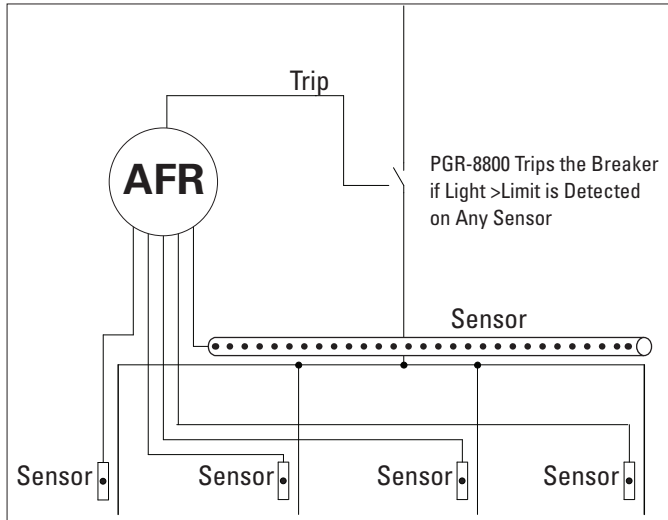

#### 5.2 Light and Current Detection

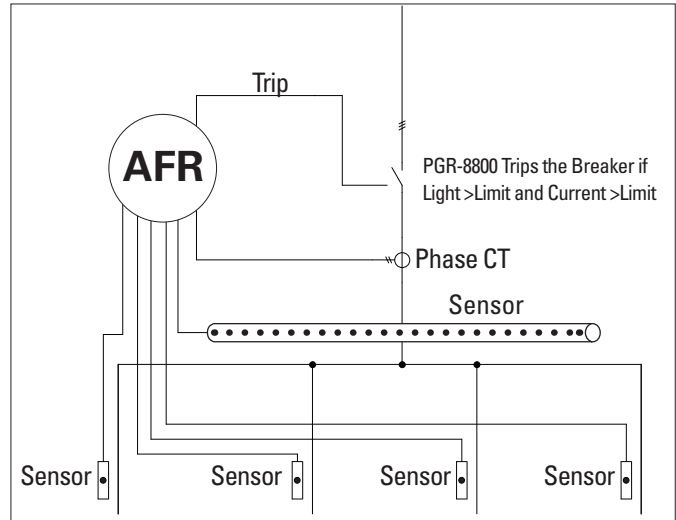

#### 5.3 Tripping of an upstream circuit breaker in case of clearing failures on the local circuit breaker

In case tripping of a local circuit breaker fails (clearing failure), the PGR-8800 can be configured to trip an upstream circuit breaker. For this application it is necessary to detect the position of the local circuit breaker (whether it is open or closed). This can be done either by detection of a circuit breaker feedback signal from an auxiliary contact of the local circuit breaker, or by current detection (see sections 5.3.1 and 5.3.2).

In smaller systems both the local and the upstream circuit breaker can be tripped by the same PGR-8800. This is possible through re-configuration of the trip relay output. Note however that there is no cable monitoring on the trip relay output.

- Only one PGR-8800 is required for tripping both local and upstream circuit breaker.

In more complex systems it can be an advantage to use one PGR-8800 for the local circuit breaker and another one for the upstream circuit breaker. Note that the maximum length of the link interface is 10m.

- The switchboard section between local circuit breaker and upstream circuit breaker can be monitored as well
- Independent trip voltages possible for local and upstream circuit breaker
- The entire trip path to both local and upstream circuit breakers can be cable monitored

##### 5.3.1 Detection of clearing failure through a circuit breaker feedback contact

This is the simplest application for detection of a clearing failure. The same PGR-8800 will trip both local and upstream circuit breakers. No additional hardware is needed for detection of clearing failure.

The PGR-8800 detects the position of the local circuit breaker through an auxiliary contact of the local circuit breaker. In case the local circuit breaker does not open after the trip signal has been sent, the PGR-8800 will send a trip signal to the upstream circuit breaker. This upstream circuit breaker trip signal comes from the trip relay output of the PGR-8800 and includes a programmable time delay, in order to give the main trip circuit time to clear the fault first.

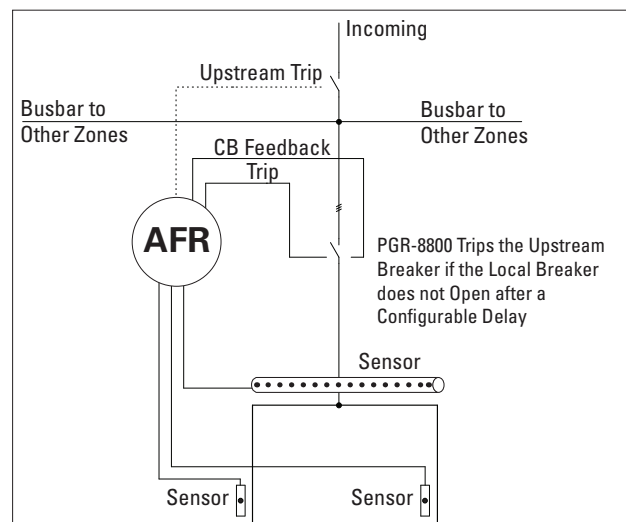

## APPLICATION GUIDE

### 5.3.2 Detection of clearing failure through current measurement

The same PGR-8800 will trip both local and upstream circuit breaker. The PGR-8800 will detect the current through current transformers. If it still detects a current after the local circuit breaker has been tripped, the unit will send a trip signal to the upstream circuit breaker.

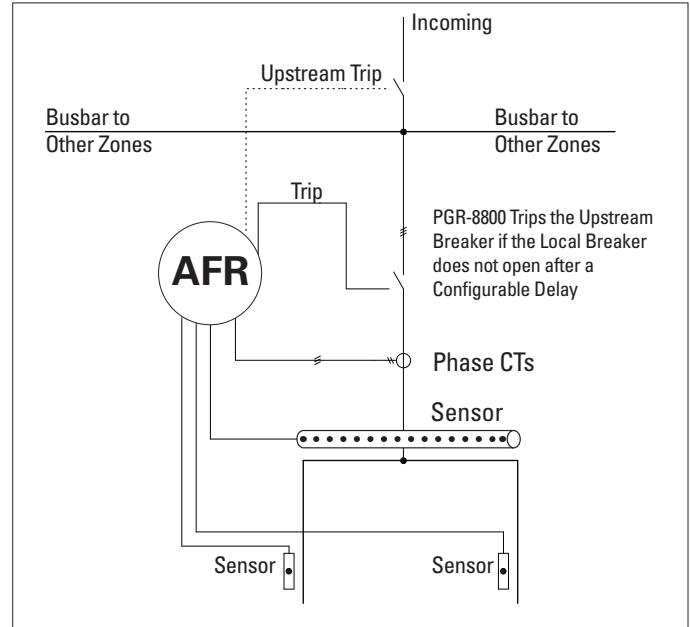

### 5.3.3 Tripping of the upstream circuit breaker through link interface

In more complex systems the tripping of the upstream circuit breakers can be done through the link interface.

This application shows two circuit breakers that are being tripped by separate PGR-8800 relays. The PGR-8800 shown on top protects the upper bus bar section and trips the incoming feeder circuit breaker in case of an arc in the top section. The unit in the lower section protects the lower section of the switchboard. If an arc flash occurs in the lower section the unit will trip the local circuit breaker. If this fails, the trip information will be shared with the upstream unit, which will then trip the upstream circuit breaker.

Circuit breaker feedback for the downstream circuit breaker can be detected by an auxiliary contact of the downstream circuit breaker or current detection.

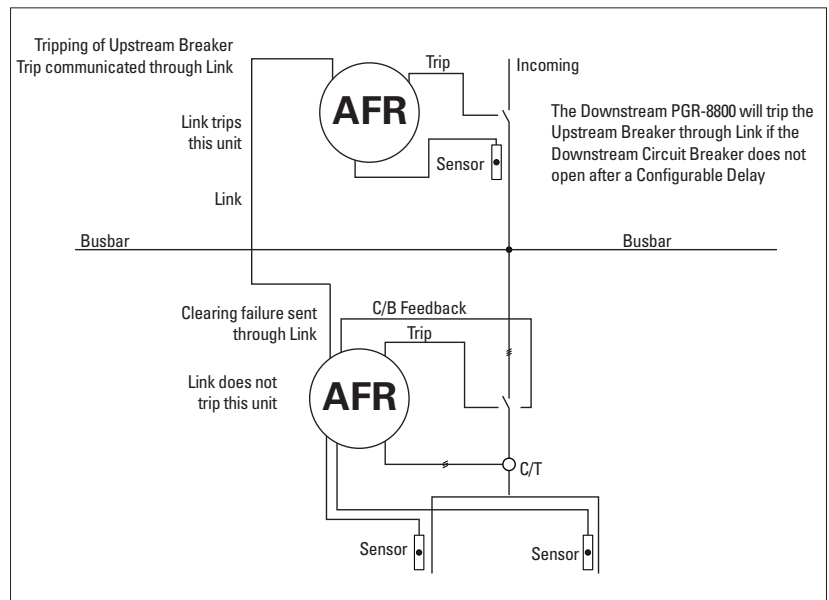



## APPLICATION GUIDE

### 5.4 Simultaneous tripping of an incoming feeder and a tie circuit breaker (main-tie-main application)

In case a switchboard is divided into separate sections by tie circuit breakers and fed by more than one incoming feeder, it can be an advantage to disconnect only the switchboard section where the arc is present, while leaving the other sections online. In this case it is not enough to trip the incoming feeder alone. The tie circuit breakers must be tripped as well, in order to isolate the section with the arc fault from the rest of the system.

#### 5.4.1 Zone detection and isolation using PGA-1100

The single line diagram shows an application with two incoming feeders and a tie circuit breaker. All sensors are downstream of the circuit breakers. If an arc is detected on either side of the tie circuit breaker the respective feeder circuit breaker and the tie circuit breaker will be tripped.

This application is based on PGR-8800 default configuration, meaning no programming is needed. The application shows the use of the PGA-1100 unit for tripping the same circuit breaker from multiple units. The purpose of the PGA-1100 is to isolate the trip signal of the PGR-8800 of one bus bar section from the incoming feeder of the other section, so that an arc flash in section 1 would only cause disconnection of section 1, while section 2 would remain alive.

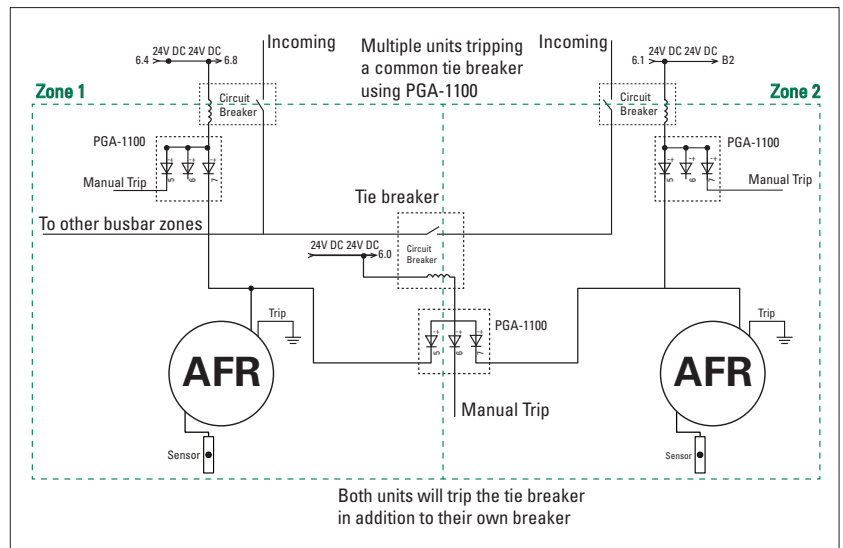

#### 5.4.2 Zone detection and isolation using the link connection

This application is a larger version of the system described in the previous section. The tie circuit breaker divides the switchboard into two parts. An arc in any compartment is to trip the incoming feeder of the respective switchboard part and the tie circuit breaker, so the second half of the switchboard can continue functioning.

Each switchboard section divided by the tie circuit breaker has at least two PGR-8800 Arc Flash Relays (depending on required number of sensors up to four PGR-8800 units may be used for each section).

The two PGR-8800 units in each switchboard section work as one system, with one of the PGR-8800 unit tripping the incoming feeder, and the other unit for tripping the tie circuit breaker. With this application the trip voltages of incoming feeder circuit breaker and tie circuit breaker can be independent from each other, making the installation more flexible and adaptable to match different types of shunt trip coils.

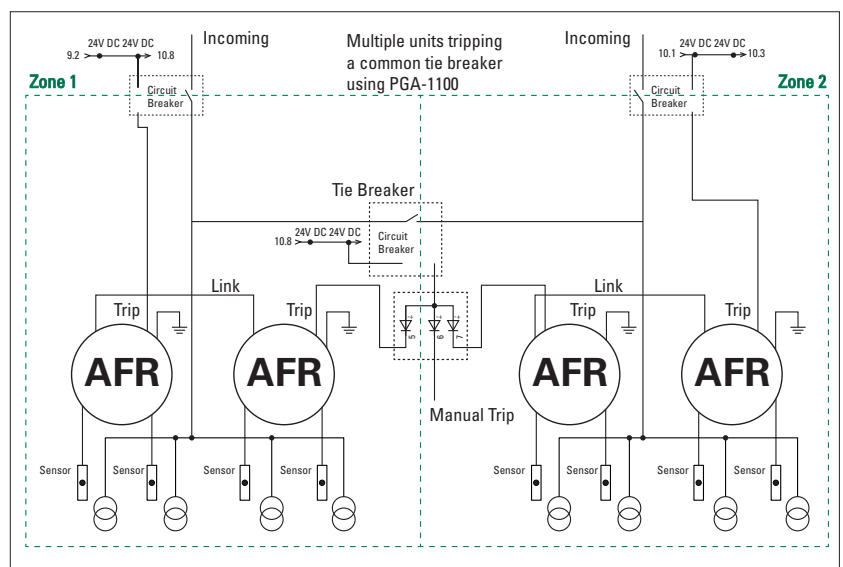

## APPLICATION GUIDE

### APPENDIX A: SUPPORTING MATERIALS

Littelfuse provides many supporting materials in digital format for the function and installation of the PGR-8800 Arc Flash Relay.

**Manual**

**Datasheet**

**Guideform Specifications**

**Workbook for Estimating Arc-Flash Incident Energy Reduction**

**FAQ Booklet**

**White Paper**

**Brochure**

**Videos**

These can be found at: [Littelfuse.com/ArcFlash](http://Littelfuse.com/ArcFlash)

### PGR-8800 COMMISSIONING INFORMATION

General Installation Settings	Default Setting	User Setting	Comments
Date Installed			
Operator			
Front Panel Trip Level (1-9)	9		
Comment 1			
Comment 2			

Setpoint	Default Setting	User Setting	Comments
<b>General</b>			
<b>System Name</b>			
Description of this unit	PGR-8800 Arc-Flash Relay		
<b>Date and Time</b>			
Synchronize to PC Clock	No		
<b>Optical Sensors</b>			
<b>Common Settings</b>			
Arc detection time before tripping	1ms		
LED flashes green when above	75% of trip level		
<b>Sensor 1</b>			
Sensor description	Sensor 1		
Ignore sensor check errors	No		
Change configuration	No change		
<b>Sensor 2</b>			
Sensor description	Sensor 2		
Ignore sensor check errors	No		
Change configuration	No change		
<b>Sensor 3</b>			
Sensor description	Sensor 3		
Ignore sensor check errors	No		
Change configuration	No change		
<b>Sensor 4</b>			
Sensor description	Sensor 4		
Ignore sensor check errors	No		
Change configuration	No change		
<b>Sensor 5</b>			
Sensor description	Sensor 5		
Ignore sensor check errors	No		
Change configuration	No change		

## APPLICATION GUIDE

Setpoint	Default Setting	User Setting	Comments
<b>Sensor 6</b>			
Sensor description	Sensor 6		
Ignore sensor check errors	No		
Change configuration	No change		
<b>Local Sensor</b>			
Sensor description	Local sensor		
Local sensor causes trip	No		
<b>Current Sensors</b>			
<b>Setup</b>			
Rated nominal load current	100A RMS on CT primary		
CT transformation ratio	100 to 5		
Current sensor mode	AC		
Enable current inhibit	No		
Trip on Overcurrent 1	No		
Trip on Overcurrent 2	No		
<b>Digital Inputs</b>			
<b>Inhibit Inputs</b>			
Function	Inhibit when low (switch closed)		
<b>Trip Inputs</b>			
Main function	Trip input		
Function	Trip the output when low (switch closed)		
Trip on this input can be inhibited	No		
<b>Reset Inputs</b>			
Function	Reset when low (switch closed)		
<b>Outputs</b>			
<b>Trip Coil Output</b>			
Circuit breaker type	Shunt coil (opens when powered)		
CB pulse time	2s		
Trip the CB in all modes, including Service	No		
Report an error if trip coil is not detected	Yes		
<b>Coordinated Tripping</b>			
Detect clearing failure by trip input	No		
Detect clearing failure by current	No		
<b>Service Output</b>			
Service output function	Indicate Service mode		
<b>Tripped Output</b>			
Tripped output function	Indicate that the unit tripped		
<b>Communications</b>			
<b>Link Interface</b>			
Is used for	Nothing		
<b>Advanced</b>			
<b>Logging</b>			
Enable data logging	No		
Enable waveform capture (beta)	No		
<b>Internal Drives</b>			
Reset configuration drive to factory default	No		
Reset log drive to factory default	No		
<b>Configuration</b>			
Reset configuration to factory defaults	No		

**For more information, visit  
[Littelfuse.com/ArcFlash](http://Littelfuse.com/ArcFlash)**

Additional technical information and application data for Littelfuse protection relays, generator and engine controls, fuses and other circuit protection and safety products can be found on **Littelfuse.com**. For questions, contact our Technical Support Group (**800-832-3873**). Specifications, descriptions and illustrative material in this literature are as accurate as known at the time of publication, but are subject to changes without notice. All data was compiled from public information available from manufacturers' manuals and datasheets.