

PART NO.
GDB61753Z

LTR	DATE	REVISION	CHK	APD
A	4/17/18	519180GCP - RELEASE MRY		

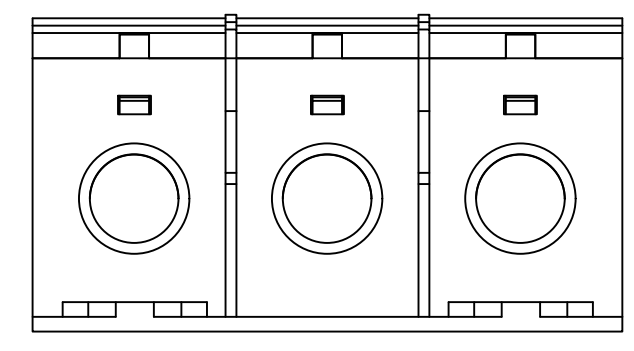
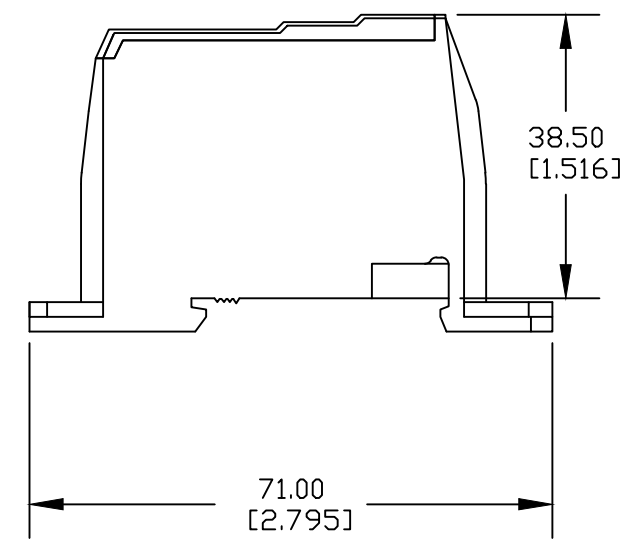
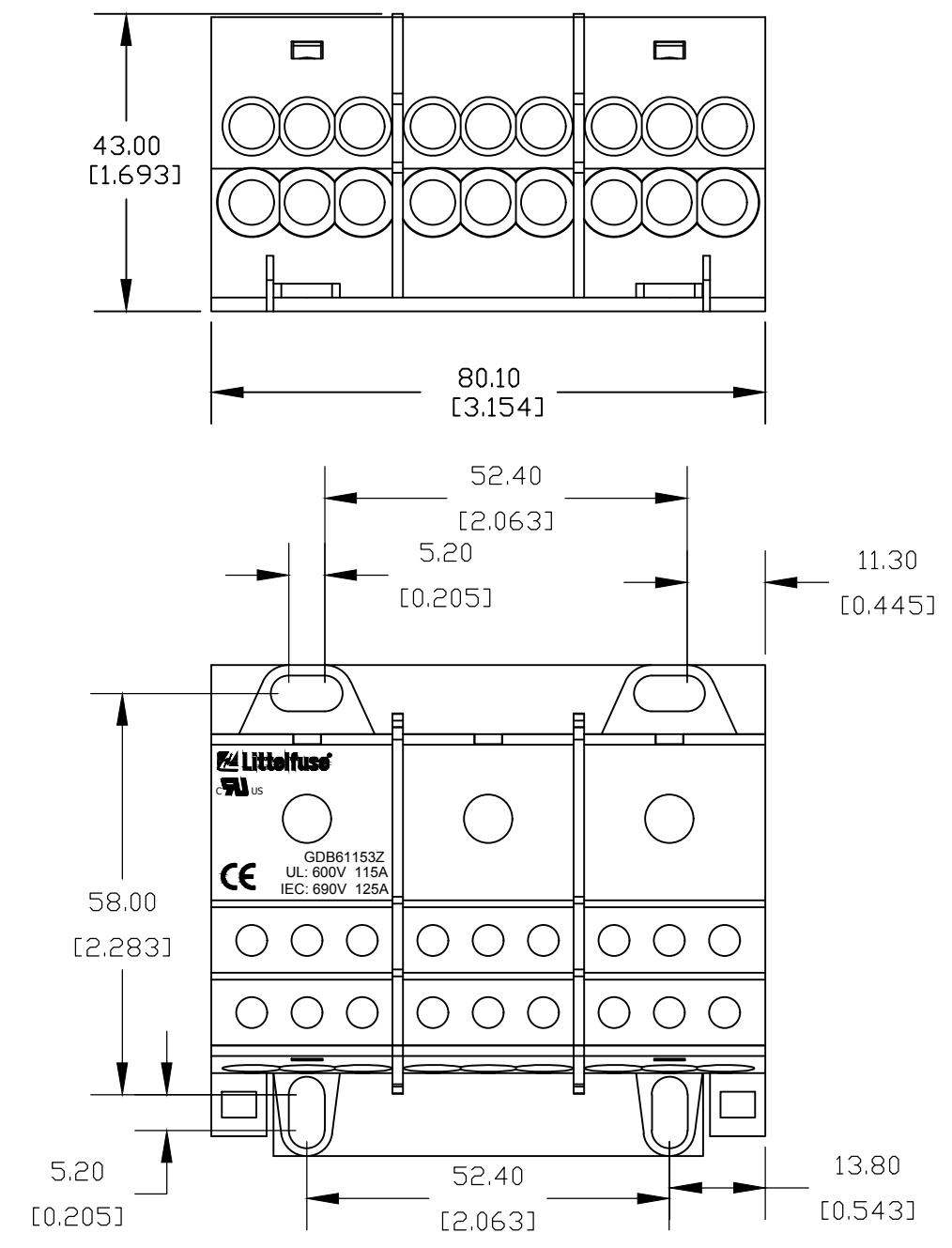

- NOTES:
1. AGENCY INFORMATION:
UL FILE NO. E309688
 2. MATERIALS:
INSULATOR-THERMOPLASTIC
CONNECTOR-BRASS
 3. TERMINATION:
LINE: 8AWG-2/0
LOAD: 4-14 AWG
 4. RATINGS:
600V
MAXIMUM AMP PER POLE-175A
 5. TORQUE:
LINE: 35.5 IN-LB
LOAD: 17.5 IN-LB

UNLESS OTHERWISE SPECIFIED, DIMENSIONS DO NOT INCLUDE PLATING.			
●	DENOTES CRITICAL CHARACTERISTICS.		
CPK	DENOTES CPK DIMENSIONS,-MINIMUM CPK VALUE		
(ST)	DENOTES A CHARACTERISTIC THAT PROVIDES AN INDICATION OF PROCESS PERFORMANCE. PROCEDURE FOR MEASUREMENT AND TRACKING TO BE DEFINED IN LITTELFUSE INSPECTION INSTRUCTIONS.		
CP	DENOTES CP DIMENSIONS,-MINIMUM CP VALUE MUST BE WITHIN THE DIMENSIONAL LIMITATIONS SHOWN ON DRAWING AND INITIALLY LOCATED TO ALLOW FOR MAXIMUM TOOL LIFE.		
COPIES TO			
1	9	18	FINISH
2	10	19	
3	12	20	SCALE
4	13	21	
5	14	23	SUPER DR
6	15	33	
7	16	43	RAW STK WT
8	17	53	
TITLE			
GDB6175 SERIES DISTRIBUTION BLOCK OUTLINE			
Littelfuse CHICAGO, ILLINOIS 60631		REVISION A	DRWG. NO. DL-GDB6175
			FINAL

CAD GENERATED DRAWING - NO PENCIL CHANGES ALLOWED