

PART NUMBER
LPBC1441
LPBC1442
LPBC1443
LPBC1444

REVISION		DESCRIPTION
REV	DATE	
A	12/11/17	518515GCP - RELEASE PER EM2988 MRY

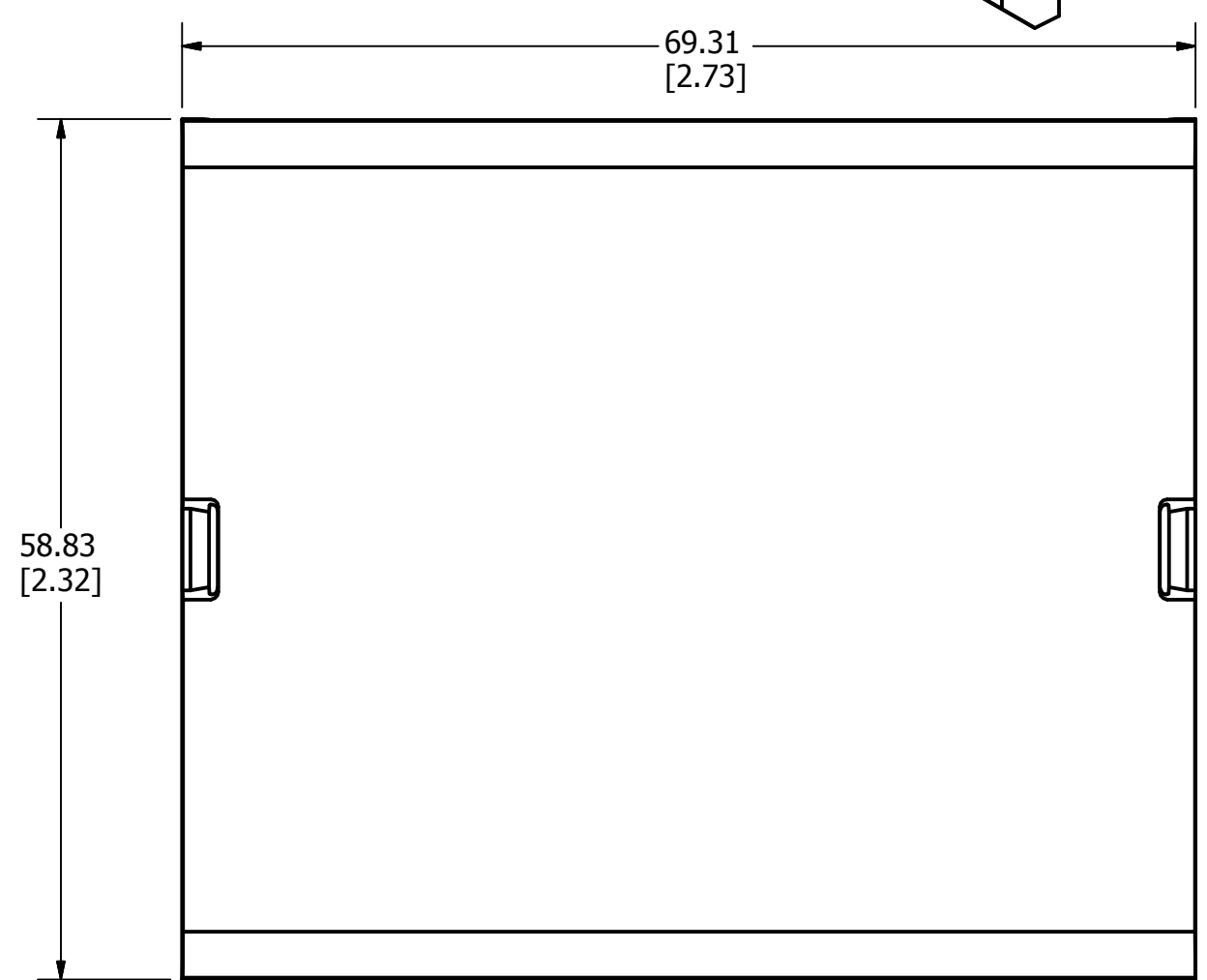
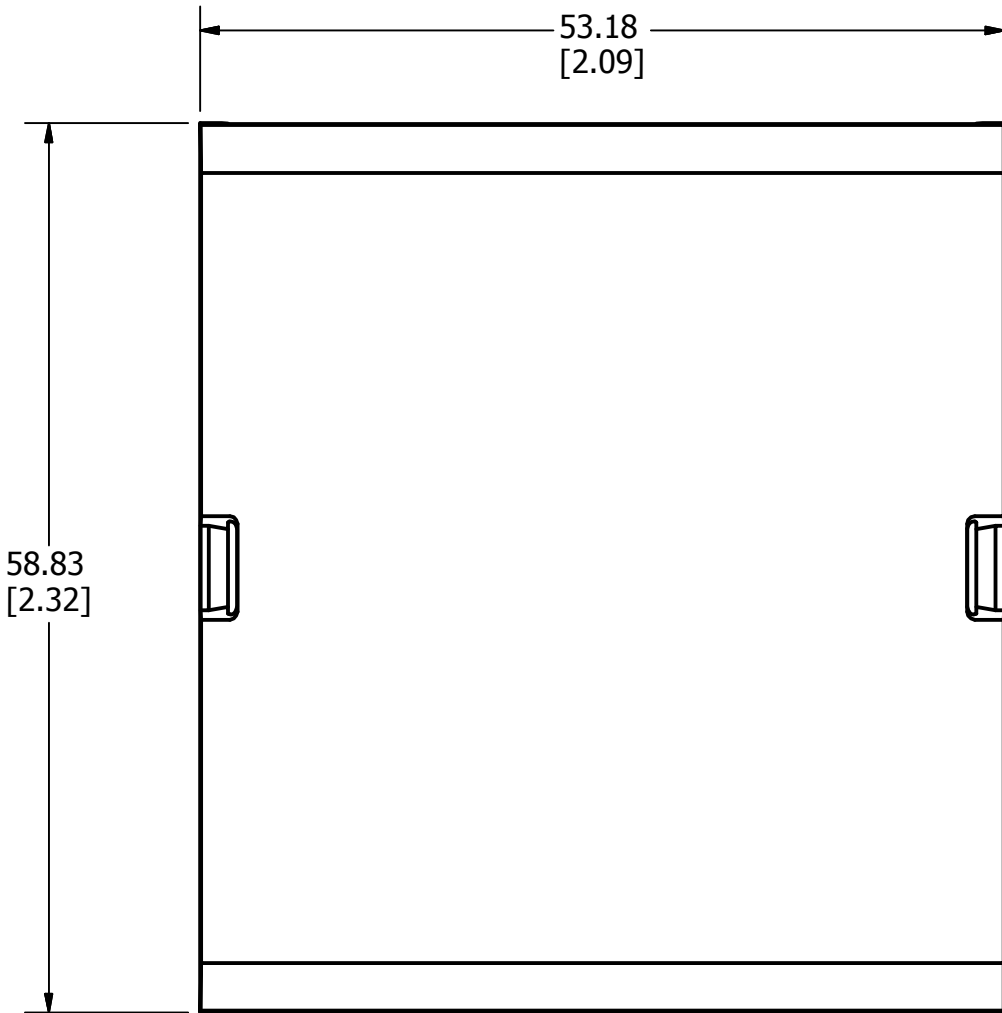
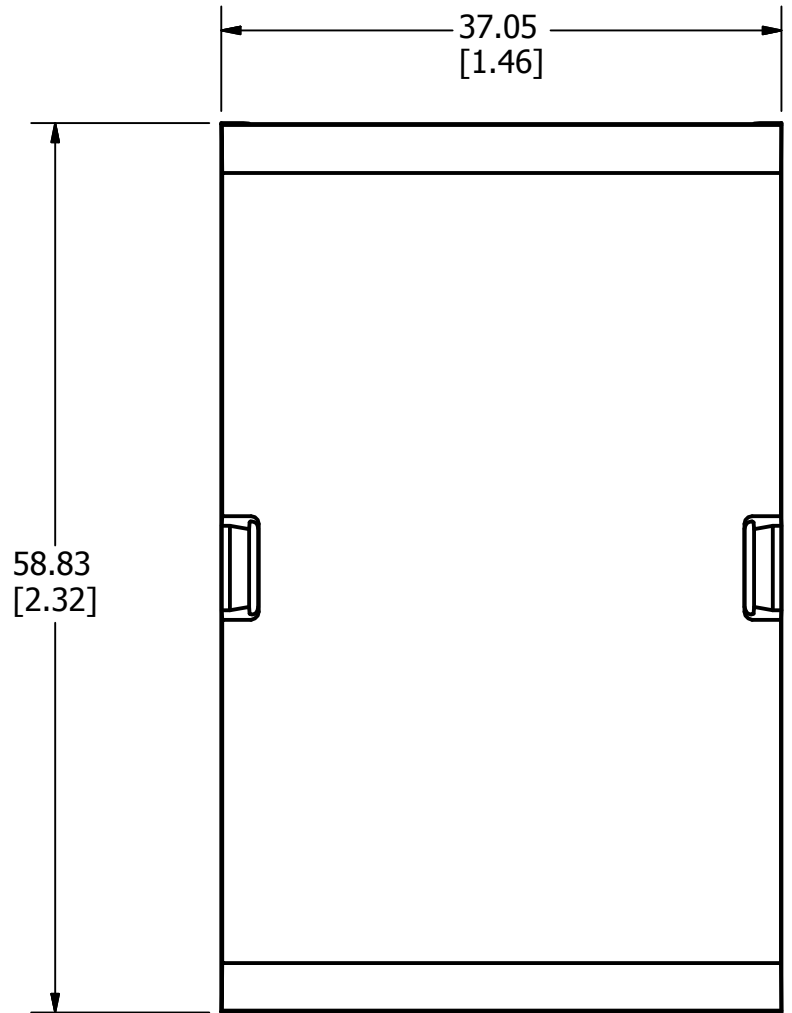
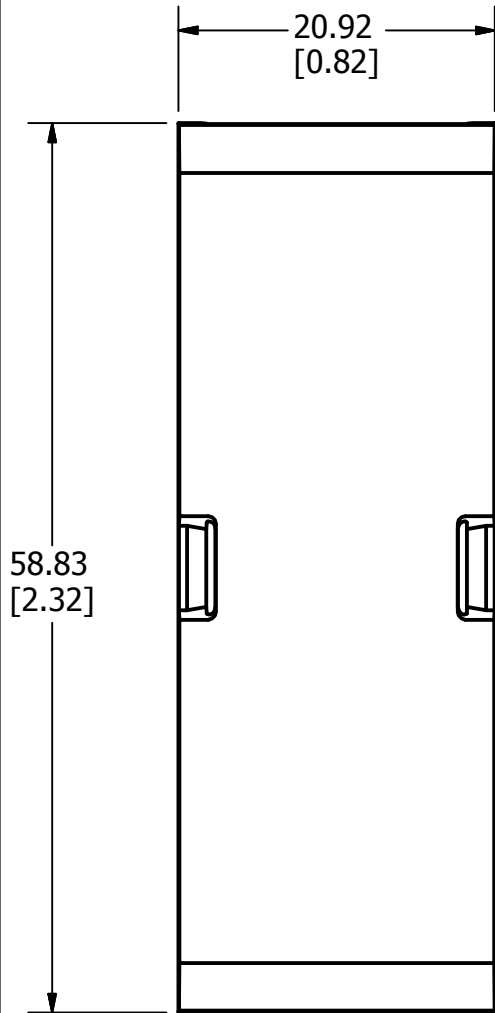
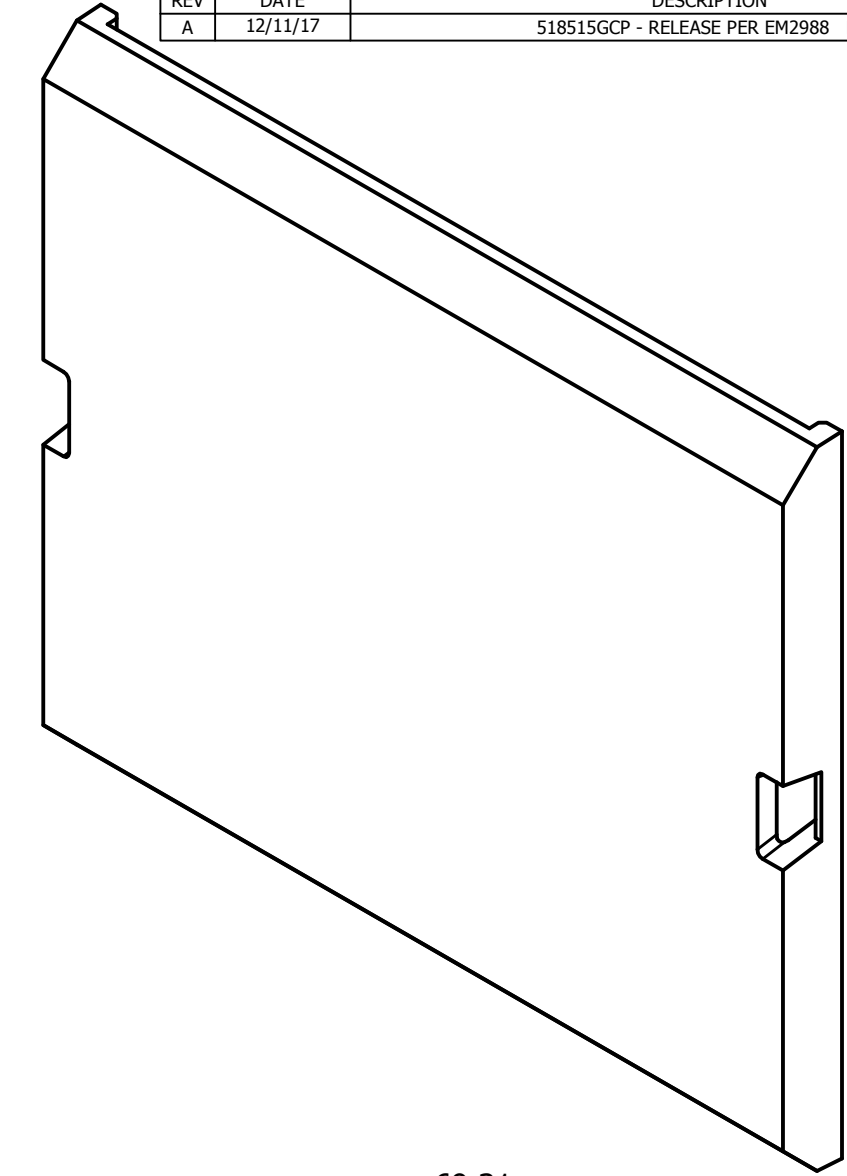
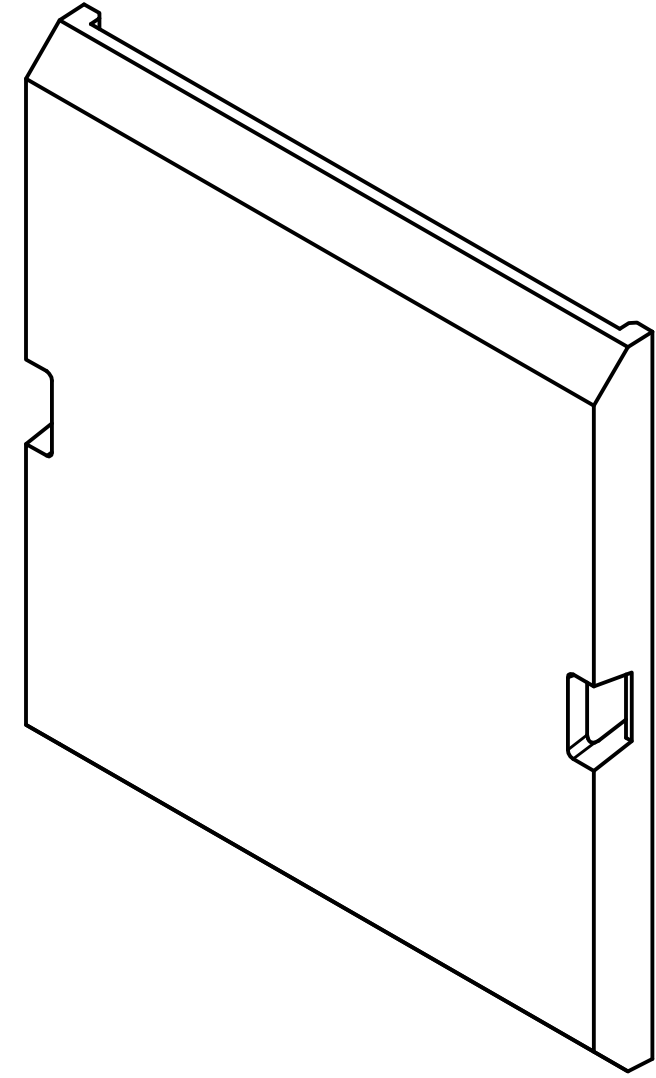
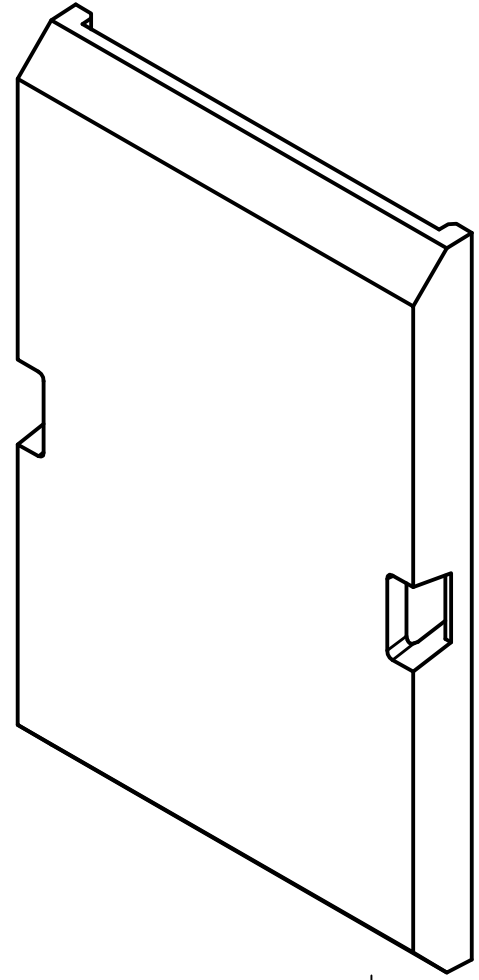
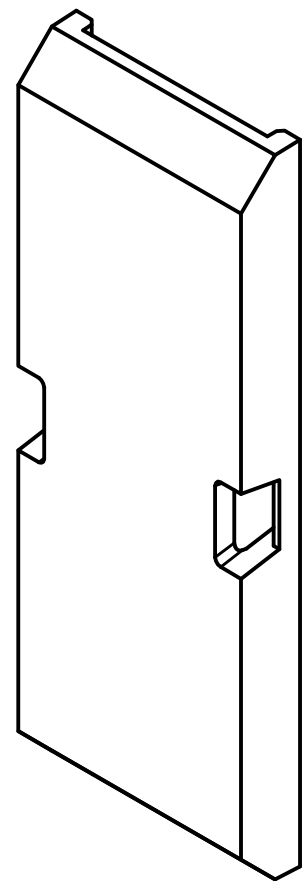

LPBC1441

LPBC1442

LPBC1443

LPBC1444

●	DENOTES CRITICAL CHARACTERISTICS.
CPK	DENOTES CPK DIMENSIONS, -MINIMUM CPK VALUE
(ST)	DENOTES A CHARACTERISTIC THAT PROVIDES AN INDICATION OF PROCESS PERFORMANCE. PROCEDURE FOR MEASUREMENT AND TRACKING TO BE DEFINED IN LITTELFUSE INSPECTION INSTRUCTIONS.
CP	DENOTES CP DIMENSIONS, -MINIMUM CP VALUE. MUST BE WITHIN THE DIMENSIONAL LIMITATIONS SHOWN ON DRAWING AND INITIALLY LOCATED TO ALLOW FOR MAXIMUM TOOL LIFE.

MATL SPEC	FINISH		
DRW MYORK	DATE 10/17/2017	SCALE NTS	FINISH GOOD WT GRAMS/PIECE

UNLESS OTHERWISE SPECIFIED, DIMENSIONS ARE IN MILLIMETERS, DIMENSIONS IN BRACKETS [ ] ARE INCHES DIMENSIONING AND DO NOT INCLUDE PLATING. TOLERANCING TO BE INTERPRETED IN ACCORDANCE WITH ANSI Y14.5M-1994



TITLE LPBC144 SERIES OUTLINE

 CHICAGO, ILLINOIS 60631	REVISION	DRWG NO.	SHEET 1 OF 1
	A	OL-LPBC144	