

REVISION		
REV	DATE	DESCRIPTION
A	11/8/18	520127GCP - RELEASE MRY

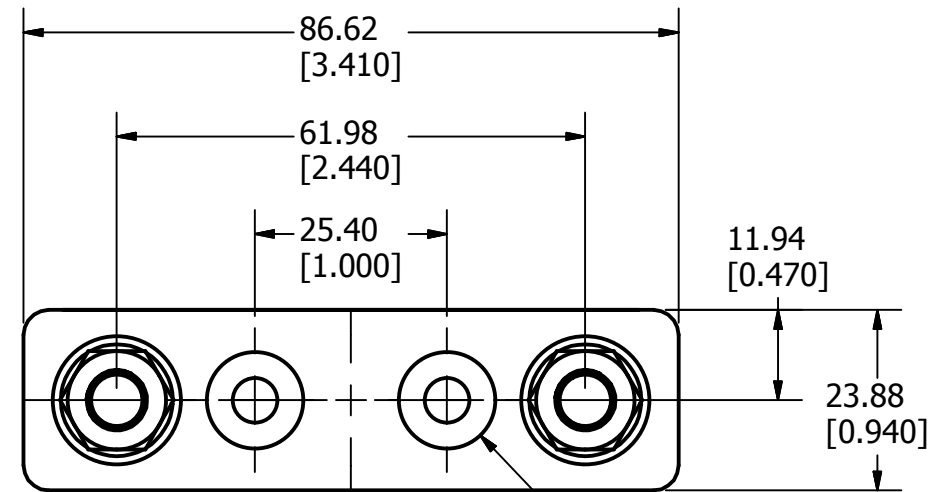

2x $\varnothing 5.84$ THRU
 $\surd \varnothing 12.70 \times 82.0^\circ$
 [2x $\varnothing 0.230$ THRU]
 $\surd \varnothing 0.500 \times 82.0^\circ$

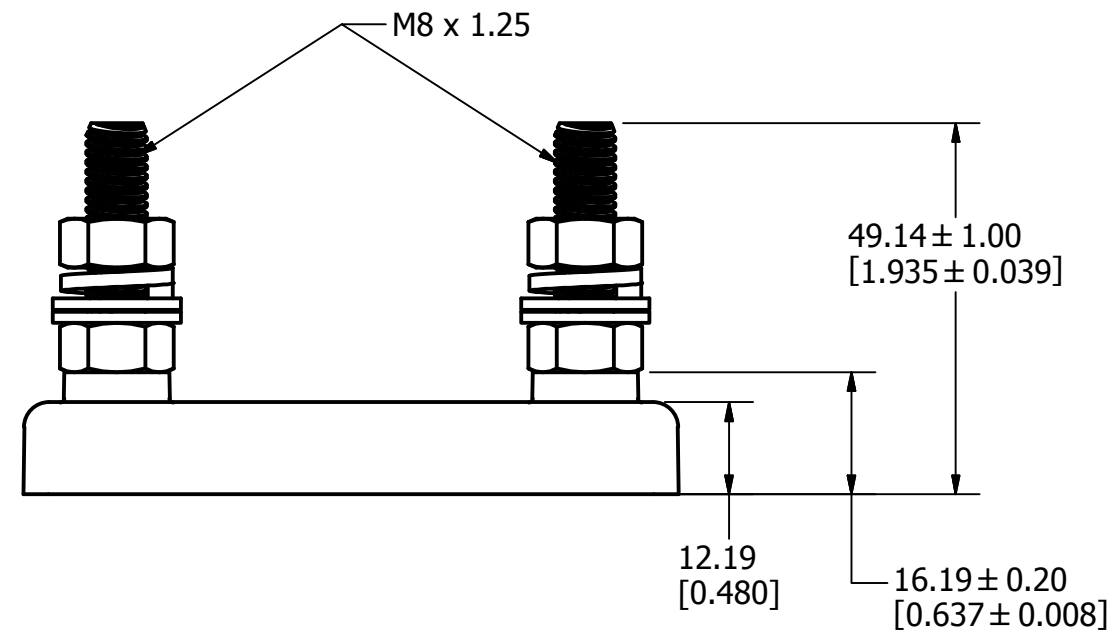

TORQUE: BASE: 25 IN-LB
 FUSE: 90 IN-LB
 MOUNTING SCREW: #10 FLAT HEAD

<S>	CRITICAL CHARACTERISTIC FOR PART SAFETY/COMPLIANCE
●	DENOTES CRITICAL CHARACTERISTICS.
CPK	DENOTES CPK DIMENSIONS, -MINIMUM CPK VALUE
Ⓢ	DENOTES A CHARACTERISTIC THAT PROVIDES AN INDICATION OF PROCESS PERFORMANCE. PROCEDURE FOR MEASUREMENT AND TRACKING TO BE DEFINED IN LITTELFUSE INSPECTION INSTRUCTIONS.
CP	DENOTES CP DIMENSIONS, -MINIMUM CP VALUE MUST BE WITHIN THE DIMENSIONAL LIMITATIONS SHOWN ON DRAWING AND INITIALLY LOCATED TO ALLOW FOR MAXIMUM TOOL LIFE.

B

MATL SPEC		FINISH	
DRW myork	DATE 11/1/2018	SCALE NTS	FINISH GOOD WT GRAMS/PIECE

UNLESS OTHERWISE SPECIFIED, DIMENSIONS ARE IN MILLIMETERS, DIMENSIONS IN BRACKETS [] ARE INCHES DIMENSIONING AND DO NOT INCLUDE PLATING. TOLERANCING TO BE INTERPRETED IN ACCORDANCE WITH ANSI Y14.5M-1994

3RD ANGLE PROJECTION	TOLERANCE UNLESS OTHERWISE SPECIFIED ONE PLACE DEC $\pm .25$ [.01] FRACTION \pm TWO PLACE DEC $\pm .100$ [.004] ANGULAR $\pm 1^\circ$
----------------------	---

TITLE	LFFB003 OUTLINE
-------	-----------------

Littelfuse CHICAGO, ILLINOIS 60631	REVISION A	DRWG NO. OL-LFFB003	SHEET 1 OF 1
--	---------------	------------------------	--------------