

THIS DRAWING AND THE INFORMATION CONTAINED WITHIN IT ARE CONFIDENTIAL AND MAY NOT BE COPIED OR DISCLOSED WITHOUT THE WRITTEN PERMISSION OF LITTELFUSE.

REVISIONS				
ZONE	REV.	DESCRIPTION	DATE	APPROVED
	E	ECA 515922 RELEASE HD RELAY REDESIGN DRAWING	5/24/2016	D.CHENG
	F	PER ECO #520075 UPDATE MOUNTING HOLE DIMENSION	10/26/2018	C.MILLER

Specifications	
Maximum Continuous Current (4/0 Input/Output Cable)	300A
Inrush Rating (10 seconds) (4/0 Input/Output Cable)	1500A
Control Circuit Current	7A
Contact Rivet	99.9%Ag
Voltage	18-32V
Mounting Hardware	M5 or #10
Terminal Hardware	3/8"-16
Temperature Range	-50°C to 85°C
Humidity	0-95% RH
Shock	10 G's
Vibration	8 G's
Ingress Rating	IP67/IP69K
Ignition Protection	Meets ISO 8846 & SAE J1171

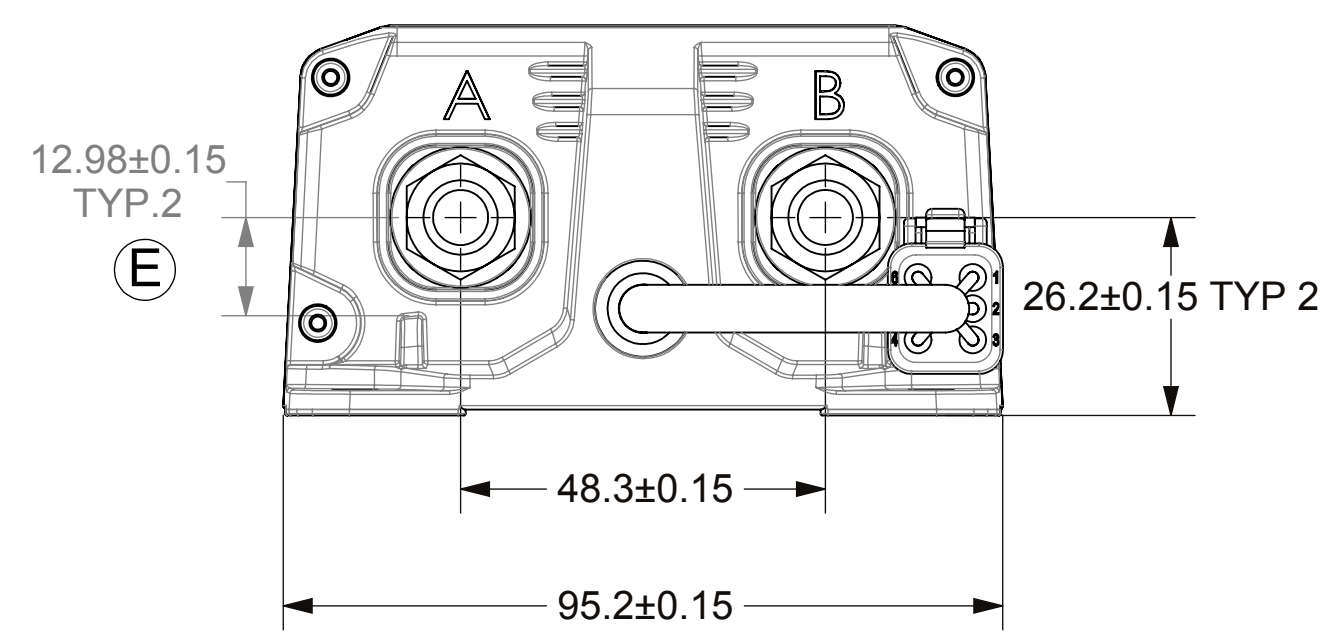
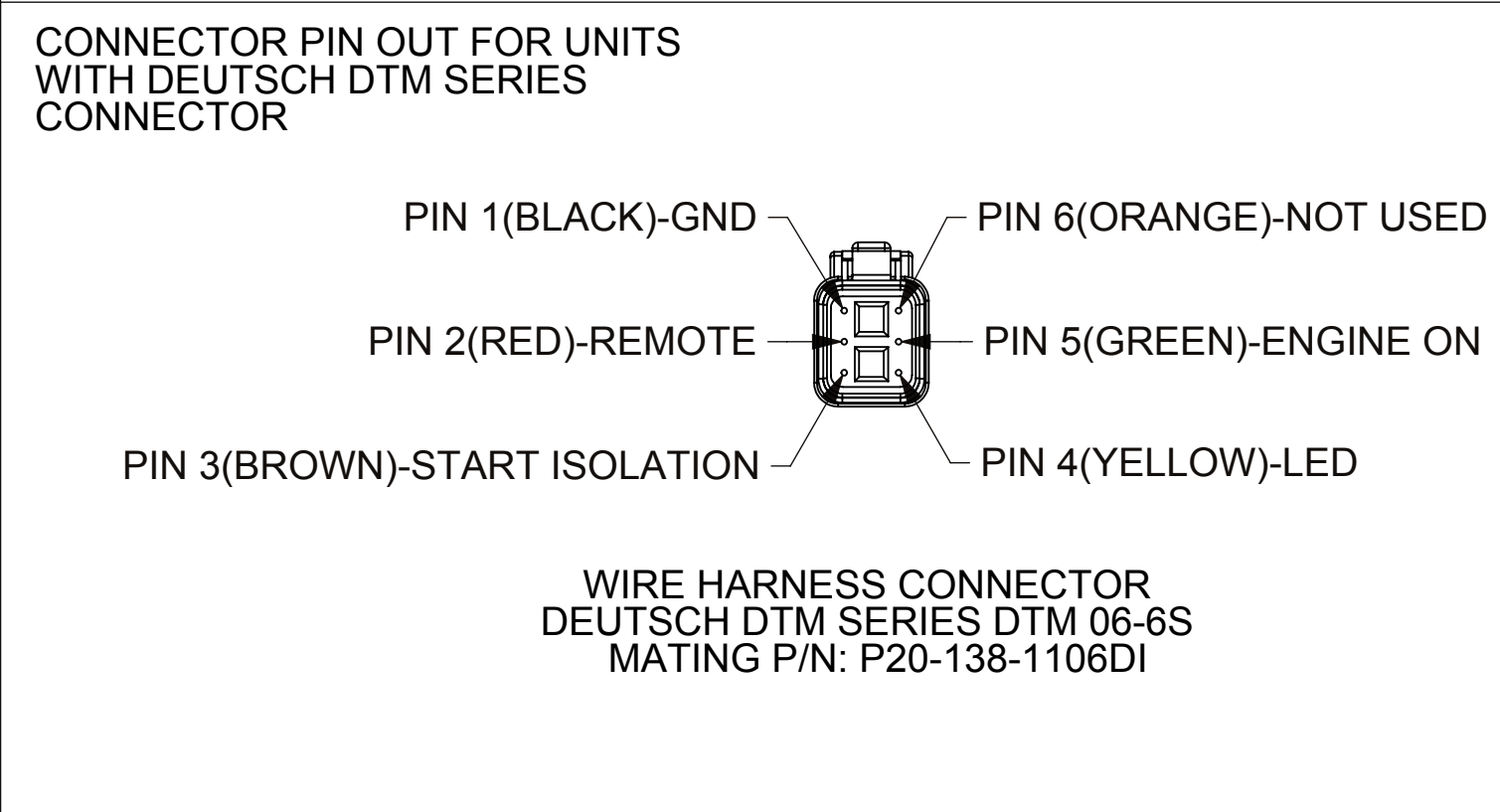
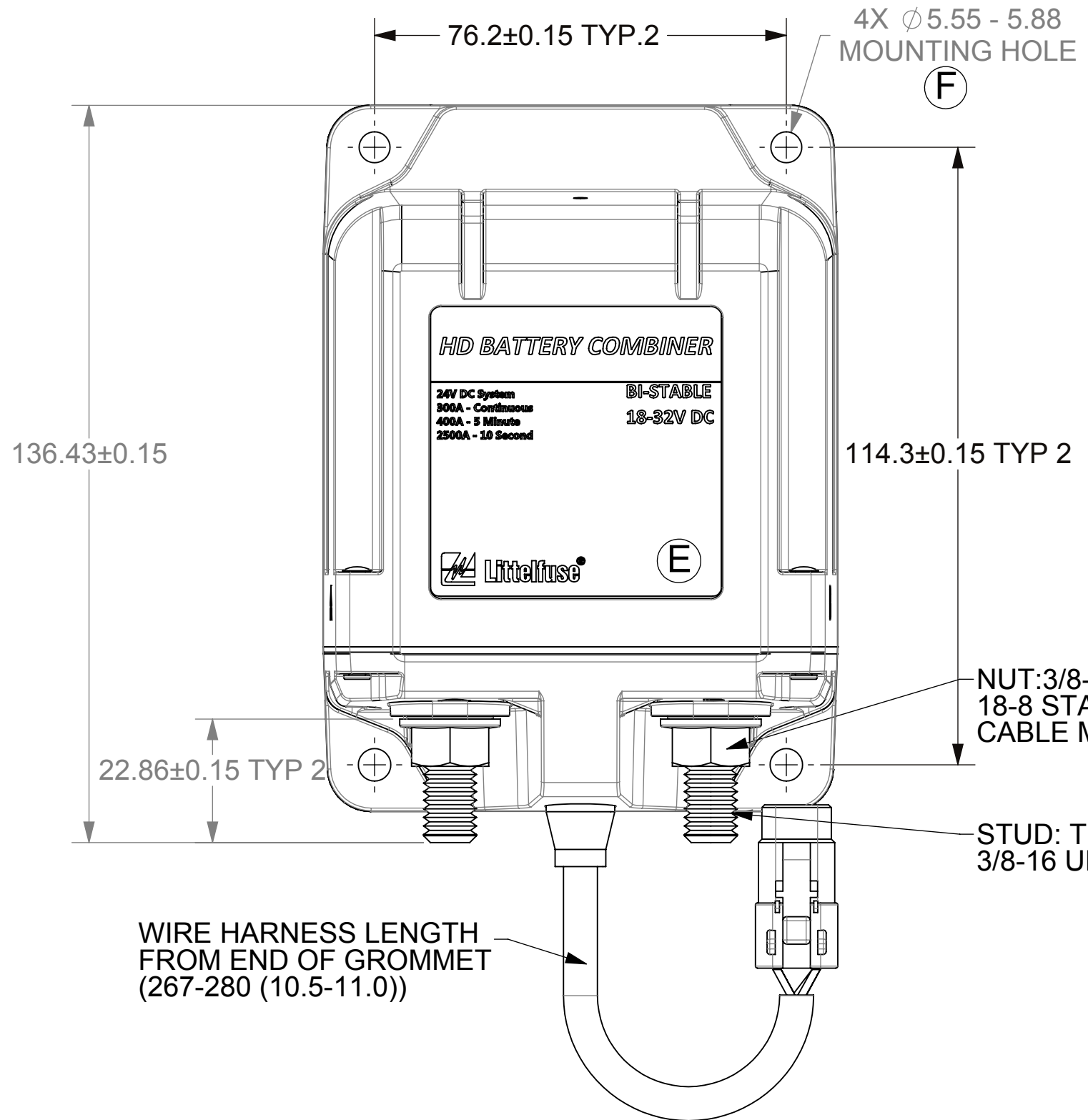
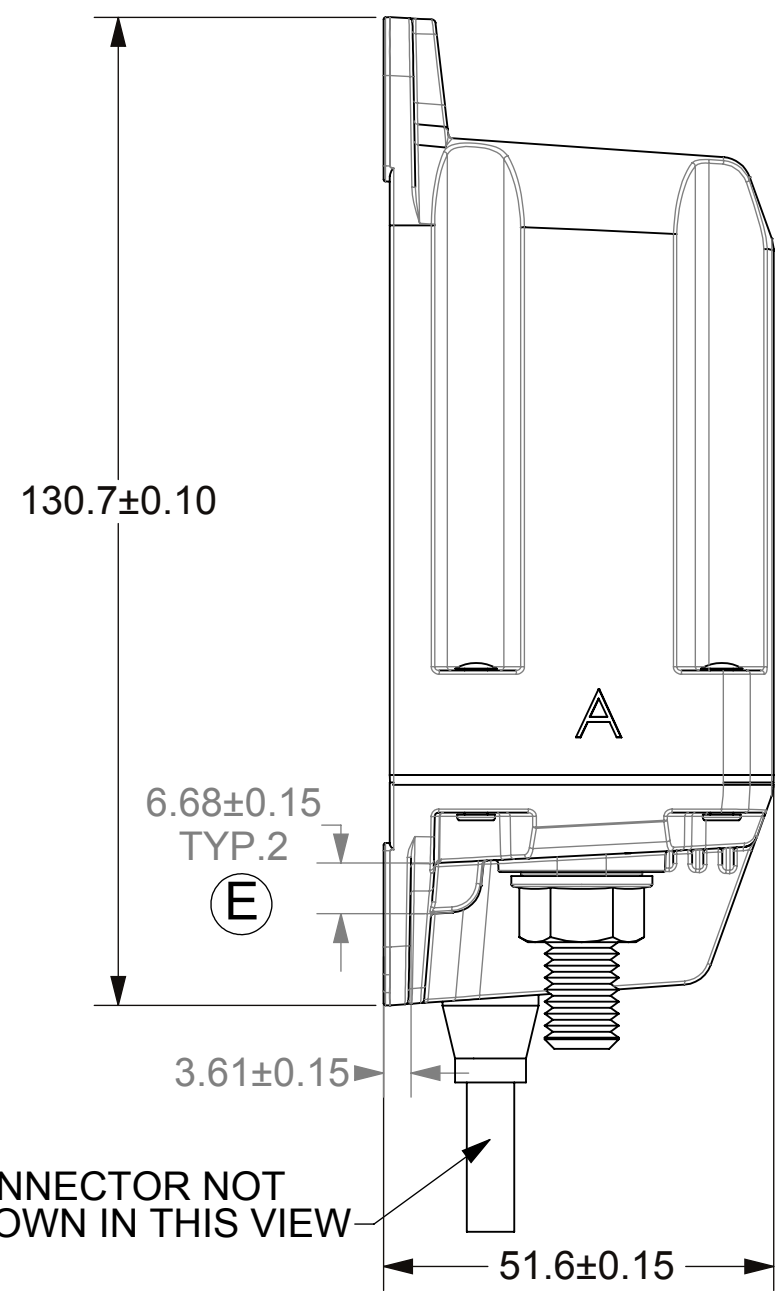
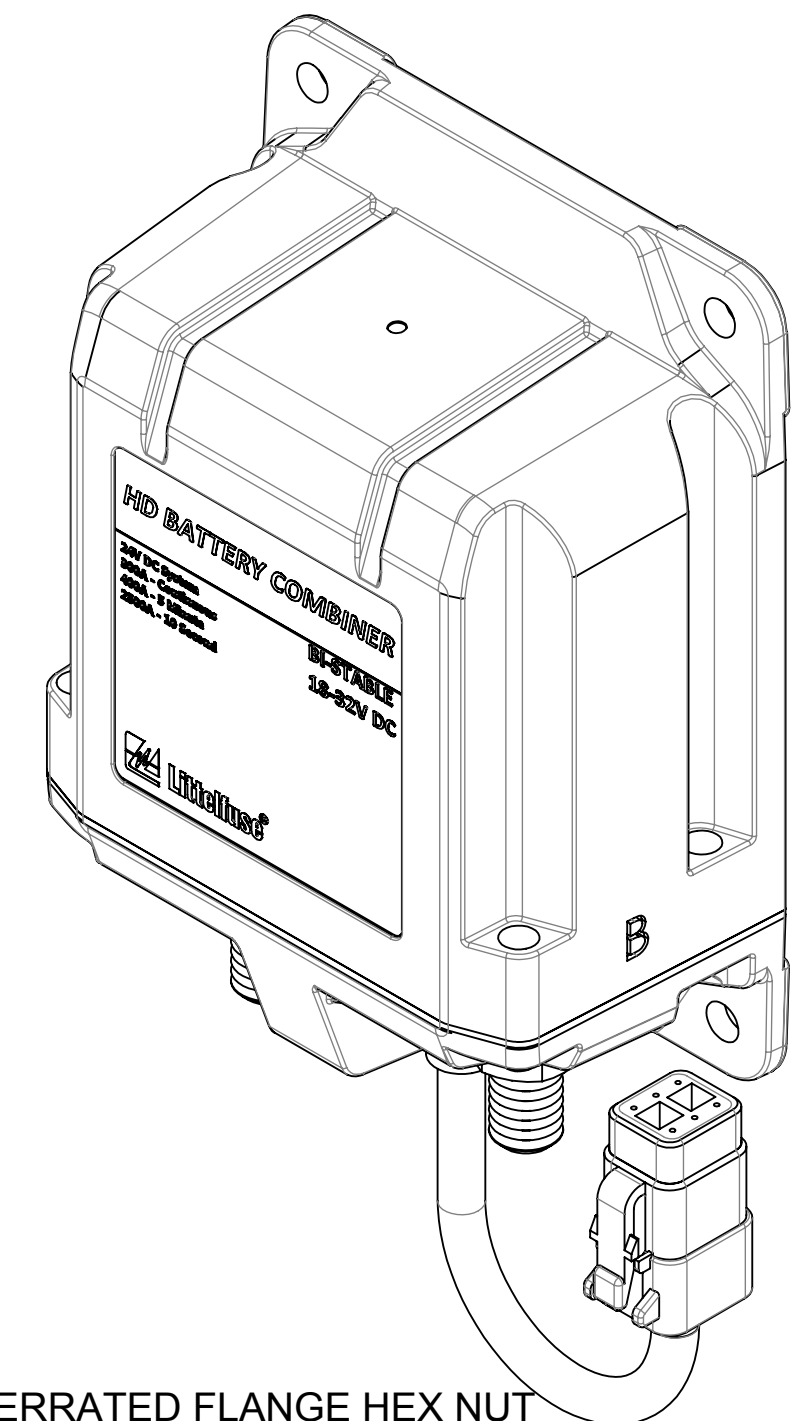
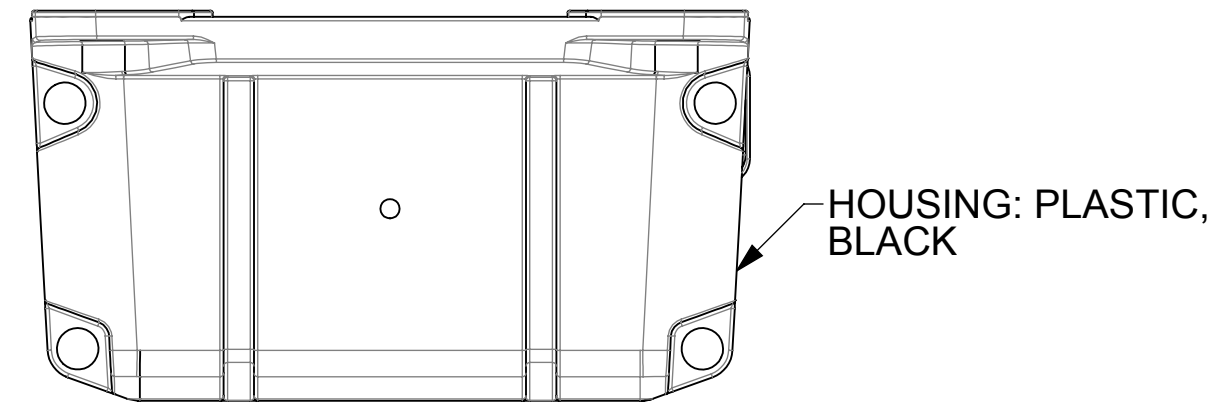

DIMENSIONS ARE SHOWN IN MILLIMETERS. DIMENSIONS AND TOLERANCES ARE DEFINED ACCORDING TO ANSI/ASME Y14.5-1994.	
●	FIT FUNCTION CRITICAL CHARACTERISTICS SYMBOL
<S>	SAFETY/ COMPLIANCE CRITICAL CHARACTERISTICS SYMBOL
CPK	DENOTES CPK DIMENSIONS MINIMUM CPK VALUE
(ST)	DENOTES A CHARACTERISTIC THAT PROVIDES AN INDICATION OF PROCESS PERFORMANCE PROCEDURE FOR MEASUREMENT AND TRACKING TO BE DEFINED IN LITTELFUSE INSPECTION INSTRUCTIONS
CP	DENOTES CP DIMENSIONS - MINIMUM CP VALUE MUST BE WITHIN THE DIMENSIONAL LIMITATIONS SHOWN ON DRAWING AND INITIALLY LOCATED TO ALLOW FOR MAXIMUM TOOL LIFE
DIMENSION: MM TOLERANCES UNLESS OTHERWISE SPECIFIED ONE PLACE DECIMAL ± 0.5 THREE PLACES DECIMAL ± 0.100 TWO PLACES DECIMAL ± 0.20 ANGULAR ± 2°	
DRAWN	D. CHENG 5/24/2016
CHECKED	-
Littelfuse Expertise Applied Answers Delivered	
FORM NO: CVP-PE40-0006 REV A	
THIRD ANGLE PROJECTION	
SIZE	C
DWG. NO.	OL- 880055
REV.	F
DO NOT SCALE DRAWING SCALE 1:1 SHEET 1 OF 1	