

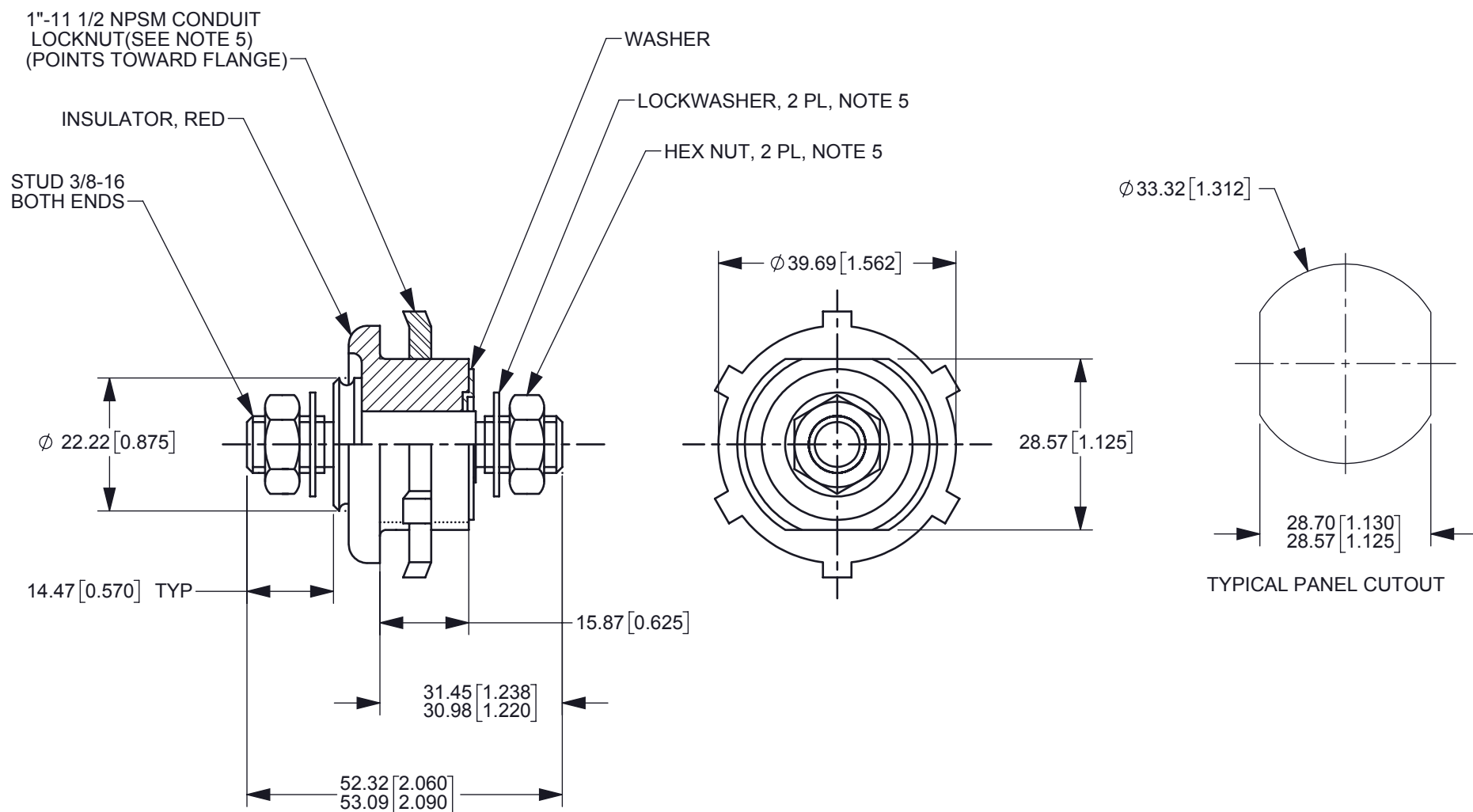

THIS DRAWING AND THE INFORMATION CONTAINED WITHIN IT ARE CONFIDENTIAL AND MAY NOT BE COPIED OR DISCLOSED WITHOUT THE WRITTEN PERMISSION OF LITTELFUSE.

REVISIONS				
ZONE	REV.	DESCRIPTION	DATE	APPROVED
	A	GCF #521133 NEW RELEASED C. MILLER	7/22/19	E.FERNANDEZ

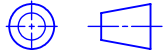

- NOTES:
1. ALL STEEL PARTS PLATED
 2. ALL DIMENSIONS ARE REFERENCE ONLY
 3. MOUNTING THREADS 1"-11 1/2 NPSM-
MOUNTING TORQUE 10.8-13.5 Nm
(8-10 FT LBS) NOT TO EXCEED
13.5 Nm (10 FT LBS)
 4. STUD 3/8"-16 TIGHTENING TORQUE
8.1-10.8 Nm (6-8 FT LBS)
 5. ALL HARDWARE SUPPLIED IN BAG

●		FIT/ FUNCTION CRITICAL CHARACTERISTICS SYMBOL
<S>		SAFETY/ COMPLIANCE CRITICAL CHARACTERISTICS SYMBOL
CPK		DENOTES CPK DIMENSIONS MINIMUM CPK VALUE
ST		DENOTES A CHARACTERISTIC THAT PROVIDES AN INDICATION OF PROCESS PERFORMANCE PROCEDURE FOR MEASUREMENT AND TRACKING TO BE DEFINED IN LITTELFUSE INSPECTION INSTRUCTIONS
CP		DENOTES CP DIMENSIONS. -MINIMUM CP VALUE MUST BE WITHIN THE DIMENSIONAL LIMITATIONS SHOWN ON DRAWING AND INITIALLY LOCATED TO ALLOW FOR MAXIMUM TOOL LIFE
DIMENSION: MM TOLERANCES UNLESS OTHERWISE SPECIFIED ONE PLACE DECIMAL ± 0.5 THREE PLACES DECIMAL ± 0.100 TWO PLACES DECIMAL ± 0.20 ANGULAR ± 2°		
DRAWN	C.MILLER	07/24/19
CHECKED	A.HOANG	07/25/19
	-	-
	-	-
FORM NO: CVP-PE40-0004 REV A		 Expertise Applied Answers Delivered
THIRD ANGLE PROJECTION		
		TITLE
		FEED THRU STUD
SIZE	DWG. NO.	OUTLINE REV.
B	OL-46211-R	A
DO NOT SCALE DRAWING		SHEET 1 OF 1