

8

7

6

5

4

3

2

1

THIS DRAWING AND THE INFORMATION CONTAINED WITHIN IT ARE CONFIDENTIAL AND MAY NOT BE COPIED OR DISCLOSED WITHOUT THE WRITTEN PERMISSION OF LITTELFUSE.

REVISIONS				
ZONE	REV.	DESCRIPTION	DATE	APPROVED
	A	PCO #5300036. INITIAL RELEASE. DSILVA	3/7/2022	L.ARGIL.

ART. NR.	DESCRIPTION	NOTE
178.6192.000_	ADAPTER FKH-HOLDER LEFT	-

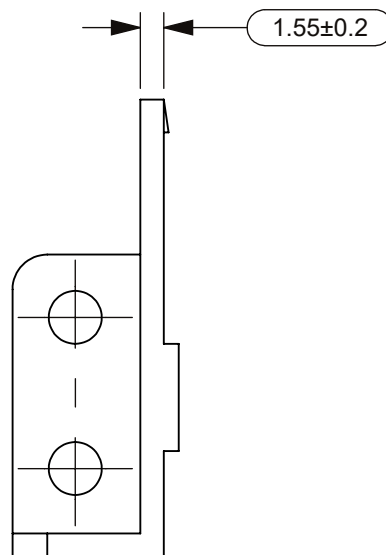
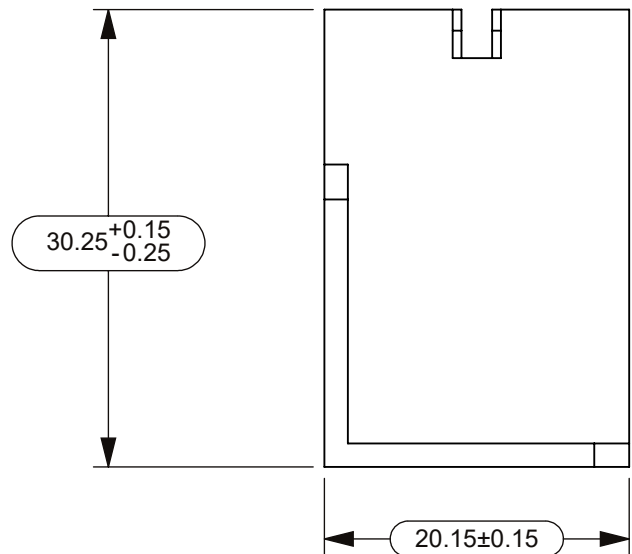
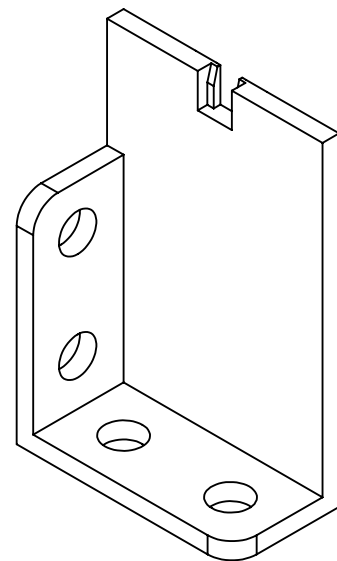
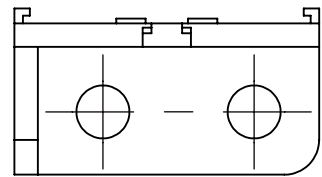



NOTES:
1. MATERIAL: PET, COLOR BLACK

NO.	COMPONENT NO.	COMPONENT NAME	QTY	U	
TOLERANCES UNLESS OTHERWISE SPECIFIED (REF. ISO 2768-FH)					
.5 to 3	>3 to 6	>6 to 30	>30 to 120	>120 to 400	ANGLE
±0.05	±0.05	±0.1	±0.15	±0.2	NONE

DIMENSIONS ARE SHOWN IN MILLIMETERS.
UNLESS OTHERWISE SPECIFIED, DIMENSIONS DO NOT INCLUDE PLATING.

PER CHI-NP020-0008 PROCEDURE	SYMBOL	DESCRIPTION
	●	FIT/ FUNCTION CRITICAL CHARACTERISTICS
	<S>	SAFETY/ COMPLIANCE CRITICAL CHARACTERISTICS SYMBOL
	CPK	DENOTES CPK DIMENSIONS MINIMUM CPK VALUE
	ST	DENOTES A CHARACTERISTIC THAT PROVIDES AN INDICATION OF PROCESS PERFORMANCE. PROCEDURE FOR MEASUREMENT AND TRACKING TO BE DEFINED IN LITTELFUSE INSPECTION INSTRUCTIONS
	CP	DENOTES CP DIMENSIONS. -MINIMUM CP VALUE MUST BE WITHIN THE DIMENSIONAL LIMITATIONS SHOWN ON DRAWING AND INITIALLY LOCATED TO ALLOW FOR MAXIMUM TOOL LIFE

NAME	DATE	 Expertise Applied Answers Delivered
DRAWN DSILVA	1/14/2022	
CHECKED -	-	
-	-	
FORM NO: CVP-PE40-0003 REV B		TITLE ADAPTER FOR FKH-HOLDER LEFT
THIRD ANGLE PROJECTION		
		SCALE B OUTLINE
DO NOT SCALE DRAWING	SCALE 2:1	DWG. NO. OL-178.6192.0000
SHEET 1 OF 1		REV. A

8

7

6

5

4

3

2

1