

THIS DRAWING AND THE INFORMATION CONTAINED WITHIN IT ARE CONFIDENTIAL AND MAY NOT BE COPIED OR DISCLOSED WITHOUT THE WRITTEN PERMISSION OF LITTELFUSE.

REVISIONS

ZONE	REV.	DESCRIPTION	DATE	APPROVED
	A	PCO #5300128. INITIAL DRAWING RELEASE. DSILVA	11/7/2022	L.ARGIL

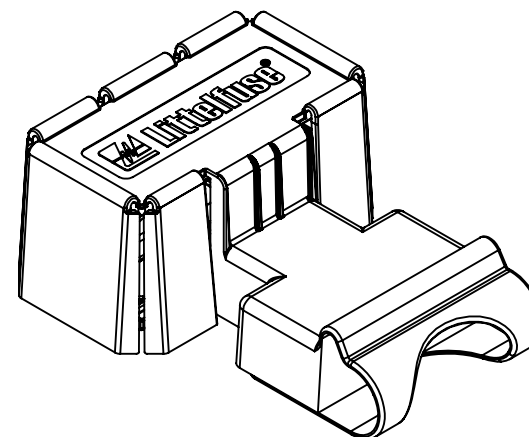
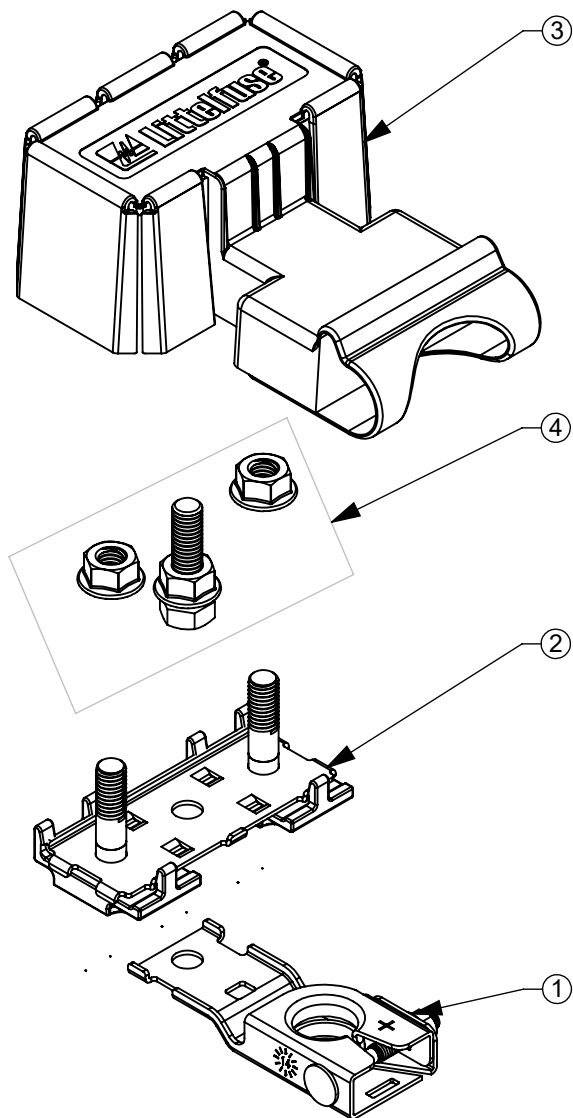

4	-	2WAY HARDWARE KIT	1	EA
3	901-325	COVER - ZCASE FUSE HOLDER	1	EA
2	-	SUB ASSM-ZCASE HOLDER 2WAY	1	EA
1	876-199	ZCASE SINGLE FUSE TERMINAL ASSM	1	EA
BOM #	COMPONENT PART NUMBER	COMPONENT NAME	QUANTITY	UNIT OF MEASURE

DIMENSIONS ARE SHOWN IN MILLIMETERS. DIMENSIONS AND TOLERANCES ARE DEFINED ACCORDING TO ANSI/ASME Y14.5-1994.

PER CHI-NPDD20-0008 PROCEDURE	●	FIT/ FUNCTION CRITICAL CHARACTERISTICS
	<S>	SAFETY/ COMPLIANCE CRITICAL CHARACTERISTICS SYMBOL
	CPK	DENOTES CPK DIMENSIONS MINIMUM CPK VALUE
	ST	DENOTES A CHARACTERISTIC THAT PROVIDES AN INDICATION OF PROCESS PERFORMANCE. PROCEDURE FOR MEASUREMENT AND TRACKING TO BE DEFINED IN LITTELFUSE INSPECTION INSTRUCTIONS
	CP	DENOTES CP DIMENSIONS, -MINIMUM CP VALUE MUST BE WITHIN THE DIMENSIONAL LIMITATIONS SHOWN ON DRAWING AND INITIALLY LOCATED TO ALLOW FOR MAXIMUM TOOL LIFE

	NAME	DATE
DRAWN	DSILVA	9/27/2022
CHECKED	-	-
	-	-
	-	-



Expertise Applied | Answers Delivered

FORM NO: CVP-PE40-0001 REV B
THIRD ANGLE PROJECTION

TITLE
ZCASE HOLDER ASSM 2WAY
KIT

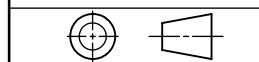

SIZE A	DWG. NO. OL-0FHZ00854-BX	REV. A
-----------	-----------------------------	-----------

DO NOT SCALE DRAWING

SCALE 1:2

SHEET 1 OF 1