

THIS DRAWING AND THE INFORMATION CONTAINED WITHIN IT ARE CONFIDENTIAL AND MAY NOT BE COPIED OR DISCLOSED WITHOUT THE WRITTEN PERMISSION OF LITTELFUSE.

REVISIONS

ZONE	REV.	DESCRIPTION	DATE	APPROVED
	A	PCO #5300128. INITIAL DRAWING RELEASE. DSILVA	11/7/2022	L.ARGIL

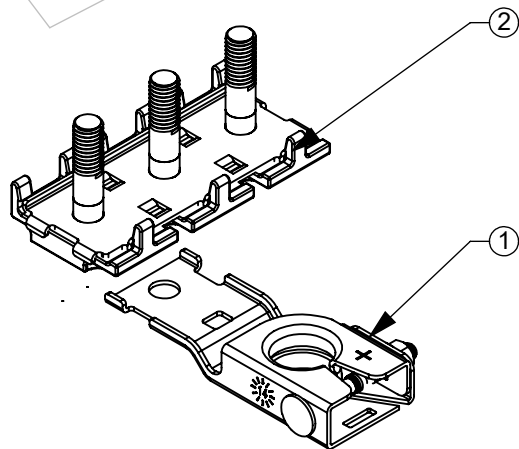
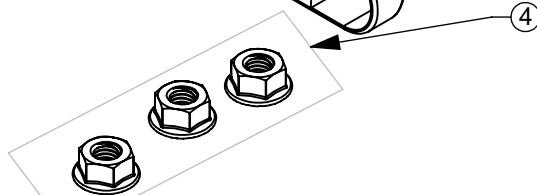
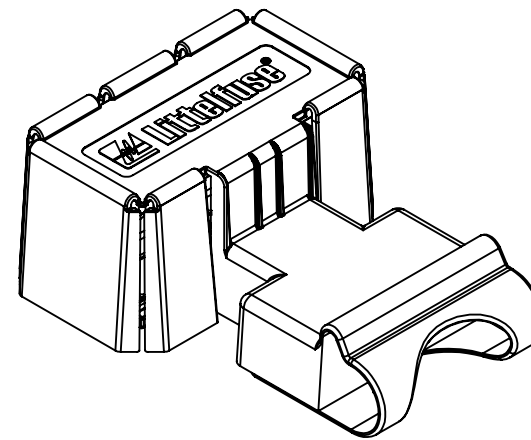
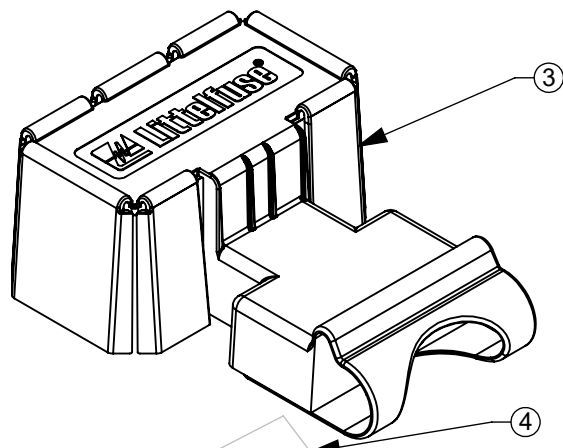

4	-	3WAY HARDWARE KIT	1	EA
3	901-325	COVER - ZCASE FUSE HOLDER	1	EA
2	882-853	ZCASE HOLDER ASSM 3WAY	1	EA
1	876-199	ZCASE SINGLE FUSE TERMINAL ASSM	1	EA
BOM #	COMPONENT PART NUMBER	COMPONENT NAME	QUANTITY	UNIT OF MEASURE

DIMENSIONS ARE SHOWN IN MILLIMETERS. DIMENSIONS AND TOLERANCES ARE DEFINED ACCORDING TO ANSI/ASME Y14.5-1994.

PER CHI-NPDD20-0008 PROCEDURE	●	FIT/ FUNCTION CRITICAL CHARACTERISTICS
	<S>	SAFETY/ COMPLIANCE CRITICAL CHARACTERISTICS SYMBOL
	CPK	DENOTES CPK DIMENSIONS MINIMUM CPK VALUE
	ST	DENOTES A CHARACTERISTIC THAT PROVIDES AN INDICATION OF PROCESS PERFORMANCE. PROCEDURE FOR MEASUREMENT AND TRACKING TO BE DEFINED IN LITTELFUSE INSPECTION INSTRUCTIONS
	CP	DENOTES CP DIMENSIONS, -MINIMUM CP VALUE MUST BE WITHIN THE DIMENSIONAL LIMITATIONS SHOWN ON DRAWING AND INITIALLY LOCATED TO ALLOW FOR MAXIMUM TOOL LIFE

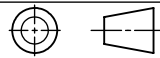
	NAME	DATE	 Expertise Applied Answers Delivered	
DRAWN	D.SILVA	9/27/2022		
CHECKED	-	-		
	-	-		
FORM NO: CVP-PE40-0001 REV B			TITLE ZCASE HOLDER ASSM 3WAY KIT	
THIRD ANGLE PROJECTION				
DO NOT SCALE DRAWING		SIZE A	DWG. NO. OUTLINE OL-0FHZ00853-BX	REV. A
		SCALE 1:2		SHEET 1 OF 1