

THIS DRAWING AND THE INFORMATION CONTAINED WITHIN IT ARE CONFIDENTIAL AND MAY NOT BE COPIED OR DISCLOSED WITHOUT THE WRITTEN PERMISSION OF LITTELFUSE.

REVISIONS				
REV.	DESCRIPTION	DATE	DESIGNED	APPROVED
A	First issue of outline drawing	29-May-20	L.Dal Molin	M.Tinto

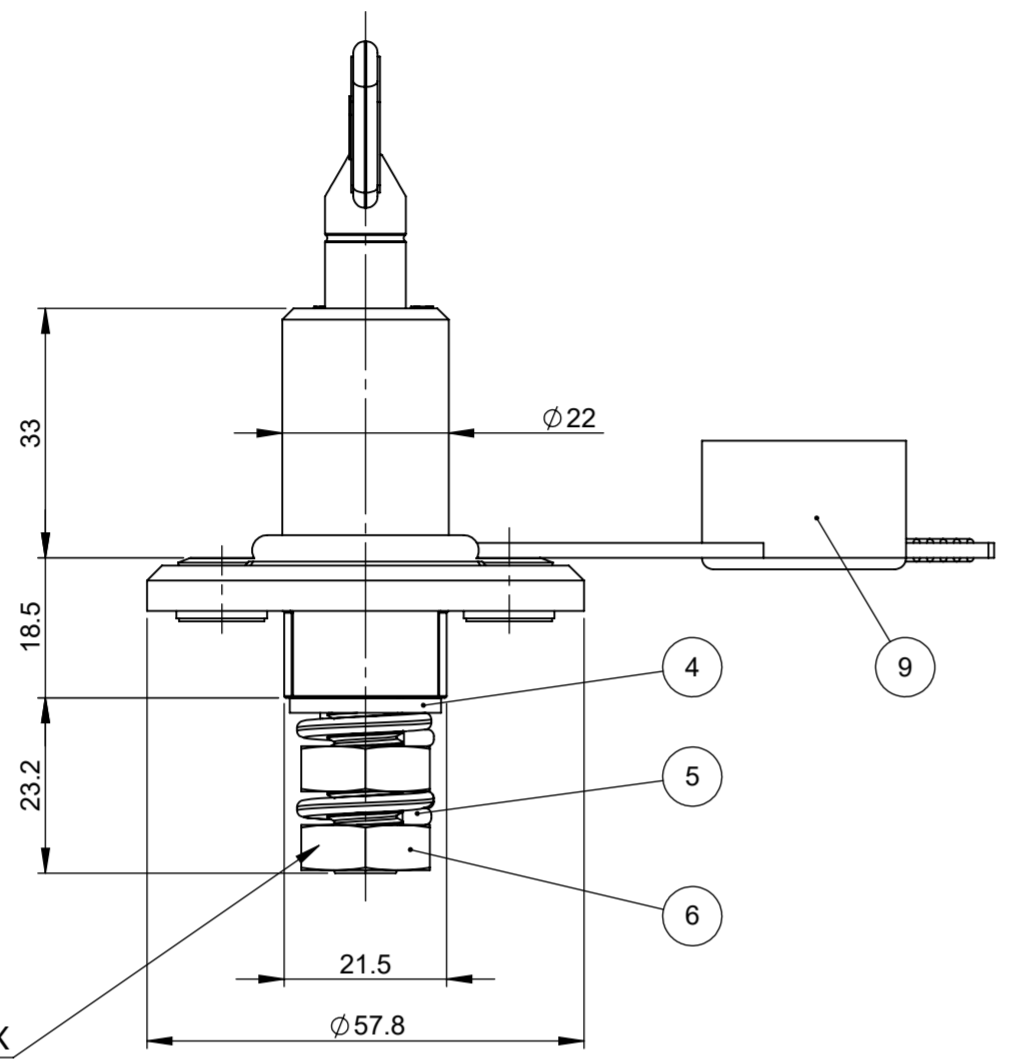

Tightening torque of M10 for cable fixing: 7 ± 1 Nm MAX

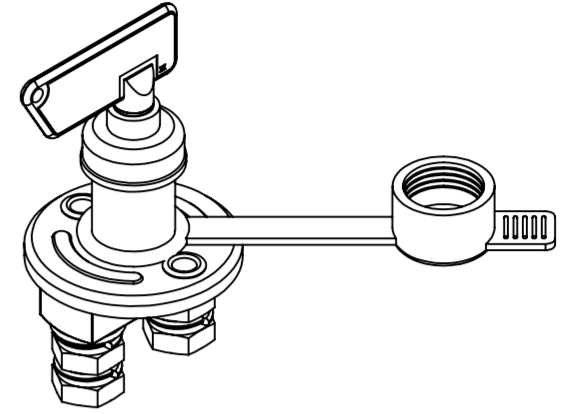
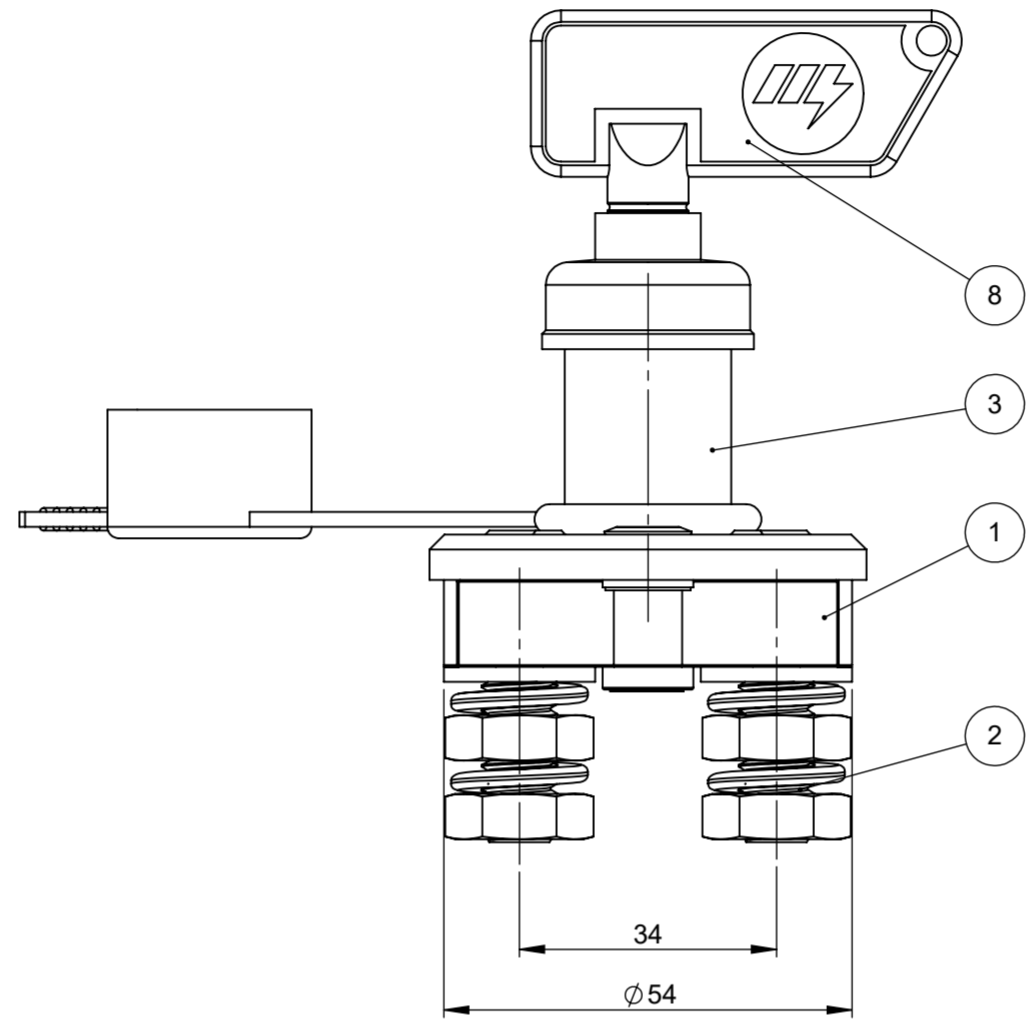

SCALE 1:2

POS.	P/N	DESCRIPTION	MATERIAL	Q.TY	U/M
9	00603900	Cap for Bms	Thermoplastic	1	EA
8	08099900	Key complete with cap	Polyamide, brass and thrmoplastic	1	EA
7		Eyelet	Iron	2	EA
6		Nut M10 low	Steel	4	EA
5		Spring washer To 10	Steel	4	EA
4		Washer Te 10.5x20	Steel	2	EA
3		Upper body cam double			
2		Power stud M10	Copper	2	EA
1		Lower body M10 cont.-holder hole	Polyamide	1	EA

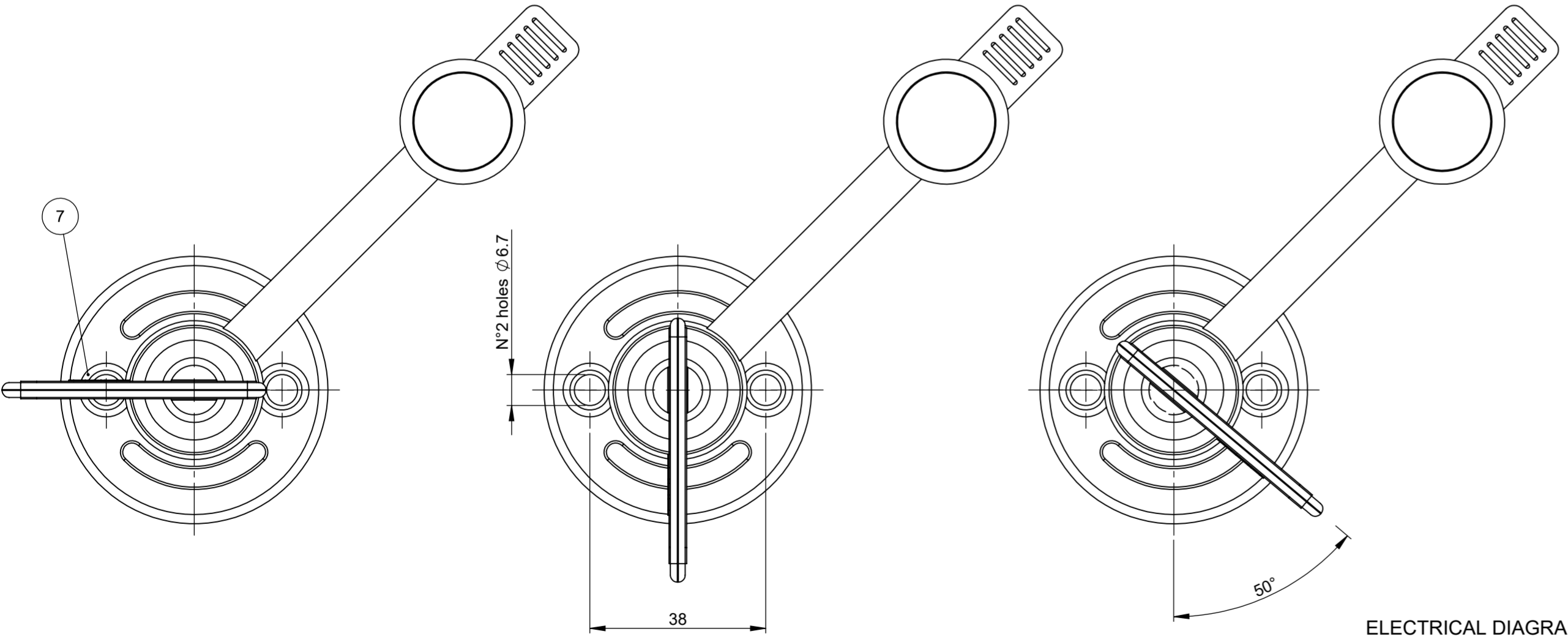

FEATURES

- Nominal voltage: 12-24V
- Max direct current: 150A
- Max short time current: 1000A for 5 seconds at 23±5°C
- Max short time current: 350A for 270 seconds at 23±5°C
- Number of electrical and mechanical operations: MIN. 5000
- M8 nuts tightening torque: 7 ± 1 Nm
- Supplying conditions: key, protection casing and cap are disassembled

ASSEMBLY KEY

To assemble the key, insert it and turn it clockwise of 50° taking the device in stated Switched OFF; to remove it, with the device in state Switched OFF turn it counterclockwise of 50° and extract it

OPERATION

- To close (switch on) the contacts: turn clockwise the key of 90°
- To open (switch off) the contacts: turn counterclockwise the key of 90°

ELECTRICAL DIAGRAM

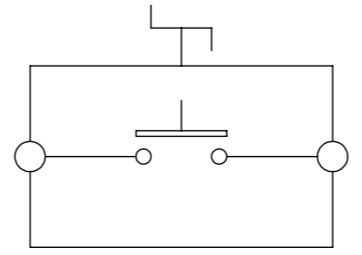

SAP drawing number:

Material and treatments:

DIMENSIONS AND TOLERANCES IN MILLIMETERS, DEFINED ACCORDING TO ISO 1101-2017.						
linear dimensions						
0,5 3	>3 6	>6 30	>30 120	>120 400	>400 1000	>1000 2000
±0,2	±0,3	±0,5	±0,8	±1,2	±2	±3
angle (for range of lengths)						
up to 10	>10 50	>50 120	>120 400			
±1°30'	±1°	±0°30'	±0°15'			
●	FIT/ FUNCTION CRITICAL CHARACTERISTICS SYMBOL					
<S>	SAFETY/ COMPLIANCE CRITICAL CHARACTERISTICS SYMBOL					
CPK	DENOTES CPK DIMENSIONS MINIMUM CPK VALUE					
ST	DENOTES A CHARACTERISTIC THAT PROVIDES AN INDICATION OF PROCESS PERFORMANCE.PROCEDURE FOR MEASUREMENT AND TRACKING TO BE DEFINED IN LITTELFUSE INSPECTION INSTRUCTIONS					
CP	DENOTES CP DIMENSIONS. MINIMUM CP VALUE MUST BE WITHIN THE DIMENSIONAL LIMITATIONS SHOWN ON DRAWING AND INITIALLY LOCATED TO ALLOW FOR MAXIMUM TOOL LIFE					
DRAWN		NAME		DATE		
CHECKED		L. Dal Molin		09-Apr-19		
FORM NO. CVP-PE40-0013 REV A		TITLE		BATTERY MAIN SWITCH IGC-150 (2-M10+PROTECTION)		
FIRST ANGLE PROJECTION		SIZE		A2		
DO NOT SCALE DRAWING		SCALE 1:1		SHEET 1 OF 1		



OL-08099080 A