

THIS DRAWING AND THE INFORMATION CONTAINED WITHIN IT ARE CONFIDENTIAL AND MAY NOT BE COPIED OR DISCLOSED WITHOUT THE WRITTEN PERMISSION OF LITTELFUSE.

REVISIONS		DATE	DESIGNED	APPROVED
REV. A	FIRST ISSUE OF OUTLINE DRAWING	06-July-2020	Gasparini	Tinto

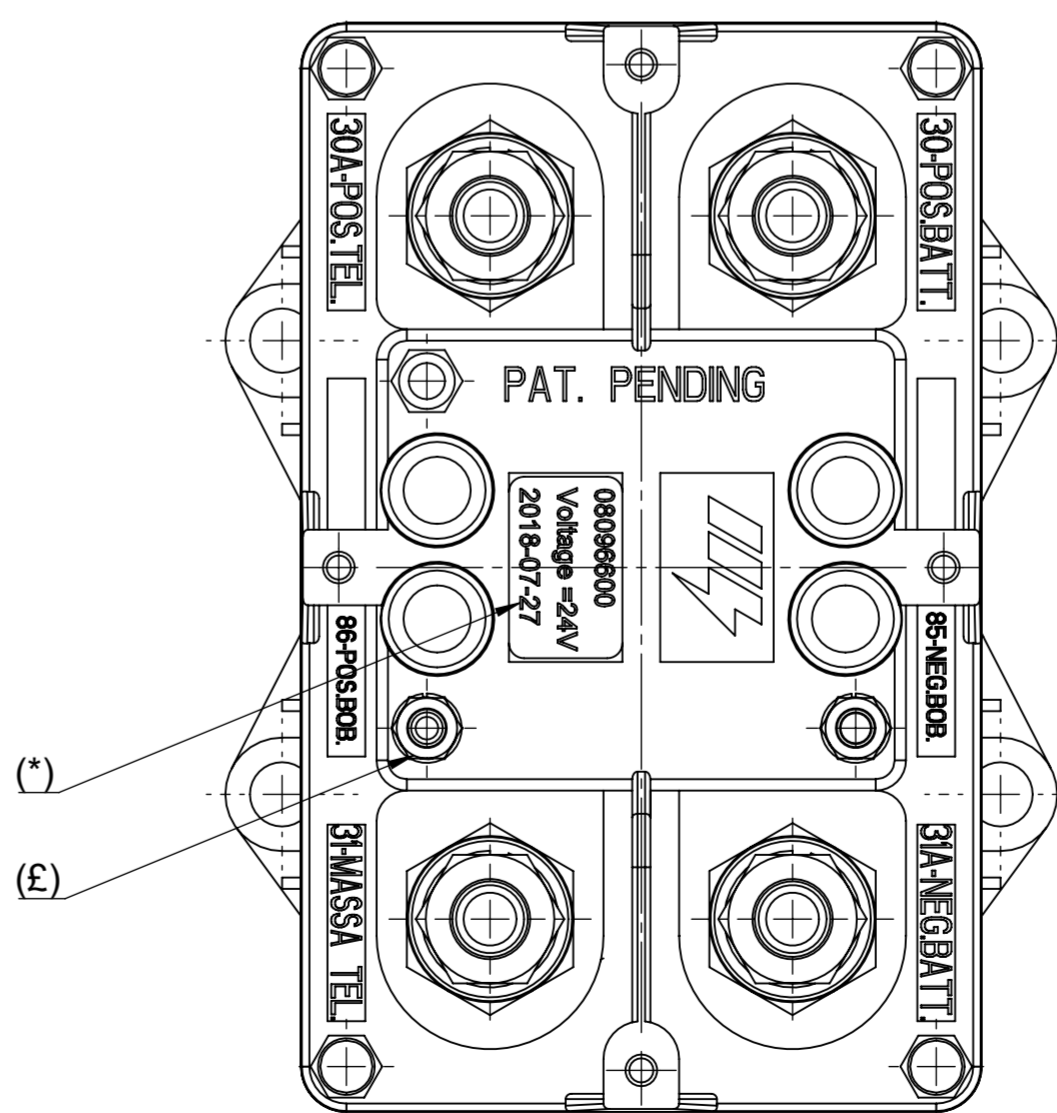
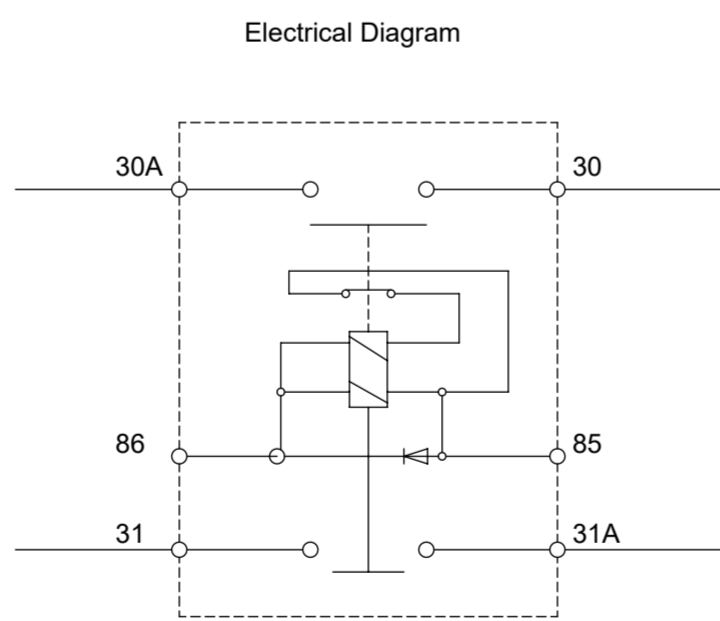
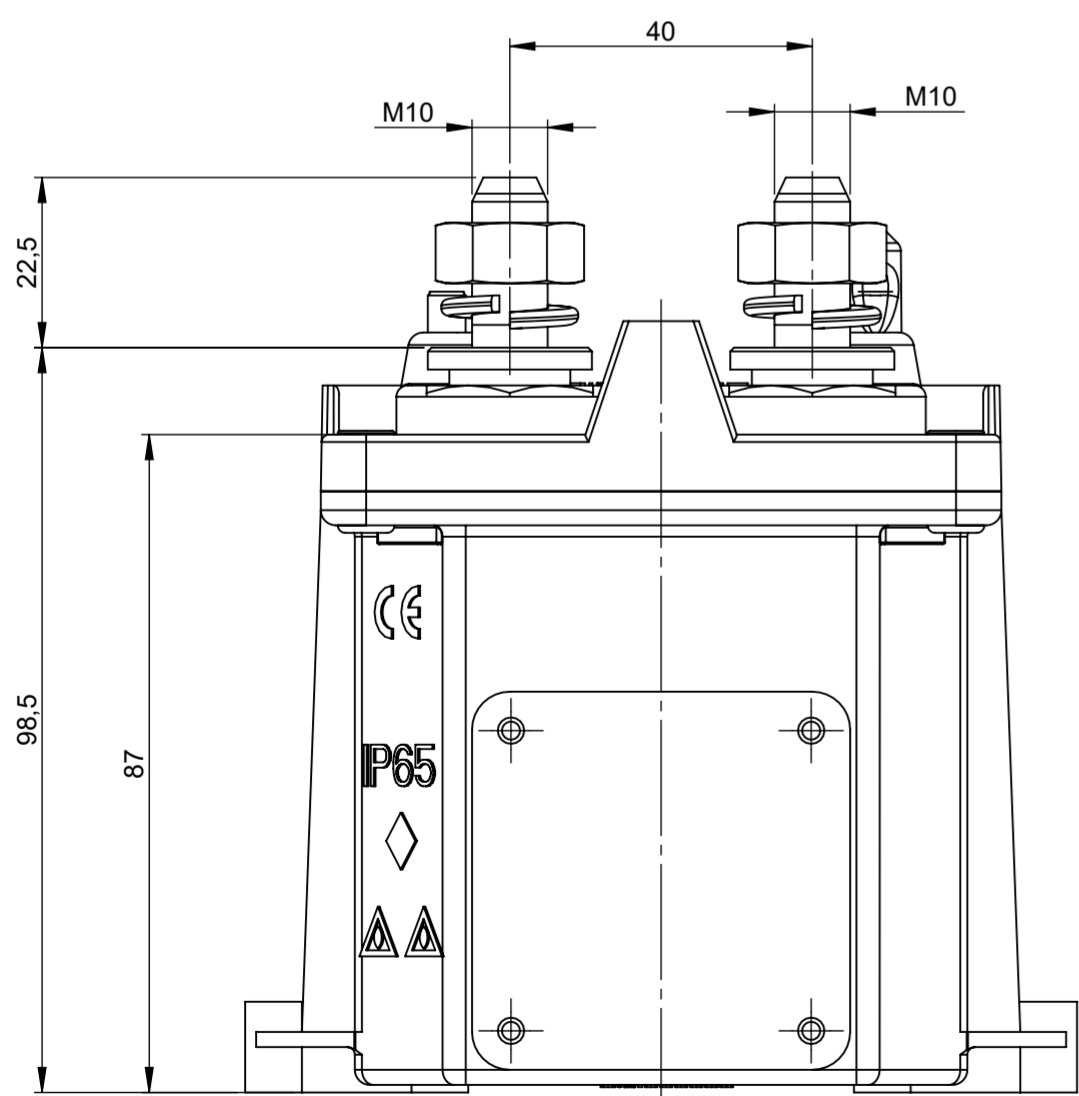
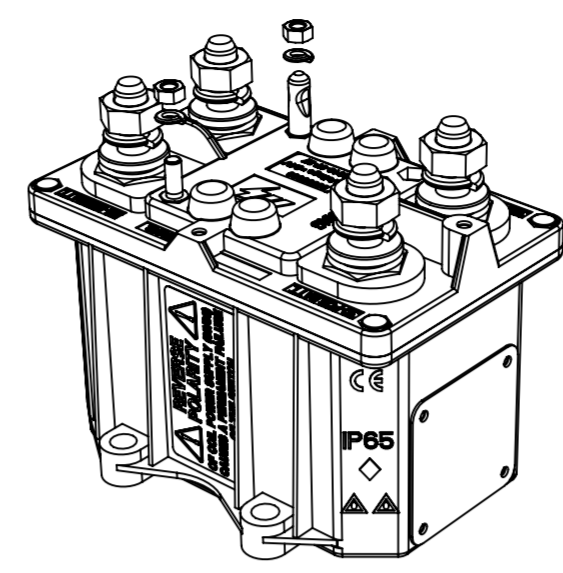
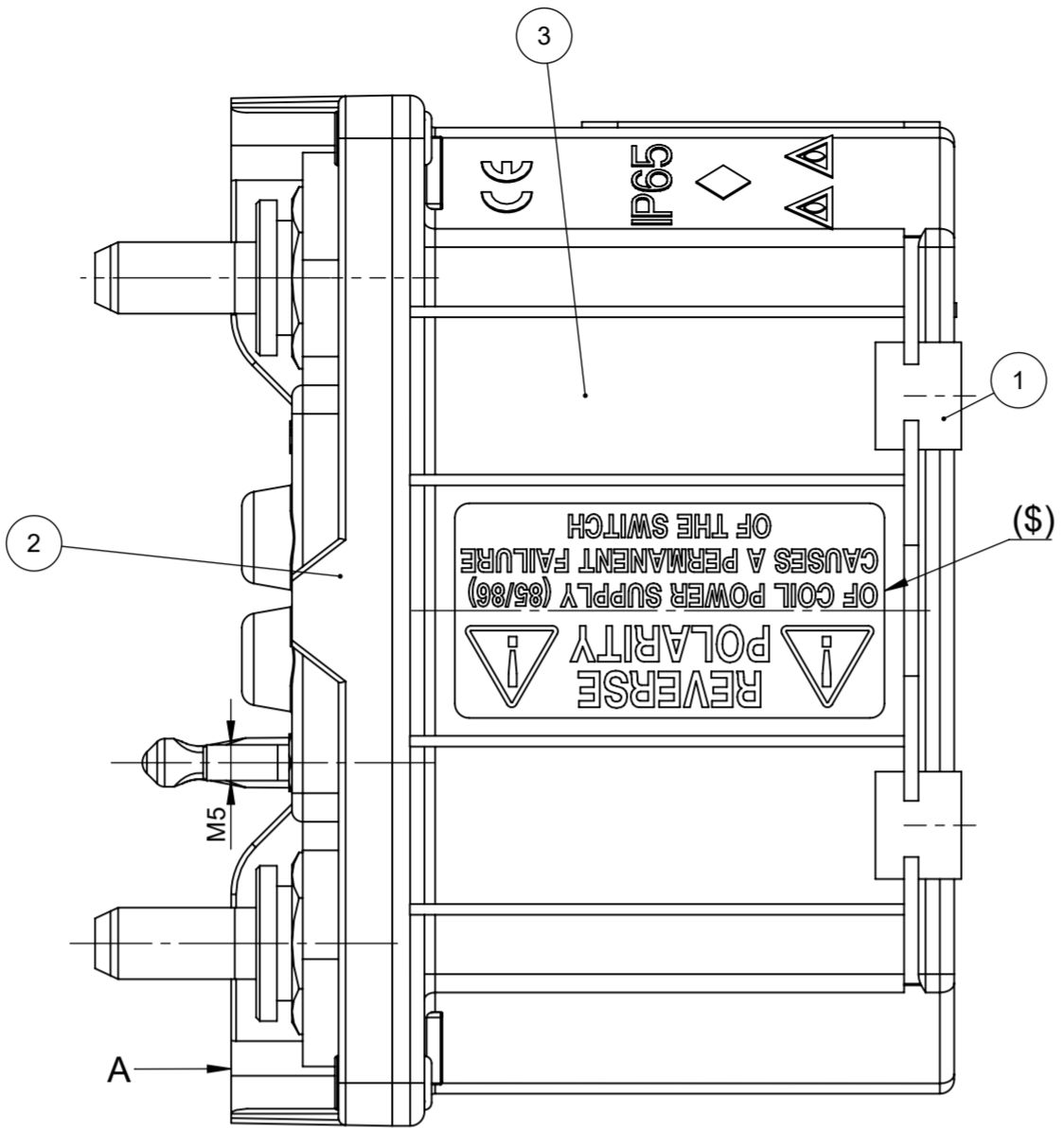
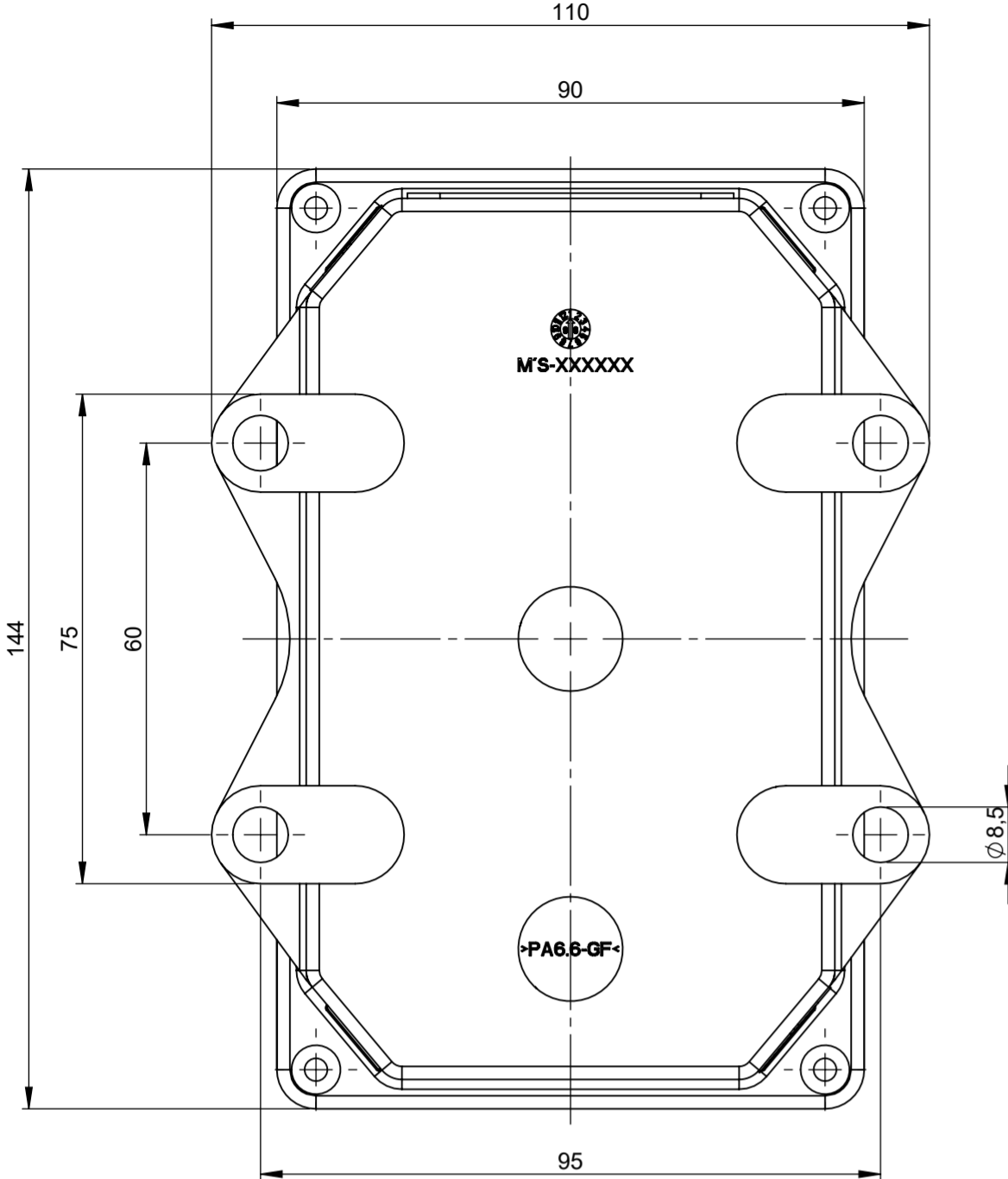

View from A

MECHANICAL CHARACTERISTICS
 - Number of electrical and mechanical operations: 100.000
 - Tightening torque nuts M10/M12: 20 Nm
 - Tightening torque nuts M5/M: 2 Nm

ELECTRICAL CHARACTERISTICS
 - Nominal voltage range: 12 - 24 V
 - Maximum continuous current on main contacts: 250 A at 23°C
 - Maximum short time current on main contact: 2000 A for 30 sec. at 23°C

PRESCRIPTIONS
 - (*): Manufacturing date
 - (\$): Label to be placed either on a box side or on the opposite side
 - (£): Cap for identification of M5 pin pos. coil, to be removed during the TGC installation phase on the vehicle

LEGEND
 1) Box
 2) Top cover
 3) Electrical BDS

SAP drawing number:

Material and treatments:

DIMENSIONS AND TOLERANCES IN MILLIMETERS, DEFINED ACCORDING TO ISO 1101-2017.	
linear dimensions	
0,5 3	>3 6
±0,2	±0,3
>6 30	>30 120
±0,5	±0,8
>120 400	>400 1000
±1,2	±2
>1000 2000	
±3	
angle (for range of lengths)	
up to 10	>10 50
±1°30'	±1°
>50 120	>120 400
±0°30'	±0°15'
● FIT/ FUNCTION CRITICAL CHARACTERISTICS SYMBOL	
<S> SAFETY/ COMPLIANCE CRITICAL CHARACTERISTICS SYMBOL	
CPK DENOTES CPK DIMENSIONS MINIMUM CPK VALUE	
ST DENOTES A CHARACTERISTIC THAT PROVIDES AN INDICATION OF PROCESS PERFORMANCE. PROCEDURE FOR MEASUREMENT AND TRACKING TO BE DEFINED IN LITTELFUSE INSPECTION INSTRUCTIONS	
CP DENOTES CP DIMENSIONS. MINIMUM CP VALUE MUST BE WITHIN THE DIMENSIONAL LIMITATIONS SHOWN ON DRAWING AND INITIALLY LOCATED TO ALLOW FOR MAXIMUM TOOL LIFE	
NAME	DATE
DRAWN L. Dal Molin	24/05/2019
CHECKED -	-
Littelfuse Expertise Applied Answers Delivered	
FORM NO. CVP-PE40-0913 REV A	
FIRST ANGLE PROJECTION	
SIZE: A2	DWG. NO. OL-08096600
DO NOT SCALE DRAWING	SCALE 1:1
SHEET 1 OF 1	