

THIS DRAWING AND THE INFORMATION CONTAINED WITHIN IT ARE CONFIDENTIAL AND MAY NOT BE COPIED OR DISCLOSED WITHOUT THE WRITTEN PERMISSION OF LITTELFUSE.

REV.	DESCRIPTION	DATE	DESIGNED	APPROVED
A	FIRST ISSUE OF OUTLINE DRAWING	20-May-19	Dal Molin	Tinto
B	Updated notes and added ISO view	3-Aug-22	L.Dal Molin	M.Tinto

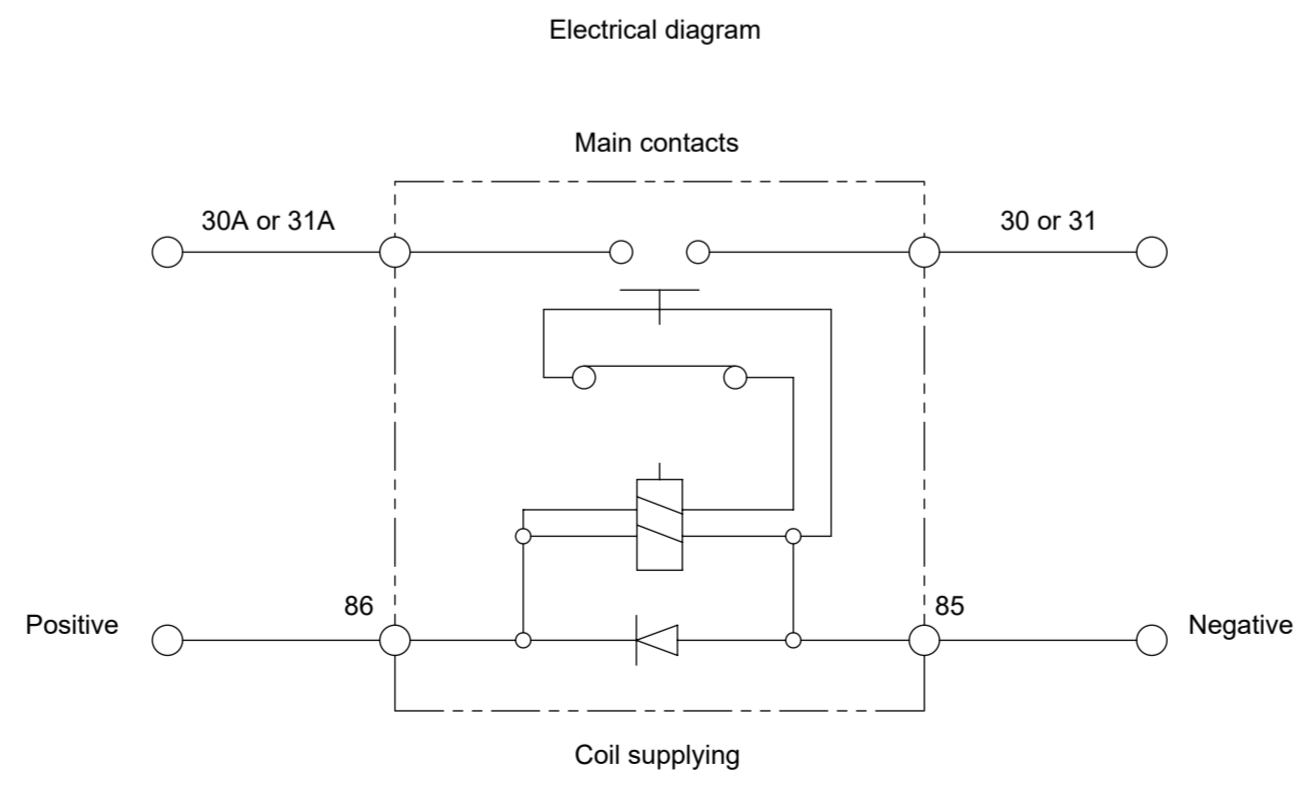
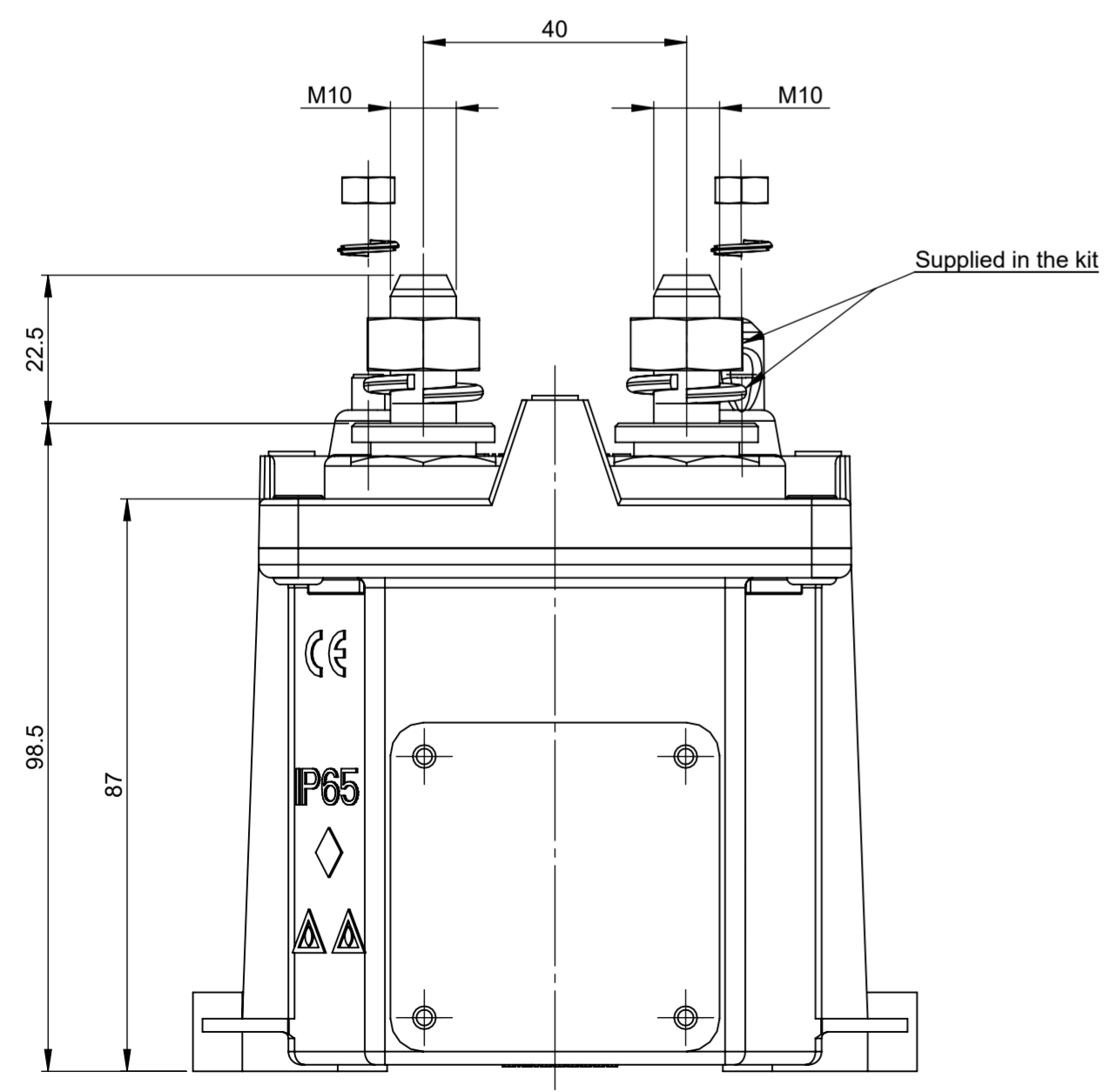
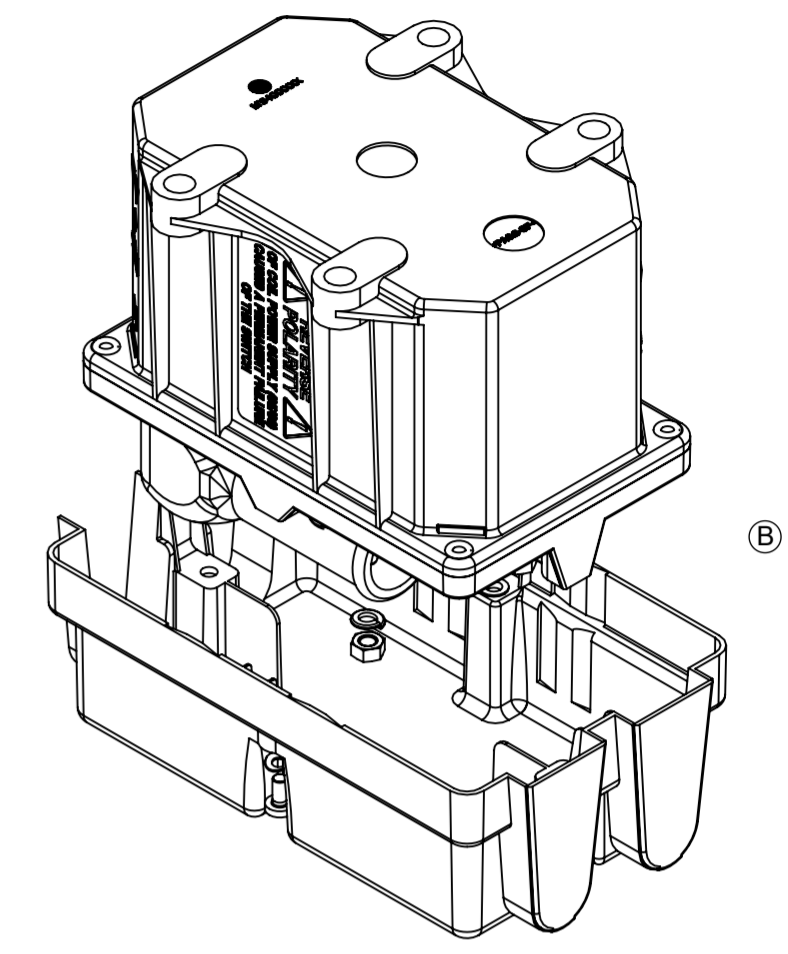
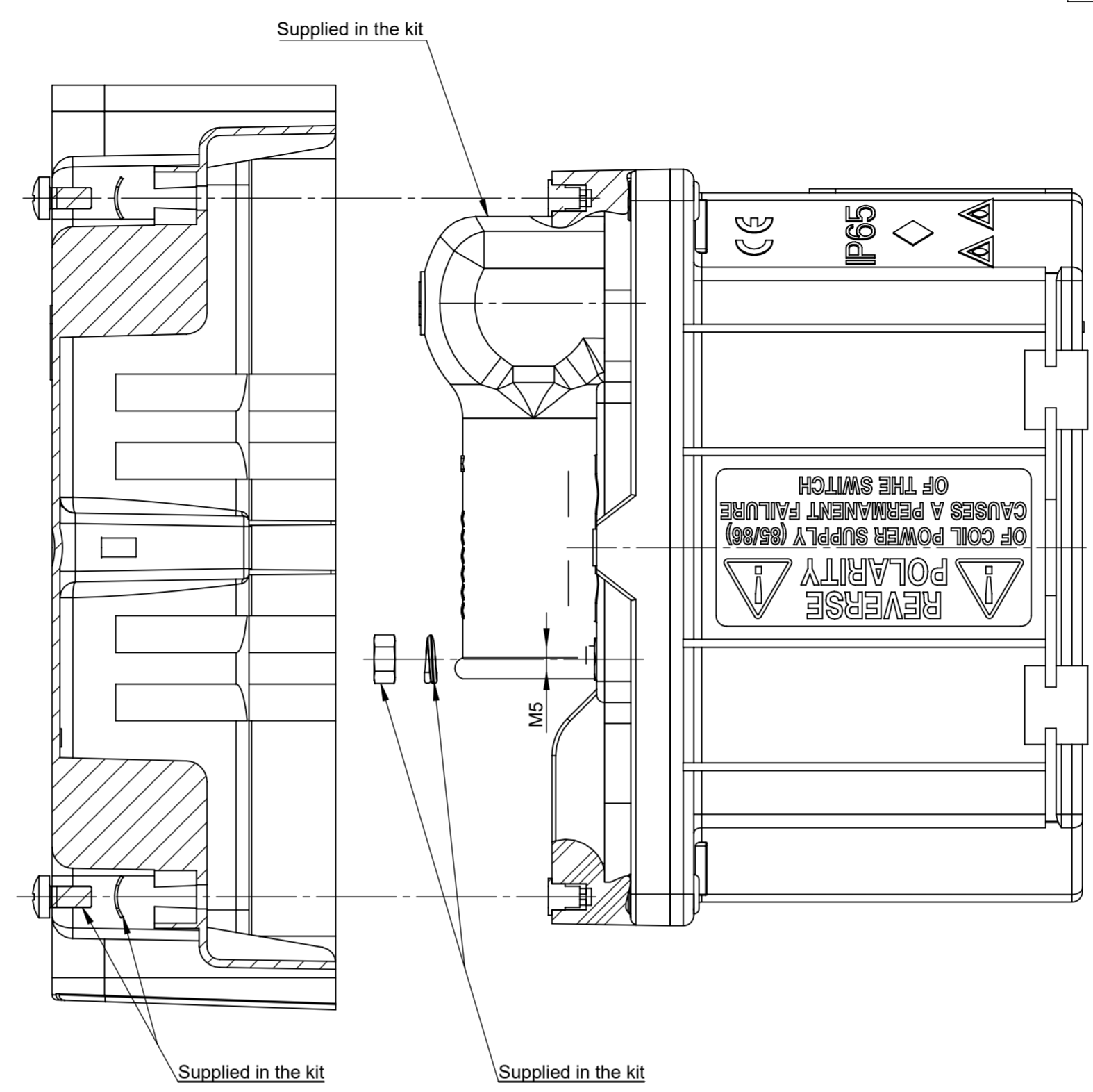
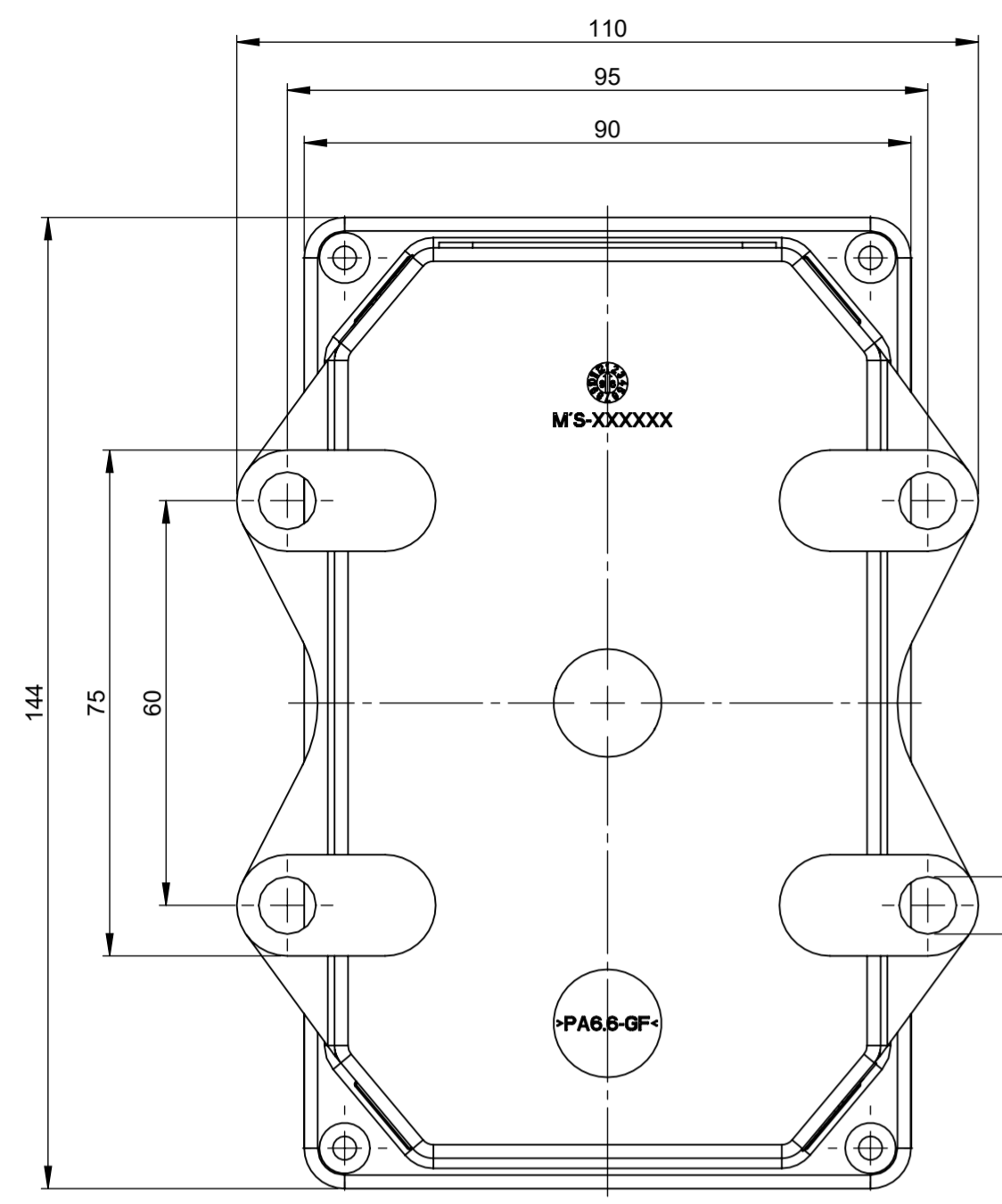

- (B) CHARACTERISTICS**
- Nominal voltage range: 12 + 24 V
 - Maximum continuous current on main contacts: 250A
 - Maximum short time current on main contacts: 2000A at 23°C for 30sec
 - Numbers of electrical and mechanical operations: 100.000
 - Tightening torque nuts M10/M12: 20Nm
 - Tightening torque nuts M5/M6: 1.6 ± 0.4 Nm
 - Fix the device to the structure by the M8 screws and plane washer with a torque of 10 ± 2Nm.

DIMENSIONS AND TOLERANCES IN MILLIMETERS, DEFINED ACCORDING TO ISO 1101-2017.						
linear dimensions						
0,5	>3	>6	>30	>120	>400	>1000
3	6	30	120	400	1000	2000
±0,2	±0,3	±0,5	±0,8	±1,2	±2	±3
angle (for range of lengths)						
up to	>10	>50	>120	>400	>120	>2000
10'	30'	50'	120'	400'	120'	2000'
±1°30'	±1°	±0°30'	±0°15'			
	FIT/ FUNCTION CRITICAL CHARACTERISTICS SYMBOL					
<S>	SAFETY/ COMPLIANCE CRITICAL CHARACTERISTICS SYMBOL					
CPK	DENOTES CPK DIMENSIONS MINIMUM CPK VALUE					
	DENOTES A CHARACTERISTIC THAT PROVIDES AN INDICATION OF PROCESS PERFORMANCE. PROCEDURE FOR MEASUREMENT AND TRACKING TO BE DEFINED IN LITTELFUSE INSPECTION INSTRUCTIONS					
CP	DENOTES CP DIMENSIONS. MINIMUM CP VALUE MUST BE WITHIN THE DIMENSIONAL LIMITATIONS SHOWN ON DRAWING AND INITIALLY LOCATED TO ALLOW FOR MAXIMUM TOOL LIFE					
NAME	DATE					
DRAWN	L. Dal Molin	20 May 2019				
CHECKED	-	-				
FORM NO. CVP-PE40-0013 REV A		TITLE				
FIRST ANGLE PROJECTION		General Electrical Main Switch TGC/S				
SIZE: A2		DWG. NO. OL-08094860		OUTLINE REV. B		
DO NOT SCALE DRAWING		SCALE 1:1		SHEET 1 OF 1		