

THIS DRAWING AND THE INFORMATION CONTAINED WITHIN IT ARE CONFIDENTIAL AND MAY NOT BE COPIED OR DISCLOSED WITHOUT THE WRITTEN PERMISSION OF LITTELFUSE.

REVISIONS		DATE	DESIGNED	APPROVED
REV. A	FIRST ISSUE OF OUTLINE DRAWING	05-Jul-2019	Dal Molin	Tinto
REV. B	Removed IP degree and working temperature	07-Feb-20	Dal Molin	Tinto
REV. C	Changed laser marking and removed BOM table. Updated and added notes.	14-Jul-22	L.Dal Molin	M.Tinto

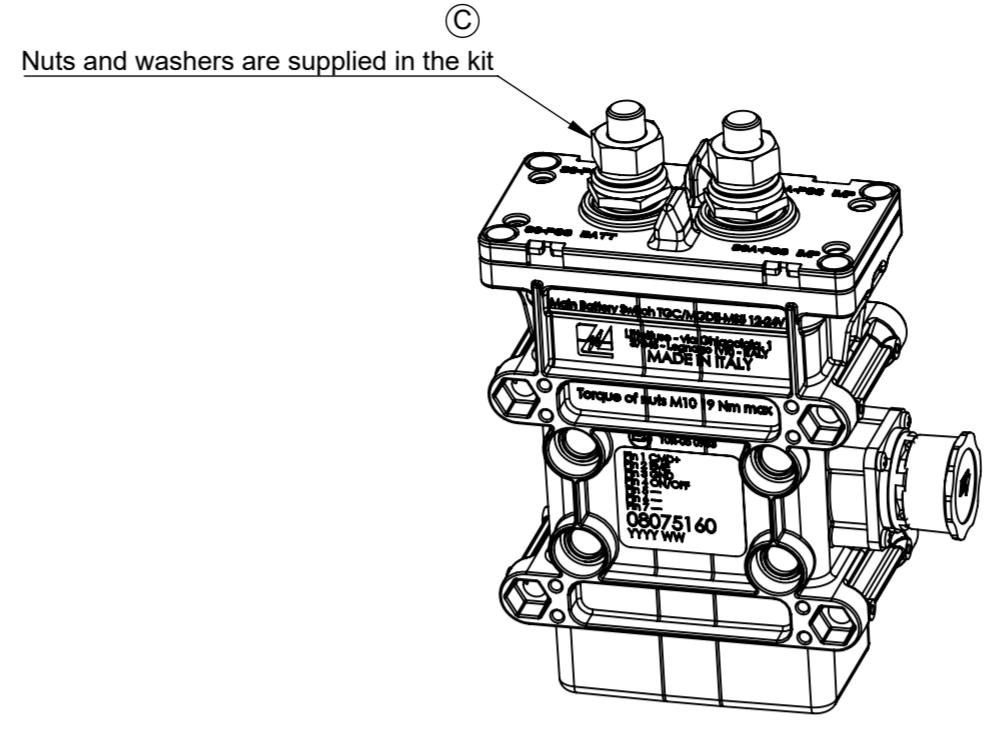
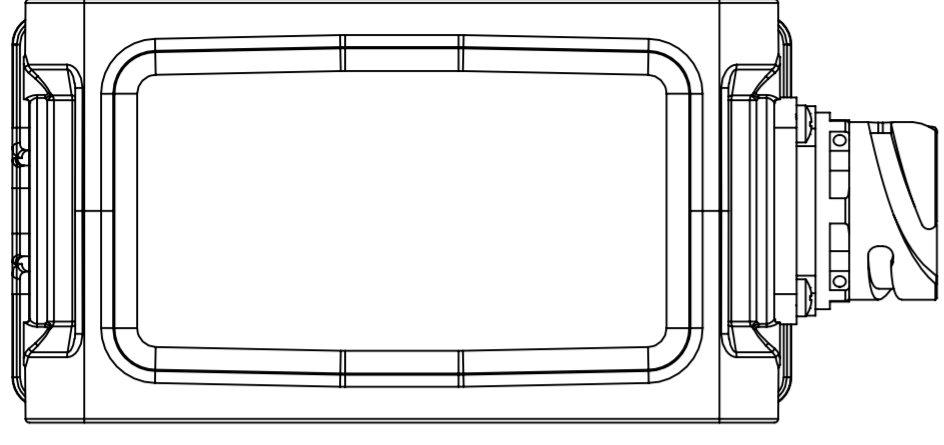

SCALE 1:2

Electrical Diagram

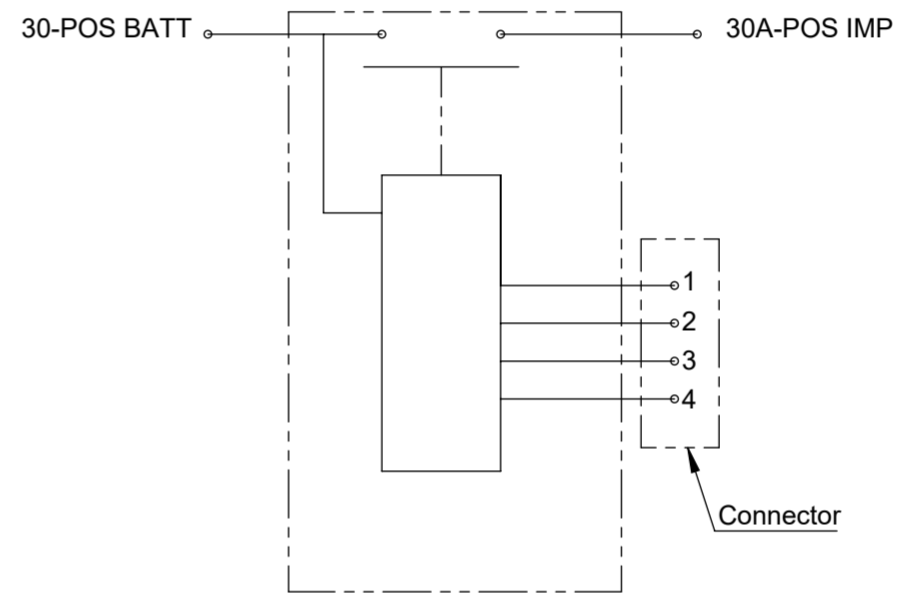

- 1- Main command positive supply
- 2- Emergency opening command line (immediate)
- 3- Device ground
- 4- Main closing/opening command line

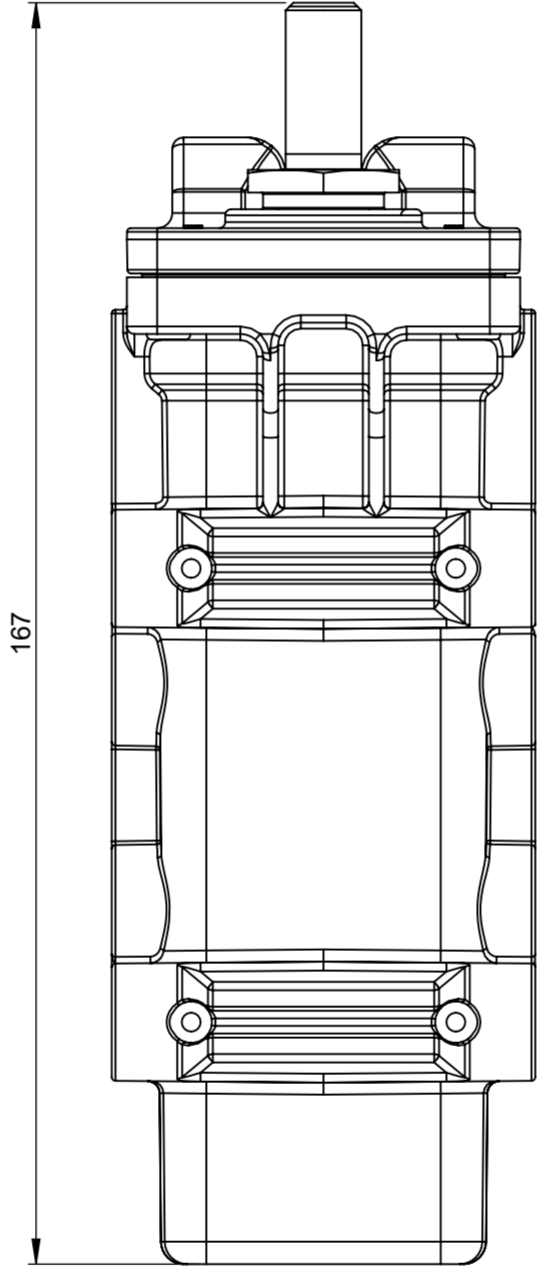
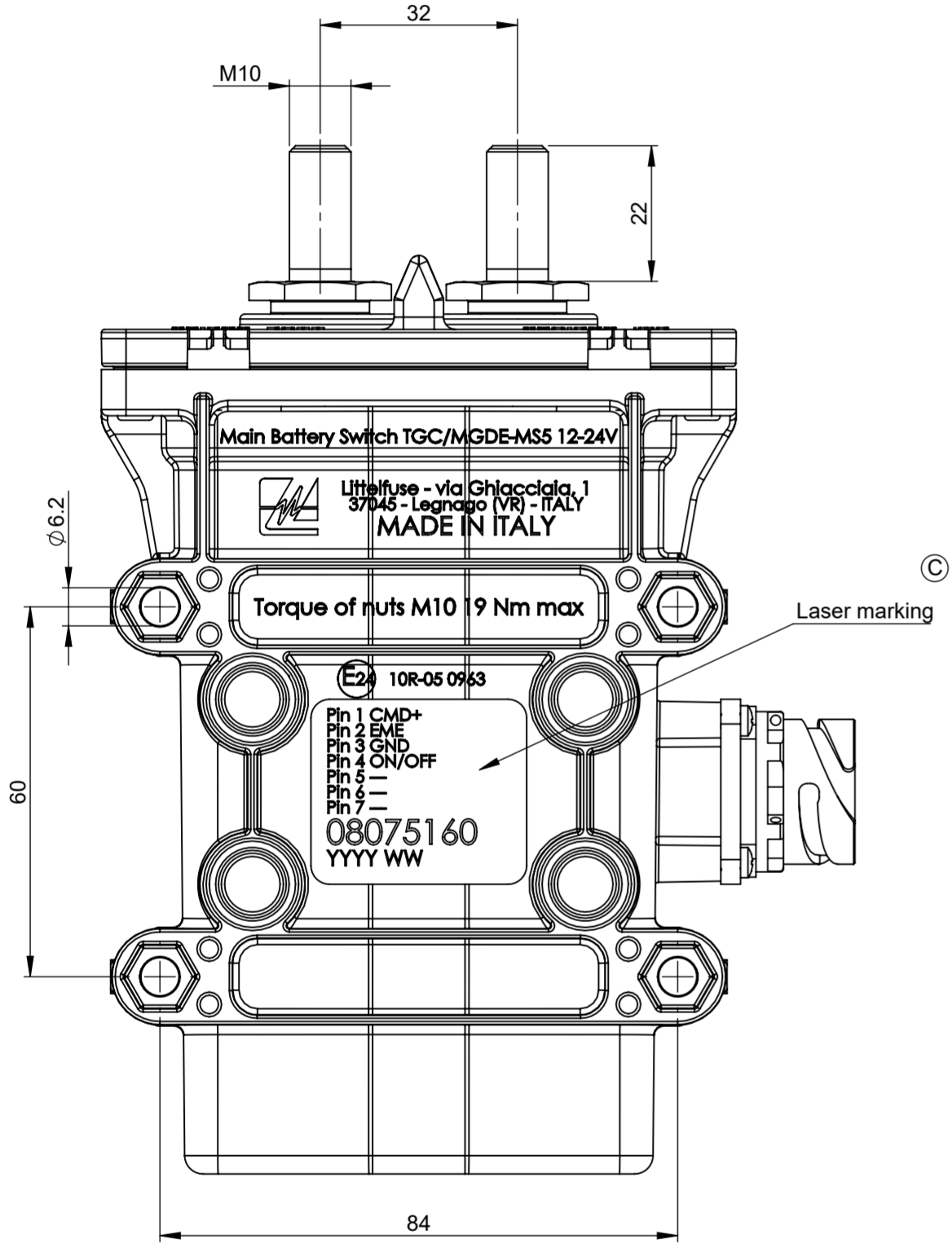

- PRESCRIPTIONS**
- Torque of screw M10/12= 18 ± 1 Nm
 - Fix the device with M6 screw and with torque of 6 ± 2 Nm

- CHARACTERISTICS**
- Nominal working tension: 24V
 - Nominal working current: 10A
 - Nominal working current main contact: 500A (1h at 23°C)
 - Nominal max current main contact: 2000A for 5 sec
 - Number of electrical operations: 50.000
 - Number of mechanical operations: 150.000

DIMENSIONS AND TOLERANCES IN MILLIMETERS, DEFINED ACCORDING TO ISO 1101-2017.						
linear dimensions						
0,5	>3	>6	>30	>120	>400	>1000
3	6	30	120	400	1000	2000
±0,2	±0,3	±0,5	±0,8	±1,2	±2	±3
angle (for range of lengths)						
up to 10	>10	>50	>120	>400	>1200	>2000
±1°30'	±1°	±0°30'	±0°15'			

● FIT/ FUNCTION CRITICAL CHARACTERISTICS SYMBOL		<p>Expertise Applied Answers Delivered</p>
<S> SAFETY/ COMPLIANCE CRITICAL CHARACTERISTICS SYMBOL		
CPK DENOTES CPK DIMENSIONS MINIMUM CPK VALUE		TITLE TGC/MGDE-MS5 12-24V TIME DELAY 6' 500A
ST DENOTES A CHARACTERISTIC THAT PROVIDES AN INDICATION OF PROCESS PERFORMANCE. PROCEDURE FOR MEASUREMENT AND TRACKING TO BE DEFINED IN LITTELFUSE INSPECTION INSTRUCTIONS		
CP DENOTES CP DIMENSIONS. MINIMUM CP VALUE MUST BE WITHIN THE DIMENSIONAL LIMITATIONS SHOWN ON DRAWING AND INITIALLY LOCATED TO ALLOW FOR MAXIMUM TOOL LIFE		FORM NO. CVP-PE40-0013 REV A FIRST ANGLE PROJECTION SIZE: A2 DWG. NO. OL-08075160 OUTLINE REV. C
DRAWN: L. Dal Molin, DATE: 07-May-19		
CHECKED: -		DO NOT SCALE DRAWING
		SCALE 1:1
		SHEET 1 OF 1

