

THIS DRAWING AND THE INFORMATION CONTAINED WITHIN IT ARE CONFIDENTIAL AND MAY NOT BE COPIED OR DISCLOSED WITHOUT THE WRITTEN PERMISSION OF LITTELFUSE.

REV.	DESCRIPTION	DATE	GCF / ECR	DESIGNED	APPROVED
A	EMISSIONE	08/05/2019		GASPARINI	CROVETTI

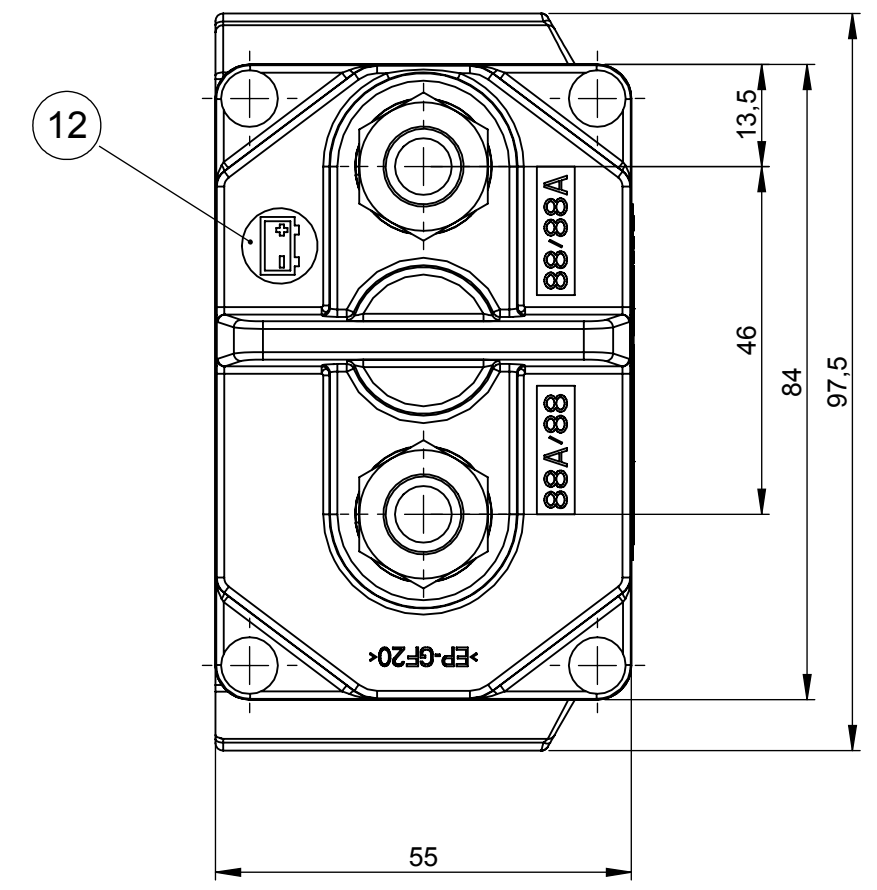
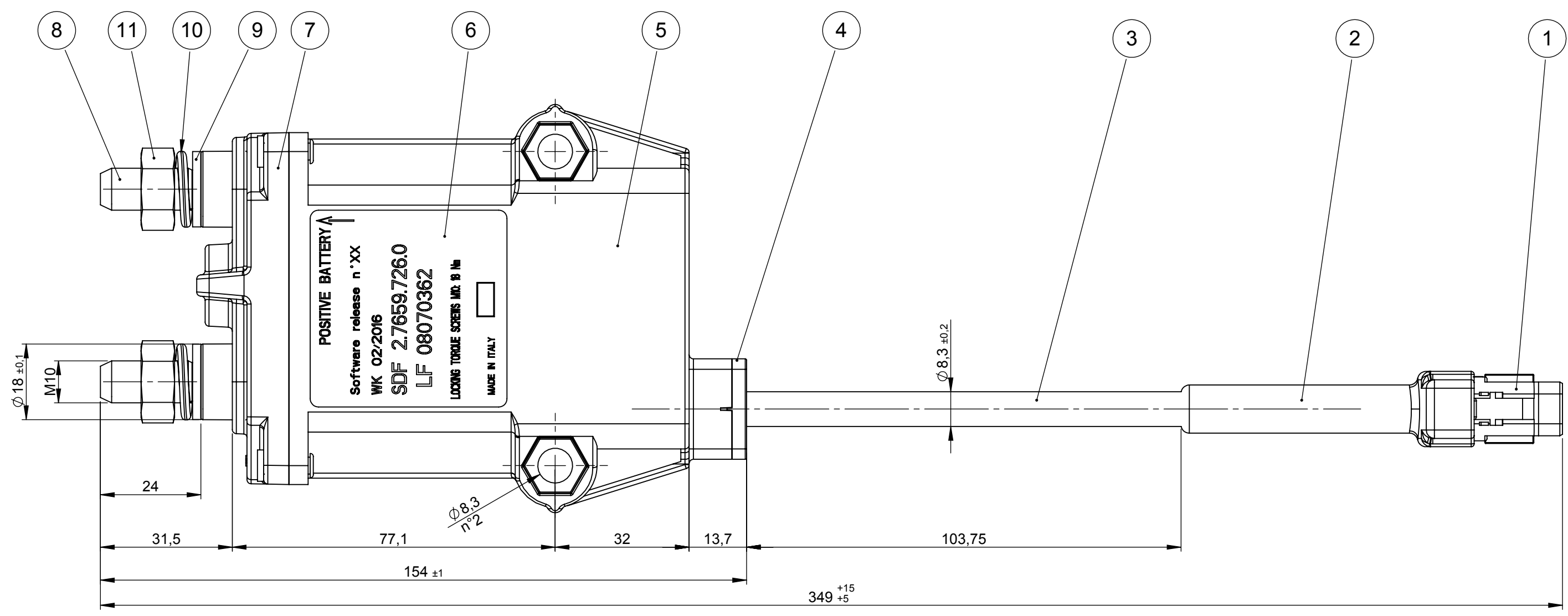

LEGENDA

- 1 Plug connector for socket contacts 8 ways DEUTSCH DTM06-08SA in thermoplastic colour grey
- 2 Rear cap DEUTSCH DTM8S-BT in rubber colour grey
- 3 7 ways waterproof wiring (7x1mm²)
- 4 Cable gland cover in thermoplastic PBT colour black
- 5 Box in thermoplastic PBT colour black
- 6 Adhesive indestructible label with manufacturing week and year, P/N and software release
- 7 Contacts holder cover in epoxy resin colour black
- 8 M10 main contacts in silver plated copper
- 9 Plane washer in Nickel plated brass
- 10 spring washer in Nickel plated bronze
- 11 M10 nut in Nickel plated brass
- 12 Red label battery pole

FEATURES

- Nominal working voltage V_n = 12V
- Min. switch voltage V_{min} = 9.5V
- Max continuous current I_{max} = 250A
- Max current x 30 sec I = 800A
- Max current x 5 sec I = 2000A
- Operating temperature range T = -40 ÷ + 85 °C

NOTES

- Supplying state: main contact open
- Fit the device to the structure by means of screws M8 with locking torque 10 ± 2Nm

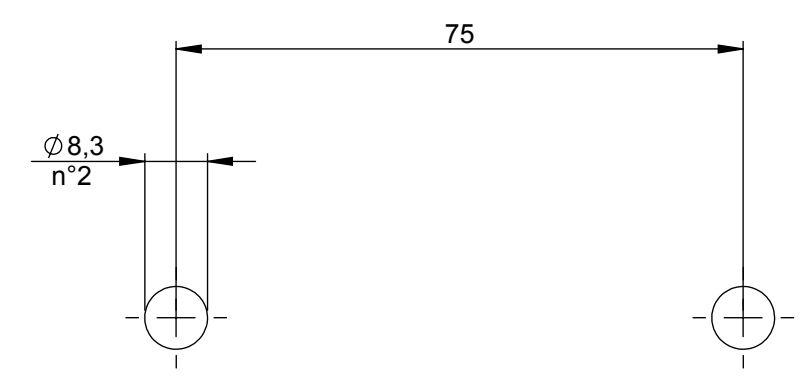
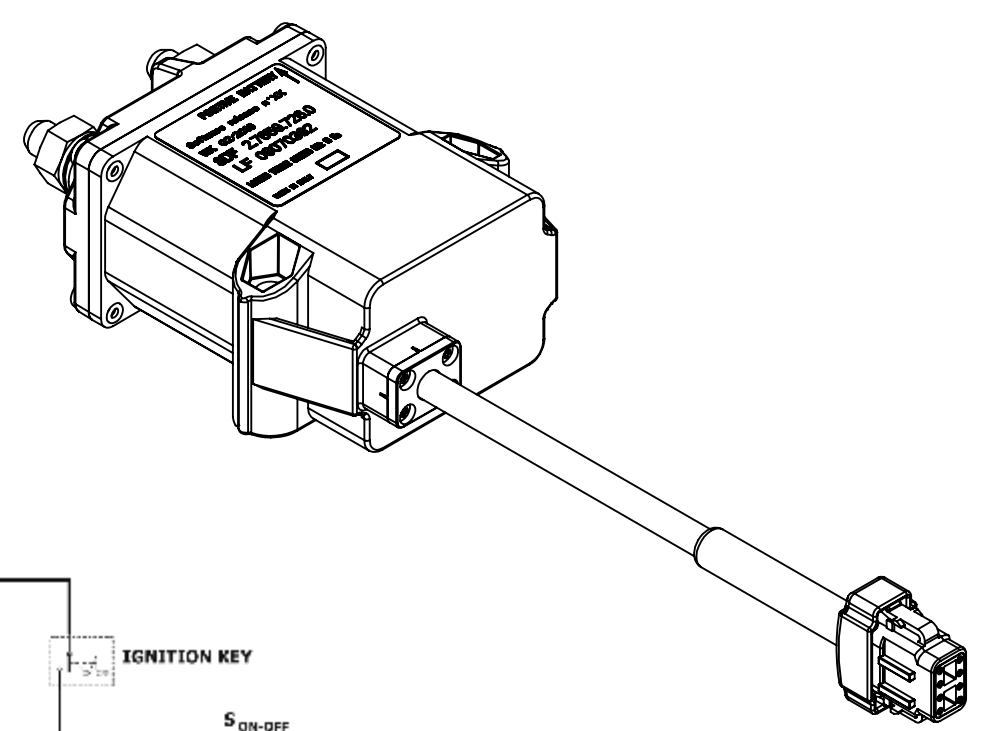

DIMA DI MONTAGGIO
Mounting template

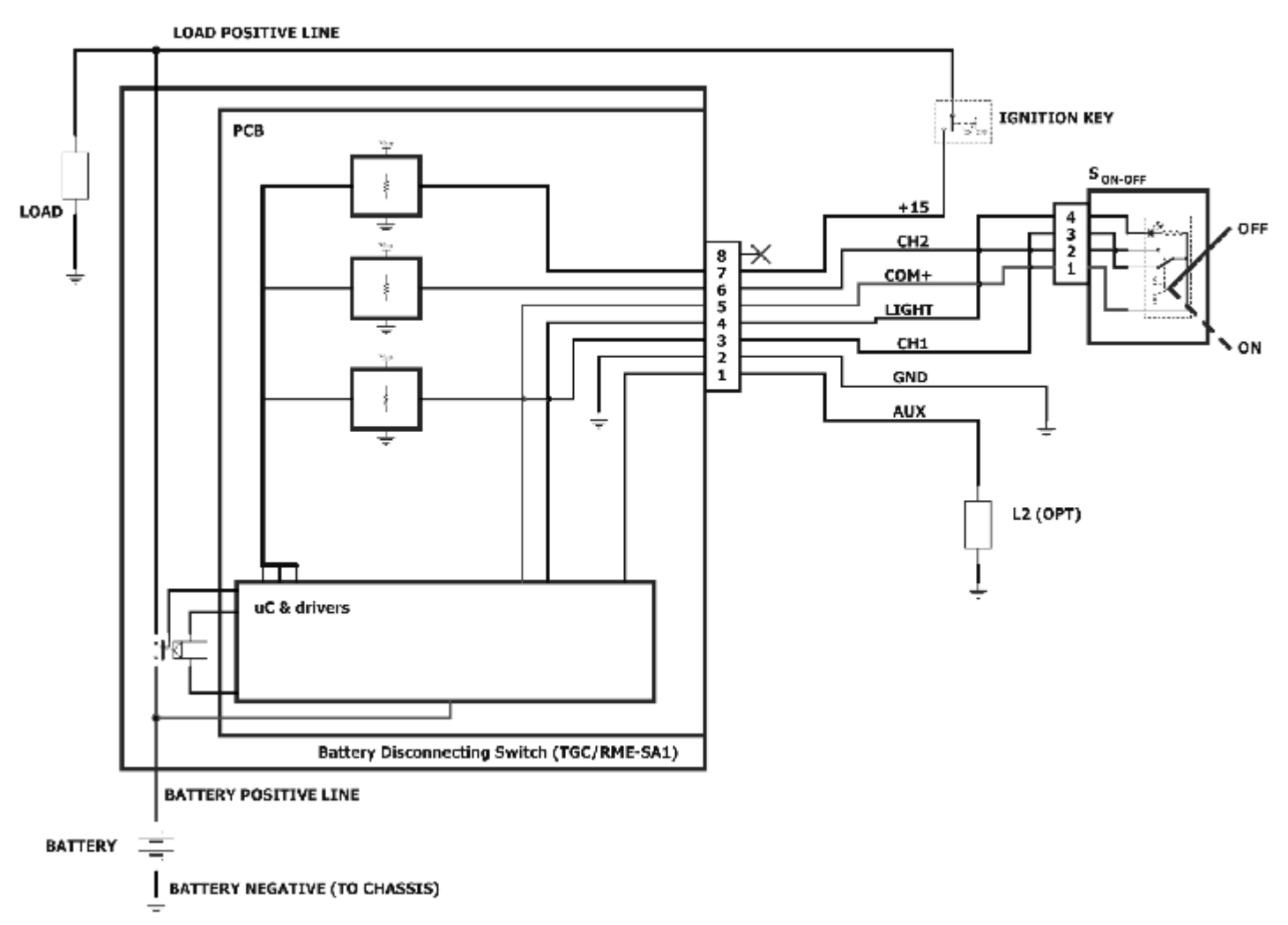

SAP drawing number

DIMENSIONS AND TOLERANCES IN MILLIMETERS, DEFINED ACCORDING TO ISO 1101-2017.	
●	FIT/ FUNCTION CRITICAL CHARACTERISTICS SYMBOL
<S>	SAFETY/ COMPLIANCE CRITICAL CHARACTERISTICS SYMBOL
CPK	DENOTES CPK DIMENSIONS MINIMUM CPK VALUE
ST	DENOTES A CHARACTERISTIC THAT PROVIDES AN INDICATION OF PROCESS PERFORMANCE PROCEDURE FOR MEASUREMENT AND TRACKING TO BE DEFINED IN LITTELFUSE INSPECTION INSTRUCTIONS
CP	DENOTES CP DIMENSIONS. MINIMUM CP VALUE MUST BE WITHIN THE DIMENSIONAL LIMITATIONS SHOWN ON DRAWING AND INITIALLY LOCATED TO ALLOW FOR MAXIMUM TOOL LIFE
TOLERANCES UNLESS OTHERWISE SPECIFIED: ONE PLACE DECIMAL ± 0.5 THREE PLACES DECIMAL ± 0.100 TWO PLACES DECIMAL ± 0.20 ANGULAR ± 2'	
NAME	DATE
DRAWN: F. Gasparini	08/05/2019
CHECKED: -	-
Littelfuse Expertise Applied Answers Delivered	
FORM NO. CVP-PE40-0012 REV A	TITLE: Electrical BMS TGC/RME-SA1 12V 1hr
FIRST ANGLE PROJECTION	SIZE: A2 DWG. NO. OL-08070362 REV. A
DO NOT SCALE DRAWING	SCALE 1:1 SHEET 1 OF 1