

COVER PART	COVER OPENING POSITION	MEGAFUSE IN HOLDER
A	C E F	0298450.ZXH
B	A C E	0298225.ZXEH
C	B E	0298100.ZXEH

LTR	DATE	REVISION	CHK	APD
A	05/25/05	61735 - RELEASED	GLAB	
B	04/05/07	85414D-REDRAWN IN UG	GMB	
C	08/31/07	000170EC/C - REMOVE USA FROM COVER	BRK	
D	04/24/08	000463EC/D-CHG. NOTE 2 ADDED NOTES	GMB	
E	09/11/13	509473ECA-IN CHART ADD COLUMN: MEGAFUSE IN HOLDER	OPL	

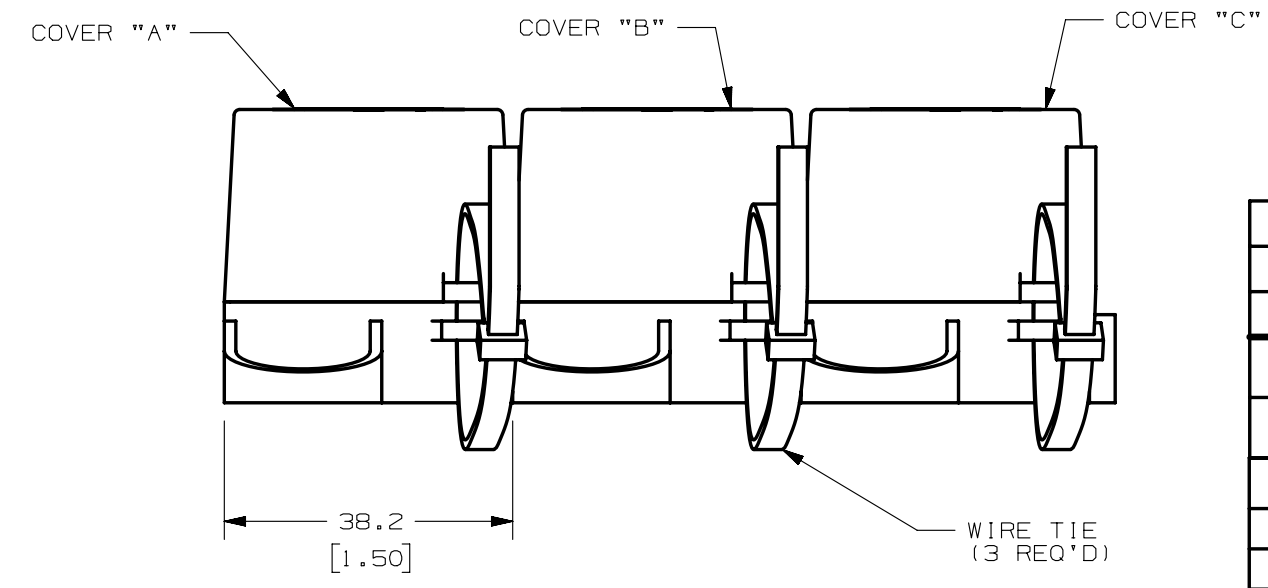
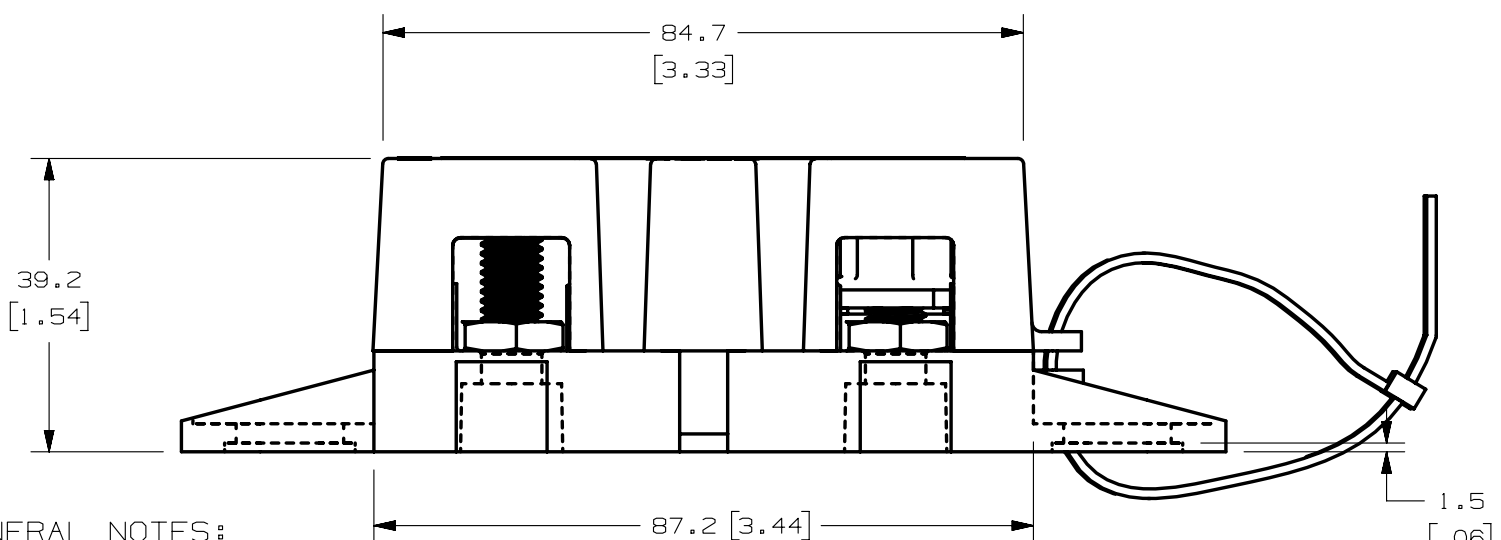
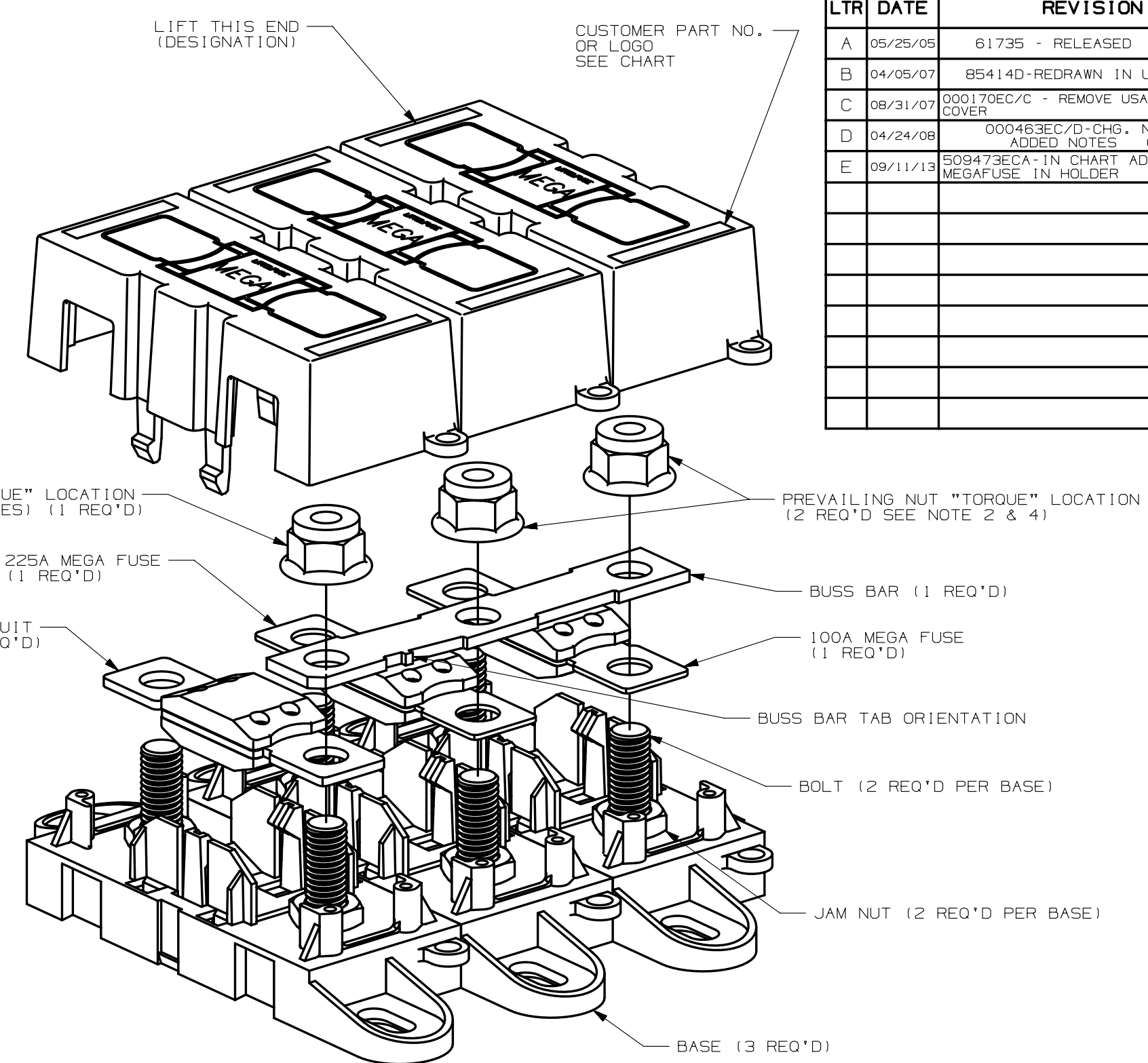
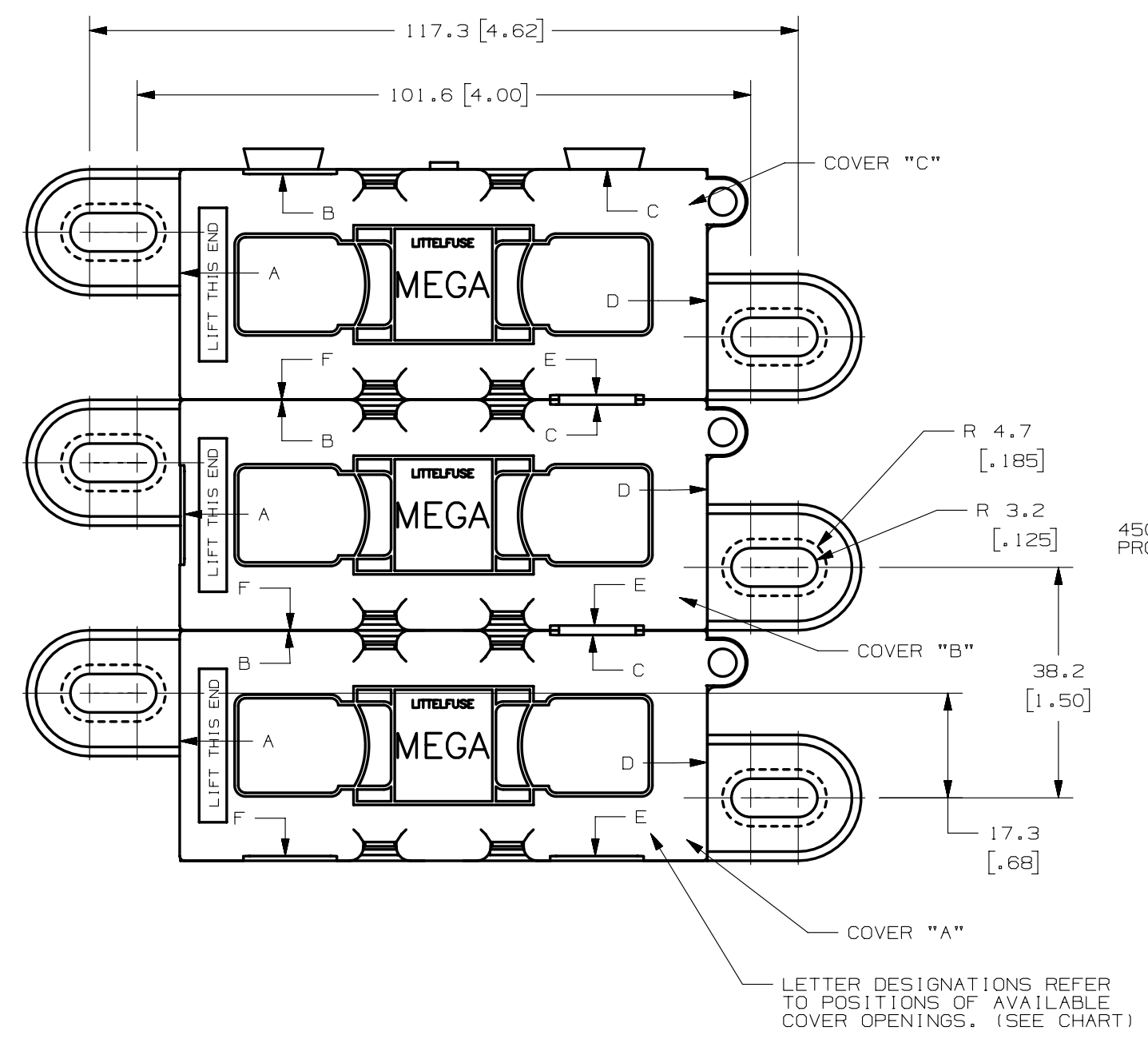

**GENERAL NOTES:**

- COVER RETENTION TEST: MINIMUM FORCE OF 2 LBS. IS REQUIRED TO REMOVE COVER WHEN IT IS SUSPENDED UPSIDE DOWN. FORCE SHALL BE APPLIED THROUGH THE INNER HOLES (2) IN BASE. USE FIXTURE #T-C403 TO SUPPORT PART.
- TORQUE APPLIED TO ALL "TORQUE" LOCATIONS TORQUE REQUIREMENTS FOR THE HEX NUT USED TO SECURE THE BUSSBAR OR THE CUSTOMER RING TERMINAL TO THE MEGA FUSE TO BE:  
8mm NUT - 12-18 NEWTON METERS [106-159 IN-LBS]
- HOLDER MEETS L/F VALIDATION TEST SPEC. VS-005002.
- FLANGED LOCKNUT TO MEET THE FOLLOWING CRITERIA:  
FORD PART NO. W520202  
FINISH: S437.

**MATERIALS:**

- \* BODY - GLASS FILLED THERMOPLASTIC  
COLOR - BLACK
- \* COVER - THERMOPLASTIC  
COLOR - BLACK
- \* WIRE TIE - THERMOPLASTIC  
COLOR - BLACK
- \* STUDS & NUTS - M8 X 1.25 STEEL ZINC PLATE WITH TRIVALENT CHROMATE, LEACHED AND SEALED, INTEGRAL TORQUE CONTROL LUBRICANT FINISH, (MEETS 96 HR. ASTM STD. B-117 SALT SPRAY REQ.)

- MANUALLY ASSEMBLE FLANGED PREVAILING NUT ONTO STUD UP TO THE BOTTOM OF THE PLASTIC INSERT IN THE NUT, FOR ALL "NO TORQUE" LOCATIONS.

NO	COMPONENT NO	DESCRIPTION	QTY/M	U/M
BILL OF MATERIAL				
UNLESS OTHERWISE SPECIFIED, DIMENSIONS ARE IN MILLIMETERS. DIMENSIONS IN BRACKETS [ ] ARE INCHES				
UNLESS OTHERWISE SPECIFIED, DIMENSIONS DO NOT INCLUDE PLATING.				
⊙	DENOTES CRITICAL CHARACTERISTICS.			
CPK	DENOTES CPK DIMENSIONS, -MINIMUM CPK VALUE			
ST	DENOTES A CHARACTERISTIC THAT PROVIDES AN INDICATION OF PROCESS PERFORMANCE. PROCEDURE FOR MEASUREMENT AND TRACKING TO BE DEFINED IN LITTELFUSE INSPECTION INSTRUCTIONS			
CP	DENOTES CP DIMENSIONS, -MINIMUM CP VALUE MUST BE WITHIN THE DIMENSIONAL LIMITATIONS SHOWN ON DRAWING AND INITIALLY LOCATED TO ALLOW FOR MAXIMUM TOOL LIFE			
COPIES TO		MATL SPEC		
1	9	18	FINISH	
2	10	19		
3	12	20		
4	13	21	DRW	GLAB
5	14	23	DATE	05/25/05
6	15	33	CHK	DATE
7	16	43	APPD	DATE
8	17	53	FINSH	GOOD WT
GRAMS/PIECE				
TOLERANCE UNLESS OTHERWISE SPECIFIED				
ONE PLACE DEC +/- .3		THREE PLACE DEC +/- .100		
TWO PLACE DEC +/- .25		ANGULAR +/- 1°		
3RD ANGLE PROJECTION		TITLE		
		3 POLE MEGA HOLDER FOR 450A, 225A & 100A		
Littelfuse		REVISION	DRWG. NO.	OUTLINE
		E	02983004ZXT	

METRIC

CAD GENERATED DRAWING - NO PENCIL CHANGES ALLOWED