

PART NUMBER	COVER OPENING	BASE STYLE	FUSE	WASHER	WASHER QTY/M	HEX NUT TYPE	HEX NUT QTY/M	TETHER	RACHET FASTENER	RACHET FASTENER QTY
029B1001ZXT	A D	1	NO	YES	2000	MB	2000	YES	NO	NONE
029B1002ZXT	A D	2	NO	YES	2000	MB	2000	YES	NO	NONE
029B1003ZXT	A B C D E F	1	NO	YES	2000	MB	2000	YES	NO	NONE
029B1004ZXT	A C F	1	029B175.ZXEH	NO	NONE	NONE	NONE	YES	NO	NONE
029B1005ZXT	A C D E	1	NO	YES	2000	MB	2000	YES	NO	NONE
029B1006ZXT	A B C D E F	1	029B175.ZXA	NO	NONE	M6 FLANGE	2000	NO	YES	2000
029B1007ZXT	A E	2	029B200.ZXEH	YES	2000	MB	2000	NO	NO	NONE
029B1008ZXT	A D E	2	029B200.ZXEH	YES	2000	MB	2000	NO	NO	NONE
029B1009ZXT	D E F	1	029B175.ZXA	NO	NONE	NONE	NONE	NO	NO	NONE
029B1010ZXT	A C D E	1	029B450.ZXH	YES	2000	MB	2000	YES	NO	NONE
029B1011ZXT	C E F	2	029B450.ZXH	NO	NONE	M6 FLANGE W/INSERT	2000	YES	NO	NONE
029B1012ZXT	B C E F	1	NO	YES	2000	MB	2000	YES	NO	NONE
029B1013ZXT	B C	1	029B175.ZXA	NO	NONE	M6 FLANGE	2000	NO	YES	2000
029B1014ZXT	A D	1	029B100.ZXEH	NO	NONE	NONE	NONE	YES	NO	NONE
029B1015ZXT	A C E	2	029B200.ZXEH	YES	2000 NOTE 1	MB	2000 NOTE 1	NO	NO	NONE
029B1016ZXT	C F	2	029B150.ZXEH	YES	2000 NOTE 1	MB	2000 NOTE 1	NO	NO	NONE
029B1017ZXT	A B C D E F	1	029B250.ZXA	NO	NONE	M6 FLANGE	2000	NO	NO	NONE

LTR	DATE	REVISION	CHK	APD
A	05/25/05	81735 - RELEASED	JJR	
B	06/15/06	B4405D - ADD CHART OPTIONS D, SLAB		
C	08/24/06	62094 - RELEASE 029B1020ZXT CHM		
D	01/02/07	85274D - REMOVE 029B1020ZXT FROM CHART DHM		
E	03/29/07	85414D - REDRAWN IN UG GMB		
F	08/31/07	000170EC/C - REMOVED USA FROM COVER		
G	04/24/08	000463EC/D - CHG. NOTES 1 & 4 GMB		
H	09/09/09	001246EC - ADDED NOTE #6 GMB		
J	9/18/13	509473ECA - SEE ECO	AGA	
K	02/06/14	510090ECA - ADD TN CHART PART NUMBER 029B250.ZXA	OPL	
L	05/02/14	510447ECA - CHANGE NOTE NUMBER FROM 6 TO 4.	AGA	

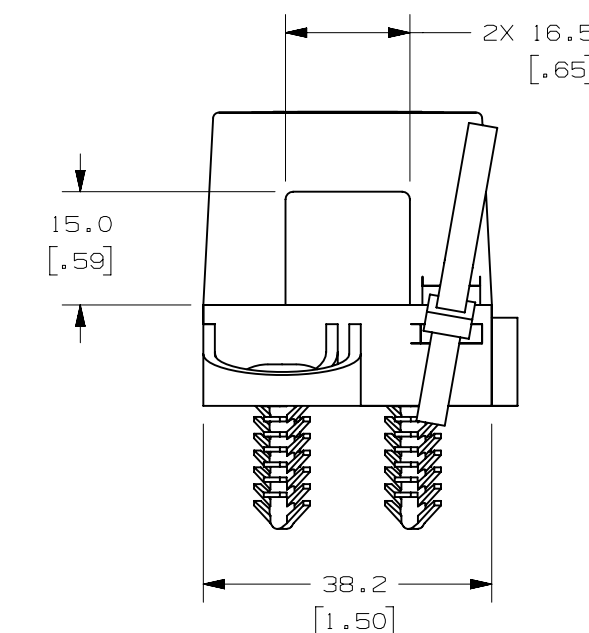
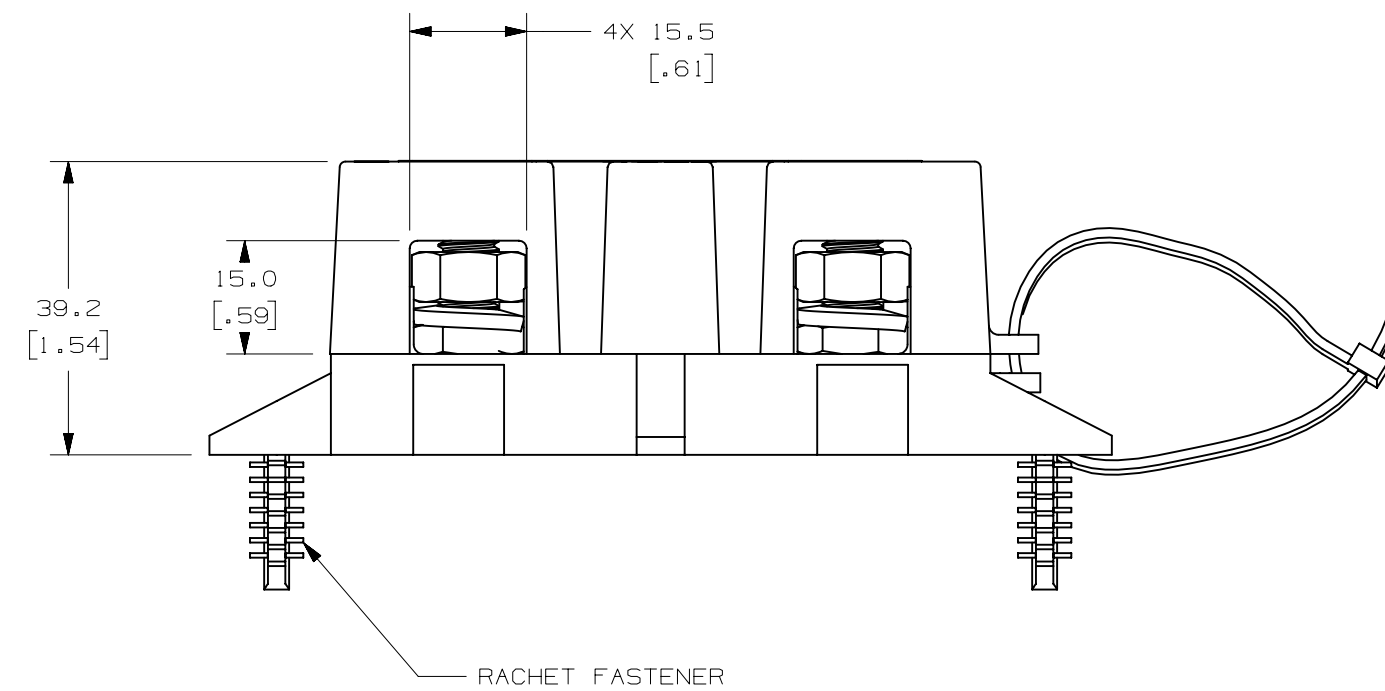
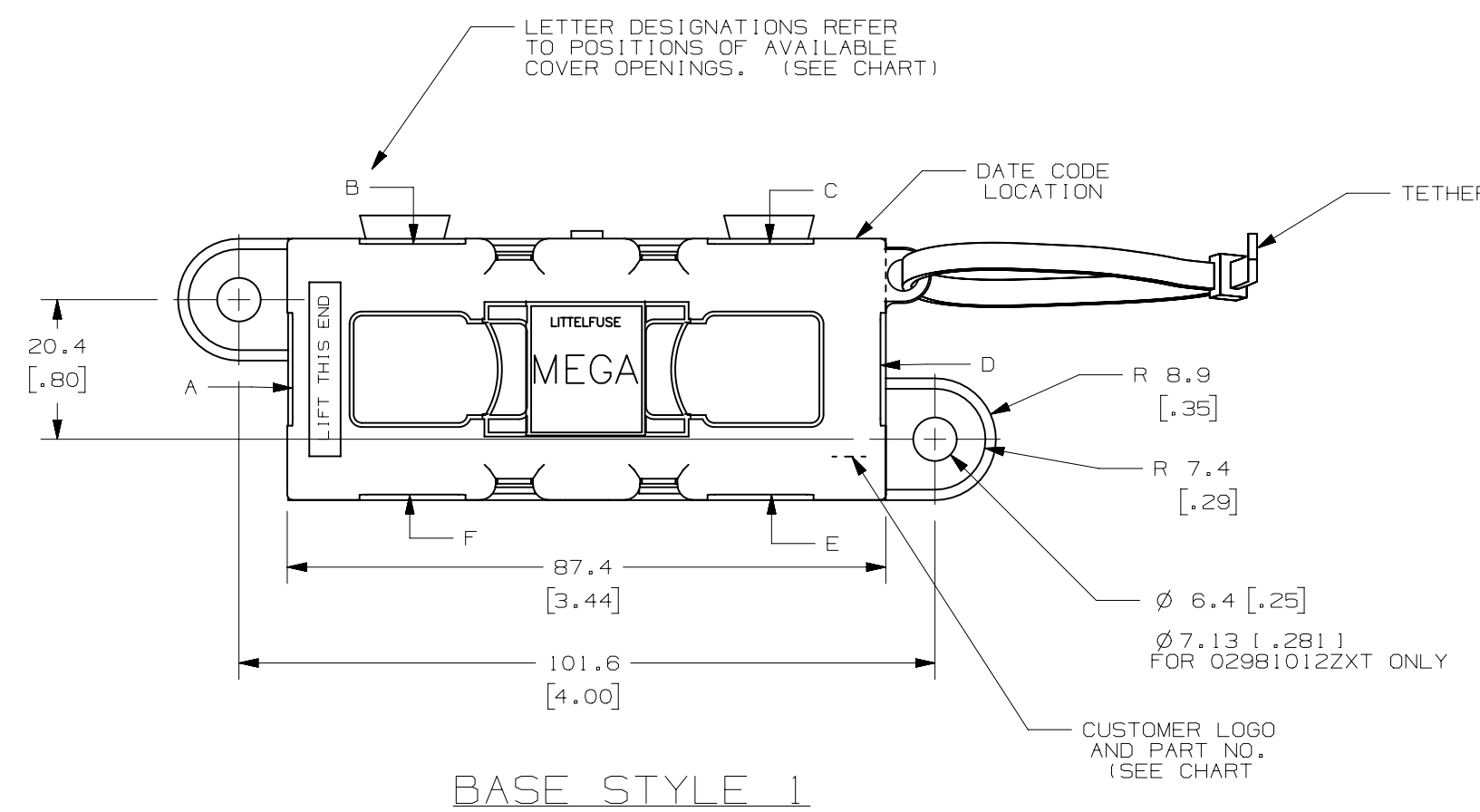
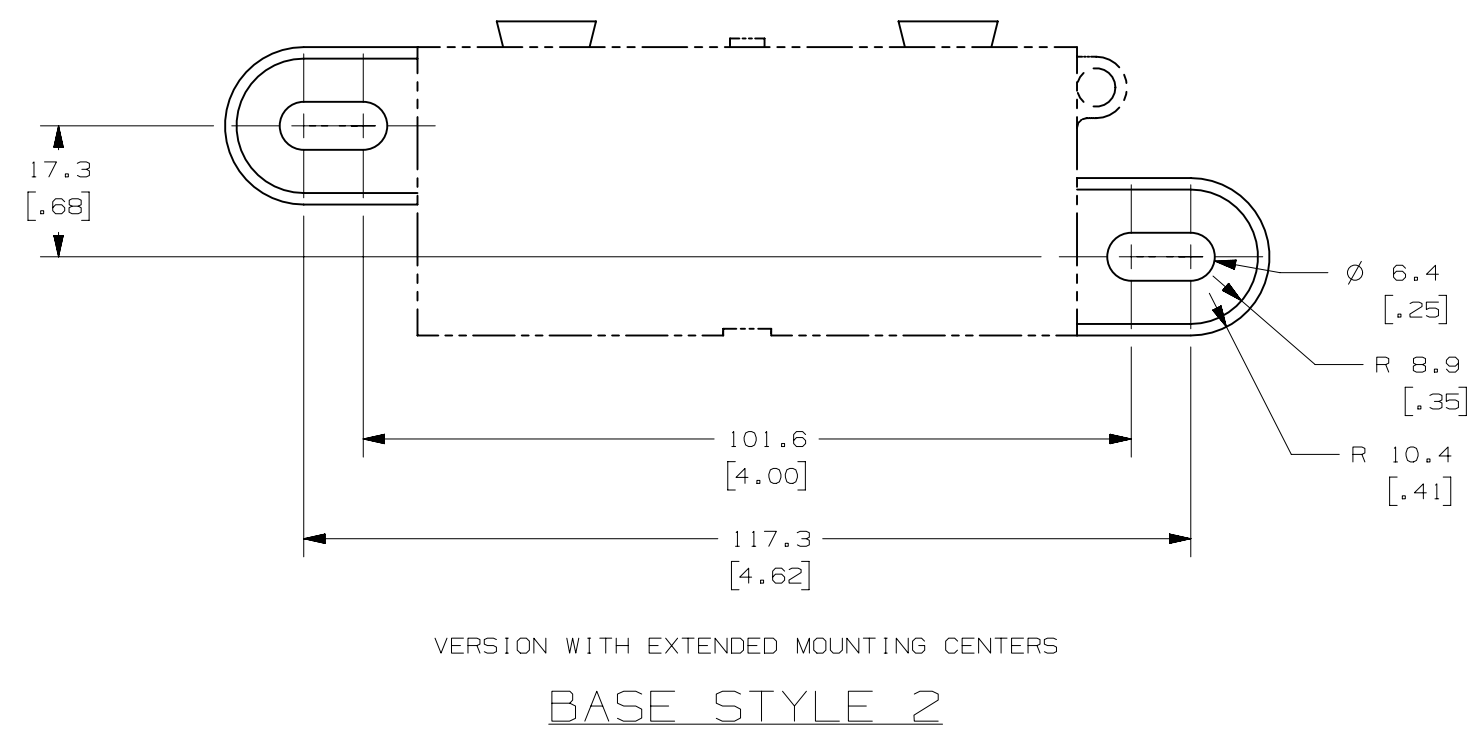
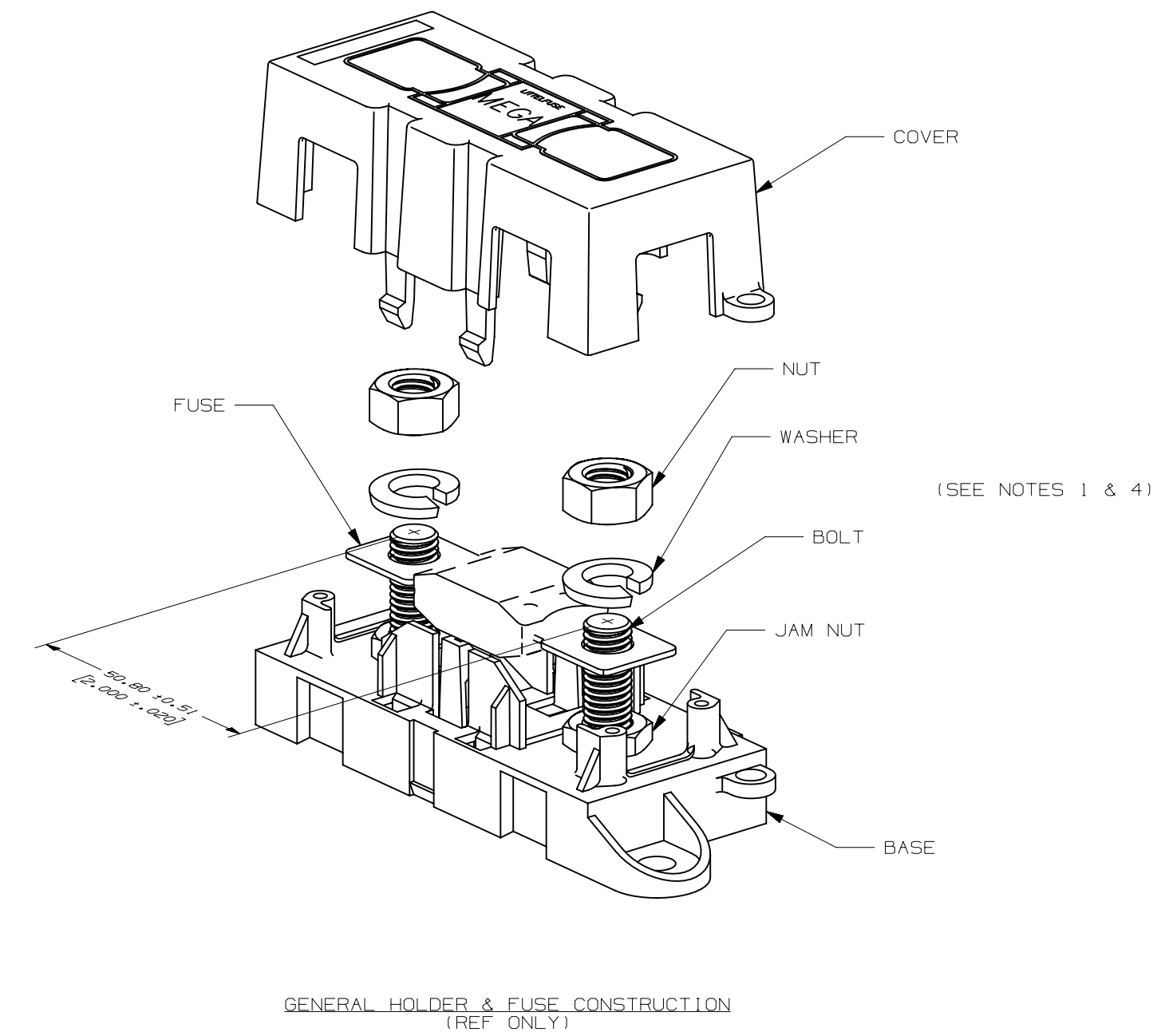

NOTE:

- NUTS TO BE ASSEMBLED BELOW STUD END NOT MORE THAN FINGERTIGHT WITH THE EXCEPTION OF 029B1015ZXT AND 029B1016ZXT WASHERS & HEX NUTS NOT TO BE ASSEMBLED TO BASE.
- COVER RETENTION TEST: MINIMUM FORCE OF 2 LBS. REQUIRED TO REMOVE COVER WHEN IT IS SUSPENDED UPSIDE DOWN. FORCE SHALL BE APPLIED THROUGH THE INNER HOLES (2) IN BASE, USE FIXTURE #T-C403 TO SUPPORT PART.
- MATERIALS:
 - BODY - GLASS FILLED THERMOPLASTIC COLOR - BLACK
 - COVER - THERMOPLASTIC COLOR - BLACK
 - WIRE TIE - THERMOPLASTIC COLOR - BLACK
 - STUDS & NUTS - M6 X 1.25 STEEL OR M6 X 1.0 STEEL AND STEEL LOCKWASHERS ARE ZINC PLATED WITH TRIVALENT CHROMATE, LEACHED & SEALED, INTEGRAL TORQUE CONTROL LUBRICANT FINISH. (MEETS 96 HR. ASTM STD. B-117 SALT SPRAY REQ.)
- TORQUE REQUIREMENTS FOR THE HEX NUT USED TO SECURE THE CUSTOMER RING TERMINAL TO THE MEGA FUSE TO BE:
 - 8mm NUT - 12-18 NEWTON METERS (106-159 IN-LBS)
 - 6mm NUT - 8-14 NEWTON METERS (71-124 IN-LBS)

THIS TORQUE IS NOT APPLIED IN THE FACTORY.
- HOLDER MEETS L/F VALIDATION TEST SPEC. VS-005002.
- HOLDER MOUNTING TORQUE - 5 NEWTON METERS (44 IN-LBS) MAX.

NO	COMPONENT NO	DESCRIPTION	QTY/M	U/M
BILL OF MATERIAL				
UNLESS OTHERWISE SPECIFIED, DIMENSIONS ARE IN MILLIMETERS. DIMENSIONS IN BRACKETS () ARE INCHES.				
UNLESS OTHERWISE SPECIFIED, DIMENSIONS DO NOT INCLUDE PLATING.				
⊙	DENOTES CRITICAL CHARACTERISTICS.			
CPK	DENOTES CPK DIMENSIONS. -MINIMUM CPK VALUE			
ST	DENOTES A CHARACTERISTIC THAT PROVIDES AN INDICATION OF PROCESS PERFORMANCE. PROCEDURE FOR MEASUREMENT AND TRACKING TO BE DEFINED IN LITTELFUSE INSPECTION INSTRUCTIONS			
CP	DENOTES CP DIMENSIONS. -MINIMUM CP VALUE MUST BE WITHIN THE DIMENSIONAL LIMITATIONS SHOWN ON DRAWING AND INITIALLY LOCATED TO ALLOW FOR MAXIMUM TOOL LIFE			
MATERIAL SPEC				
COPIES TO				
1	9	18	FINISH	
2	10	19		
3	12	20		
4	13	21	DRW	GLAB
5	14	23	DATE	05/25/05
6	15	33	SCALE	FULL
7	16	43	CHK	DATE
8	17	53	APPD	DATE
TOLERANCE UNLESS OTHERWISE SPECIFIED				
TWO PLACE DEC. +/- .25(.01)		FRACTION +/-		
THREE PLACE DEC. +/- .001(.004)		ANGULAR +/- .1°		
TITLE MEGAFUSE HOLDER				
REVISION DRWG. NO. OUTLINE				
L 029B1000ZXT SERIES				

METRIC



CAD GENERATED DRAWING - NO PENCIL CHANGES ALLOWED