

THIS DRAWING AND THE INFORMATION CONTAINED WITHIN IT ARE CONFIDENTIAL AND MAY NOT BE COPIED OR DISCLOSED WITHOUT THE WRITTEN PERMISSION OF LITTELFUSE.

| REVISIONS |                 |           |           |             |          |
|-----------|-----------------|-----------|-----------|-------------|----------|
| REV.      | DESCRIPTION     | DATE      | GCF / ECR | DESIGNED    | APPROVED |
| A         | Initial Release | 31-Jan-23 |           | L.Dal Molin | M.Tinto  |

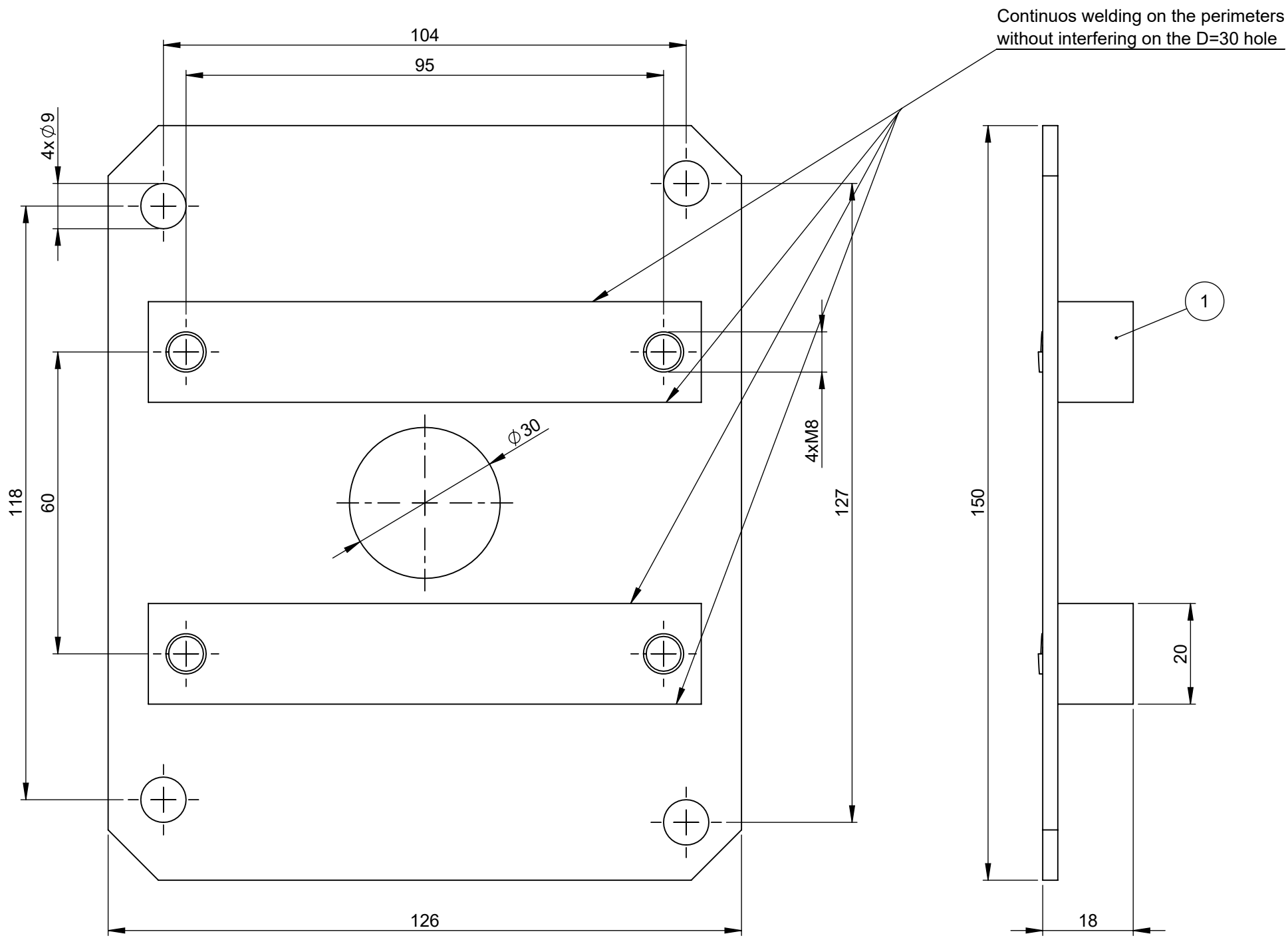

| 1    | Bracket     | Steel    | 1    |
|------|-------------|----------|------|
| POS. | DESCRIPTION | MATERIAL | Q.ty |
|      |             |          |      |

DIMENSIONS AND TOLERANCES IN MILLIMETERS, DEFINED ACCORDING TO ISO 1101-2017.

| linear dimensions |      |      |      |      |      |       |
|-------------------|------|------|------|------|------|-------|
| 0,5               | >3   | >6   | >30  | >120 | >400 | >1000 |
| 3                 | 6    | 30   | 120  | 400  | 1000 | 2000  |
| ±0,2              | ±0,3 | ±0,5 | ±0,8 | ±1,2 | ±2   | ±3    |

| angle (for range of lengths) |     |        |        |
|------------------------------|-----|--------|--------|
| up to                        | >10 | >50    | >120   |
| 10                           | 50  | 120    | 400    |
| ±1°30'                       | ±1° | ±0°30' | ±0°15' |

|     |   |
|-----|---|
| ●   | FIT/ FUNCTION CRITICAL CHARACTERISTICS SYMBOL   |
| <S> | SAFETY/ COMPLIANCE CRITICAL CHARACTERISTICS SYMBOL  |
| CPK | DENOTES CPK DIMENSIONS MINIMUM CPK VALUE  |
| ST  | DENOTES A CHARACTERISTIC THAT PROVIDES AN INDICATION OF PROCESS PERFORMANCE. PROCEDURE FOR MEASUREMENT AND TRACKING TO BE DEFINED IN LITTELFUSE INSPECTION INSTRUCTIONS |
| CP  | DENOTES CP DIMENSIONS, -MINIMUM CP VALUE MUST BE WITHIN THE DIMENSIONAL LIMITATIONS SHOWN ON DRAWING AND INITIALLY LOCATED TO ALLOW FOR MAXIMUM TOOL LIFE               |

|                              | NAME        | DATE        | <br><b>Expertise Applied   Answers Delivered</b> |                      |                |
|------------------------------|-------------|-------------|--|----------------------|----------------|
| DRAWN                        | L.Dal Molin | 31 Jan 2023 |  |                      |                |
| CHECKED                      | -           | -           |  |                      |                |
|                              | -           | -           |  |                      |                |
| FORM NO: CVP-PE40-0013 REV A |             |             | TITLE  |                      |                |
| FIRST ANGLE PROJECTION       |             |             | BRACKET FOR TGC/RMCDE                            |                      |                |
|                              |             |             | SIZE: A3   | DWG. NO. OL-00901400 | OUTLINE REV. A |
| DO NOT SCALE DRAWING         |             |             | SCALE 1:1  | SHEET 1 OF 1         |                |