

# LSR-XXX SERIES

## Load sensor

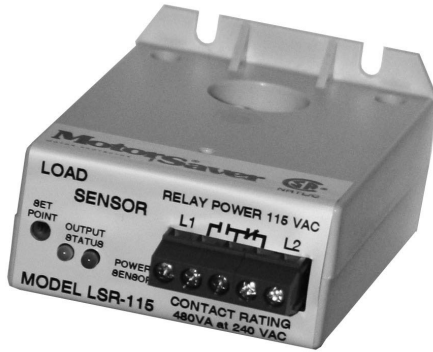

### Description

The LSR-xxx Series load sensors use current levels to determine feed rates, tool wear, loss of prime on pumps, mixer viscosity and all types of overload and underload conditions. They may also be used to stage pump motors, chillers and other machinery. These devices combine a current transformer (CT) with Form C (SPDT) relay contacts to switch alarm circuits, contactors or any resistive or inductive load. One simple screwdriver adjustment will calibrate the sensor for all single-phase or 3-phase applications up to 100hp.

### Features

- Can monitor current of motors up to 100Hp
- Fine adjustment with 20-turn pot
- Status LEDs

### Wiring Diagram

TYPICAL WIRING DIAGRAM FOR LOAD LOSS DETECTION

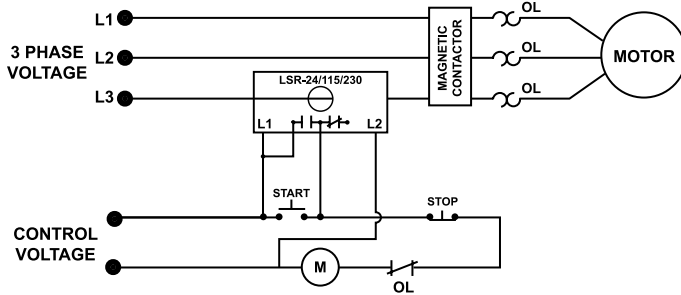

TYPICAL WIRING DIAGRAM FOR OVERLOAD DETECTION

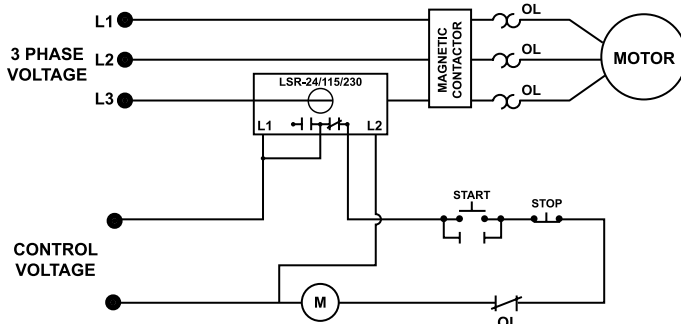

### Specifications

#### Functional Characteristics

- Isolation:** 600VAC rms
- Current Adjustment Range (Typical):** 2-100A
- Current Adjustment Range (Min-Max):** 0.5-135A
- Trip Setpoint:** Adjustable to ±1% range

#### Input Characteristics

- Control Power:**
  - LSR-24: 24VAC
  - LSR-115: 115VAC
  - LSR-230: 230VAC
- Max Current Ratings:** 135A max. continuous

#### Output Characteristics

- Output Contact Rating (SPDT):**
  - Pilot Duty: 480VA @ 240VAC
  - General Purpose: 10A
- General Characteristics:**
  - Temperature Range:** -20° to 70°C (-4° to 158°F)
  - Wire Size:** #12-24AWG
  - Hole Size:** 0.725" diameter
  - Terminal Torque:** 7 in.-lbs.

#### Safety Marks

- CSA, CSA-NRTL/C:** (File #46510)
- CE:** IEC 60947

- Dimensions:**
  - H:** 42.42 mm (1.67"); **W:** 58.42 mm (2.3"); **D:** 90.43 mm (3.56")
- Weight:** 0.4 lb. (6.4 oz., 181.44 g)
- Mounting Method:** Four #6 screws 3/4" in length

**Caution:** This product should not be relied upon solely for safety of life or safety applications.

### Ordering Information

MODEL	LINE VOTAGE
LSR-24	24VAC