

PART NUMBER	UPC CODE
LM32003DJ	07945831085

REVISION		
REV	DATE	DESCRIPTION
A	5/4/23	526430GCP - RELEASE PER EM3380 MRY
B	4/15/24	527548ECP/C - UPDATE WIRE RANGE IN SIDE PRINTING MRY

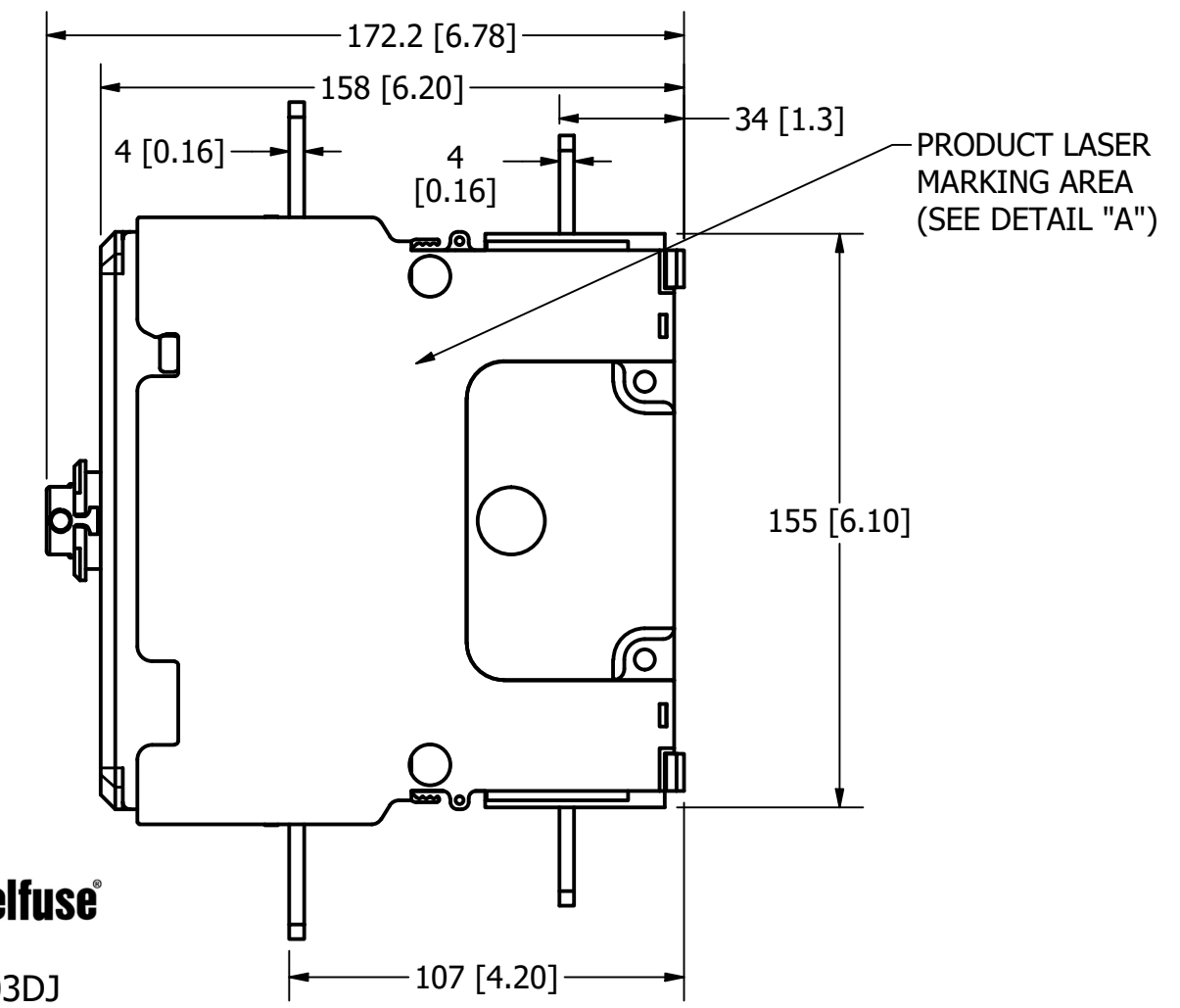

LM32003DJ
 L: 0123456789; NS: 01234
 UL 98
 600Vac 200A 50/60Hz
 General purpose switch
Use Cu wire only
 75°C 3/0AWG - 300MCM Wire
 Terminal Torque 159 LB.IN.
 With KIT Terminal Lugs LDM3TLU11
 Motor-Circuit Switch

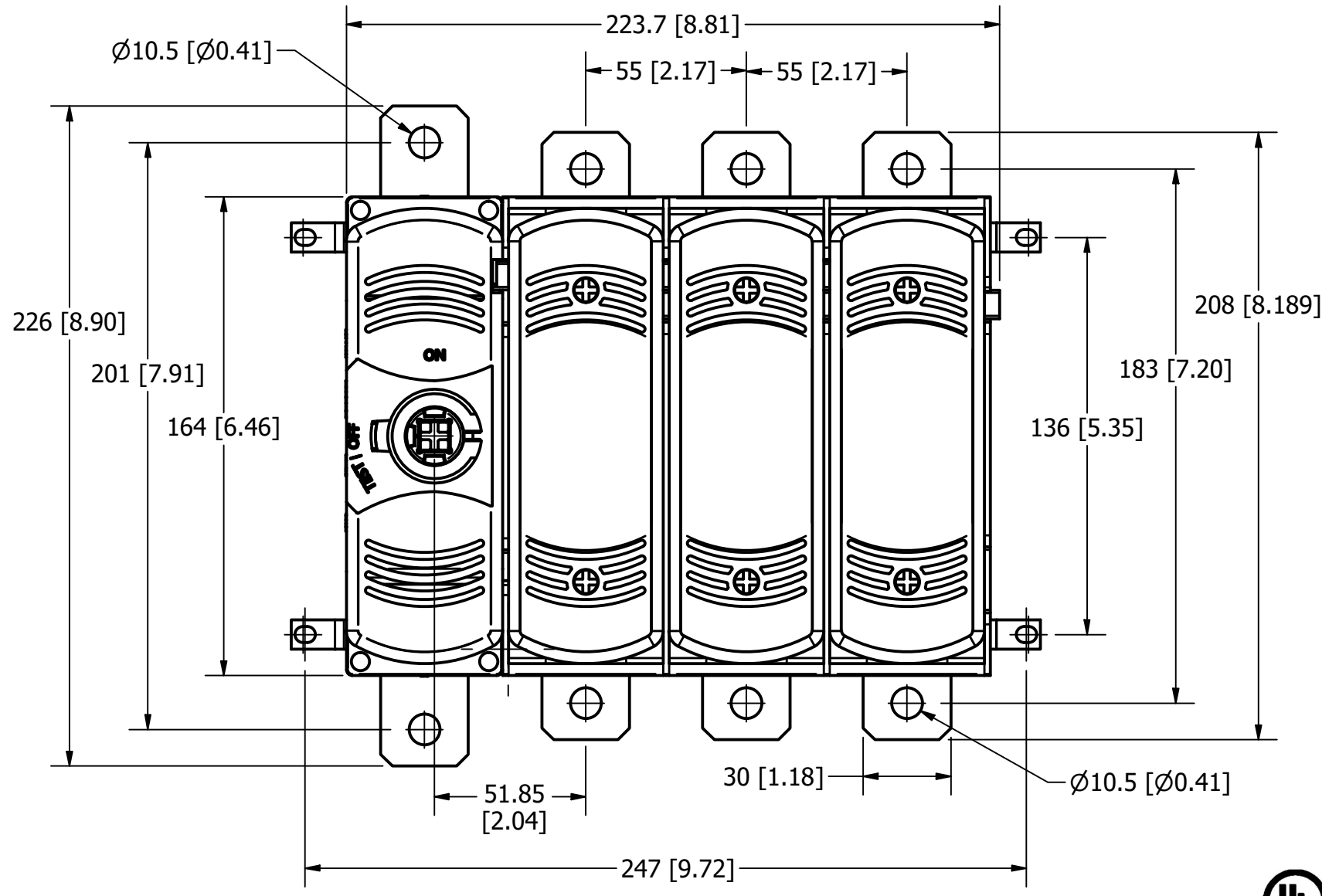
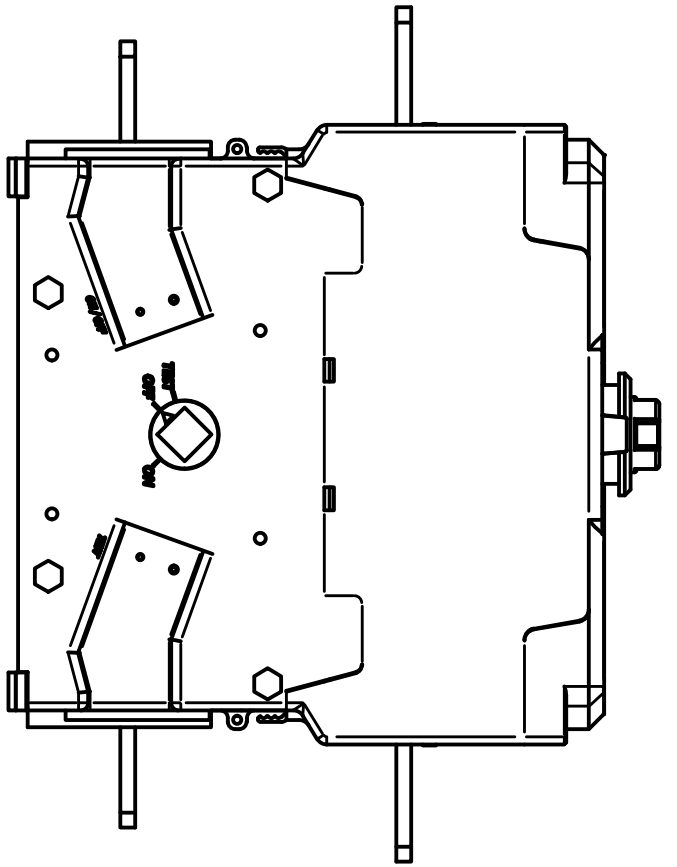
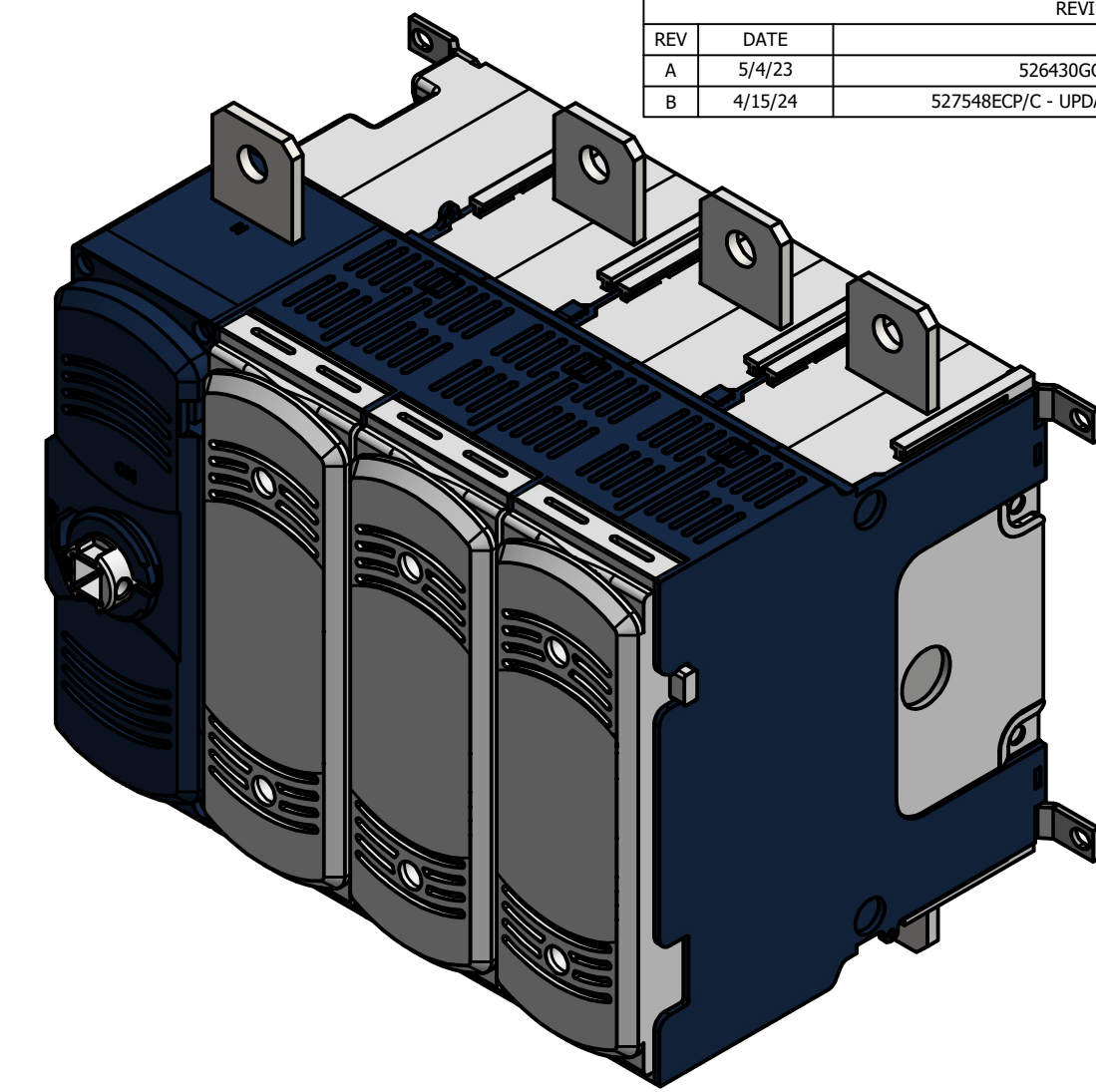
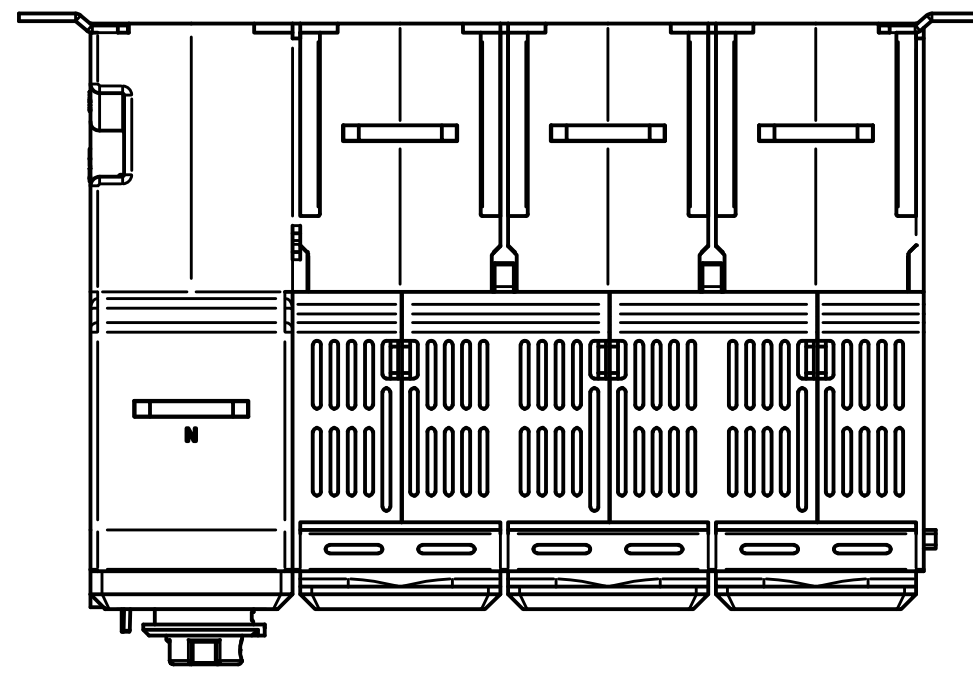

3 \varnothing	Vac	240	480	600
MAX	HP	50	100	125
STD	HP	25	50	60

Suitable for use on a circuit capable of delivering not more than 200kA R.M.S symmetrical, 600V max. Use class J fuses.

Max. fuse size **200A**

The starting current of motors of more than the standard horsepower ratings may require the use of fuses with appropriate time-delay characteristics.

Continuous load current not to exceed 80 percent of the rating of the fuses employed in other than motor circuits.

Not for use as a motor controller.

Use accessories according to instructions: 45672011

MADE IN SPAIN

DETAIL "A"
SIDE PRINTING

1	NO	COMPONENT NO	DESCRIPTION	QTY/M	U/M
BILL OF MATERIAL					
<S>			CRITICAL CHARACTERISTIC FOR PART SAFETY/COMPLIANCE		
●			DENOTES CRITICAL CHARACTERISTICS.		
CPK			DENOTES CPK DIMENSIONS, -MINIMUM CPK VALUE		
(ST)			DENOTES A CHARACTERISTIC THAT PROVIDES AN INDICATION OF PROCESS PERFORMANCE. PROCEDURE FOR MEASUREMENT AND TRACKING TO BE DEFINED IN LITTELFUSE INSPECTION INSTRUCTIONS.		
CP			DENOTES CP DIMENSIONS, -MINIMUM CP VALUE MUST BE WITHIN THE DIMENSIONAL LIMITATIONS SHOWN ON DRAWING AND INITIALLY LOCATED TO ALLOW FOR MAXIMUM TOOL LIFE.		C
MATL SPEC			FINISH		
DRW	myork	DATE	12/31/1969	SCALE	NTS
			FINISH GOOD WT		GRAMS/PIECE
UNLESS OTHERWISE SPECIFIED, DIMENSIONS ARE IN MILLIMETERS, DIMENSIONS IN BRACKETS [] ARE INCHES DIMENSIONING AND DO NOT INCLUDE PLATING. TOLERANCING TO BE INTERPRETED IN ACCORDANCE WITH ANSI Y14.5M-1994					
3RD ANGLE PROJECTION					
TITLE CLASS J 200A DISCONNECT 3P WITH DETACHABLE NEUTRAL OUTLINE					
Littelfuse CHICAGO, ILLINOIS 60631			REVISION	DRWG NO.	SHEET 1 OF 1
			B	OL-LM32003DJ	