

QVxx12xHx Series

12 A High Temperature Alternistor TRIACs

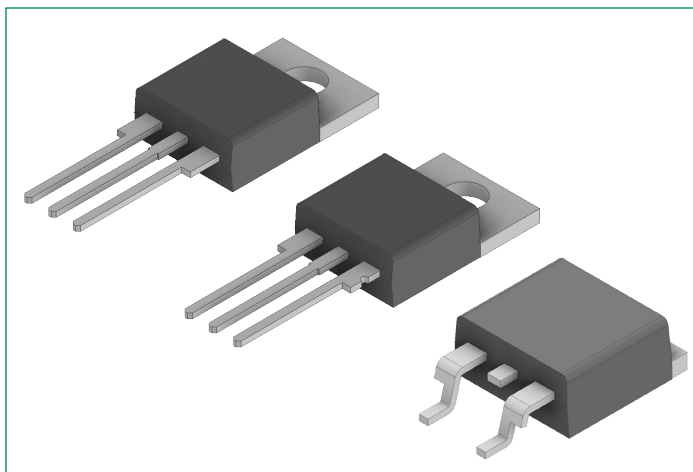

Pinout Diagram

TO-220 (L-Package)

Tab (Isolated)

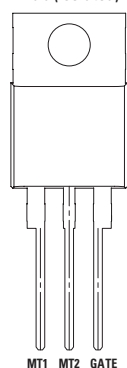

TO-220 (R-Package)

Tab (Non-isolated)
MT2

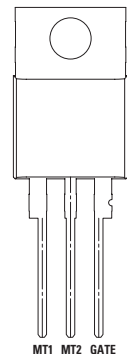

TO-263

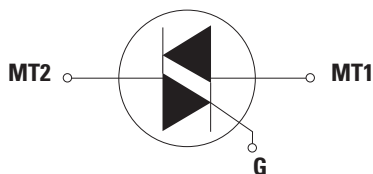
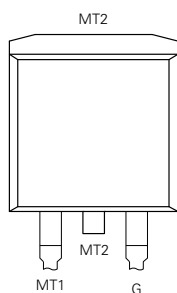

MT1: Main Terminal 1; **MT2:** Main Terminal 2; **G:** Gate

Description:

This 12 A high temperature Alternistor TRIAC, offered in TO-220AB, TO-220 isolated, and TO-263 packages, has 150°C maximum junction temperature (T_{vj}) and 153 A I_{TSM} (60 Hz).

This series enables easier thermal management and higher surge handling capability in AC power control applications such as heater control, motor speed control, lighting controls, and static switching relays.

This QV series TRIAC operates in quadrants I, II, and III, and offers high performance in applications requiring high commutation capability without a snubber circuit.

Features:

- Voltage capability of 600 V
- Surge capability of 153 A at 60 Hz half cycle
- Mechanically and thermally robust TO-220 clip-attach assembly
- High dv/dt up to 2000 V/ μ s for improved noise immunity
- 3Q technology for high commutation capability
- Internally-isolated TO-220 package
- Maximum T_{vj} of 150°C
- Halogen-free and RoHS-compliant
- Recognized to UL 1557 as an Electrically Isolated Semiconductor Device (L package: file number E71639)

Applications:

TRIAC is an excellent AC switch in applications such as heating, lighting, and motor speed controls.

Typical applications are:

- Heater control such as coffee brewer, tankless water heater, and infrared heater
- AC solid-state relays
- Light dimmers including incandescent and LED lighting
- Motor speed control in kitchen appliances, power tools, home/brown/white goods and light industrial applications such as compressor motor control

Alternistor TRIAC is used with high inductive loads requiring high commutation capability. Internally isolated packages offer better heat sinking with higher isolation voltage.

Product Summary

Characteristic	Value	Unit
$I_{T(RMS)}$	12	A
V_{DRM}/V_{RRM}	600	V
$I_{GT(Q1)}$	35 or 50	mA

Maximum Ratings - Alternistor TRIAC (3 Quadrants)

Symbol	Characteristics	Conditions			Value	Units
$I_{T(RMS)}$	On-state RMS Current	QVxx12LHy	$T_C = 120^\circ\text{C}$	full sine wave	12	A
		QVxx12RH y / QVxx12NH y	$T_C = 135^\circ\text{C}$			
I_{TSM}	Non-repetitive Surge Peak On-state Current	f = 50 Hz, t = 20 ms, full cycle, T_{vj} initial = 25°C			140	A
		f = 60 Hz, t = 16.7 ms, full cycle, T_{vj} initial = 25°C			153	
I^2t	I^2t Value for Fusing	$t_p = 8.3$ ms			97	A ² s
di/dt	Critical Rate of Rise of On-state Current	f = 60 Hz, $T_{vj} = 150^\circ\text{C}$			100	A/ μ s
I_{GTM}	Peak Gate Trigger Current	$t_p \leq 10 \mu\text{s}$, $I_{GT} \leq I_{GTM}$, $T_{vj} = 150^\circ\text{C}$			4	A
$P_{G(AV)}$	Average Gate Power Dissipation	$T_{vj} = 150^\circ\text{C}$			0.5	W
T_{stg}	Storage Temperature Range	-			-40 to 150	°C
T_{vj}	Operating Junction Temperature Range	-			-40 to 150	°C
V_{DSM}/V_{RSM}	Non-repetitive Surge Peak Off-state Voltage	$V_{DRM} = 600$ V, pulse width = 100 μ s			$V_{DSM}/V_{RSM} + 100$	V

xx = voltage/10; y = sensitivity

Electrical Characteristics ($T_{vj} = 25^\circ\text{C}$, unless otherwise specified) – **Alternistor TRIAC** (3 Quadrants)

Symbol	Characteristics	Conditions	QVxx12xH4			QVxx12xH5			Units	
			Min.	Typ.	Max.	Min.	Typ.	Max.		
I_{GT}	DC Gate Trigger Current	$V_D = 12$ V, $R_L = 60 \Omega$	I – II – II	-	-	35	-	-	50	mA
V_{GT}	DC Gate Trigger Voltage		I – II – II	-	-	1.2	-	-	1.2	V
V_{GD}	Gate Non-trigger Voltage	$V_D = V_{DRM}$, $R_L = 3.3$ k Ω , $T_{vj} = 150^\circ\text{C}$	I – II – II	0.15	-	-	0.15	-	-	V
I_H	Holding Current	$I_T = 100$ mA		-	-	50	-	-	60	mA
dv/dt	Critical Rate-of-rise of Off-stage Voltage	$V_D = V_{DRM}$, Gate Open, $T_{vj} = 150^\circ\text{C}$		500	-	-	750	-	-	V/ μ s
		$V_D = 2/3 V_{DRM}$, Gate Open, $T_{vj} = 150^\circ\text{C}$		1000	-	-	1000	-	-	
(dv/dt)c	Critical Rate-of-rise of Commutation Voltage	(di/dt)c = 8.6 A/ms, $T_{vj} = 150^\circ\text{C}$		50	-	-	50	-	-	V/ μ s
t_{gt}	Turn-on Time	$I_G = 2 \times I_{GT}$, $P_W = 15 \mu\text{s}$, $I_T = 22.6$ A _{pk}	I	-	1	-	-	1	-	μ s
			II	-	2	-	-	2	-	
			III	-	7	-	-	10	-	

xx = voltage/10; y = sensitivity

Thermal Characteristics

Symbol	Characteristics	Value	Units
R_{thJC}	Thermal Resistance, Junction to Case (AC)	QVxx12RH y / QVxx12NH y	0.9
		QVxx12LHy	1.85

Static Characteristics

Symbol	Characteristics	Conditions	Value	Units
V_{TM}	Peak On-state Voltage	$I_T = 17$ A $t_p = 380 \mu\text{s}$	1.6	V
I_{DRM}/I_{RRM}	Off-state Current, Peak Repetitive	$V_D = V_{DRM}/V_{RRM}$, $T_{vj} = 25^\circ\text{C}$	5	μ A
		$V_D = V_{DRM}/V_{RRM}$, $T_{vj} = 150^\circ\text{C}$, $V_{DRM} = 600$ V	4	mA
V_{T0}	Threshold Voltage	$T_{vj} = 150^\circ\text{C}$	0.85	V
R_D	Slope Resistance	$T_{vj} = 150^\circ\text{C}$	23	m Ω

Characteristic Curves

Figure 1. Definition of Quadrants

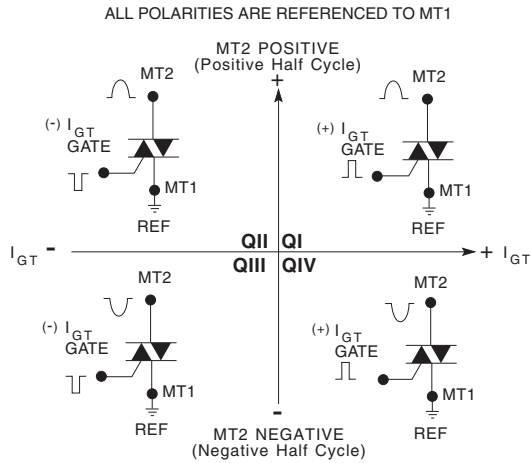

Note: Alternistors will not operate in QIV

Fig. 2. Normalized DC Gate Trigger Current for all Quadrants vs. Junction Temperature

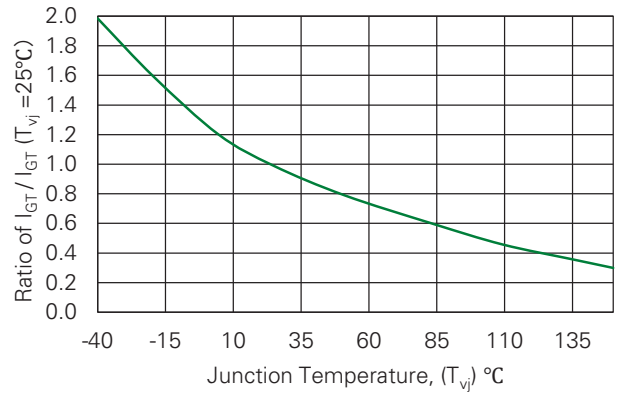

Fig. 3. Normalized DC Holding Current vs. Junction Temperature

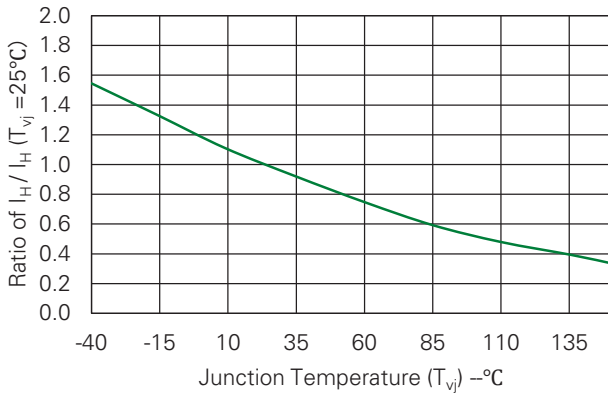

Fig. 4. Normalized DC Gate Trigger Voltage for all Quadrants vs. Junction Temperature

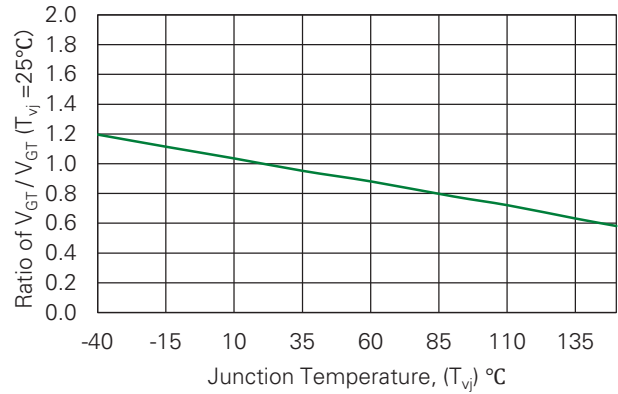

Fig. 5. Typical Power Dissipation vs. RMS On-state Current

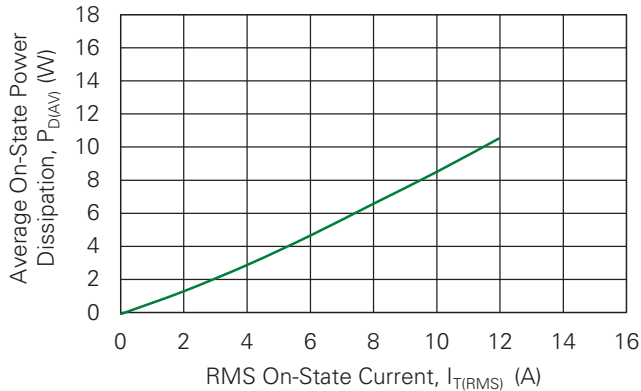

Fig. 6. Typical On-state Current vs. On-state Voltage

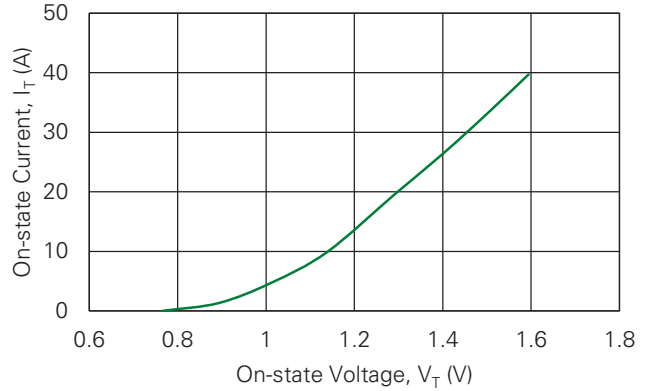

Fig. 7. Maximum Allowable Case Temperature vs. RMS On-state Current

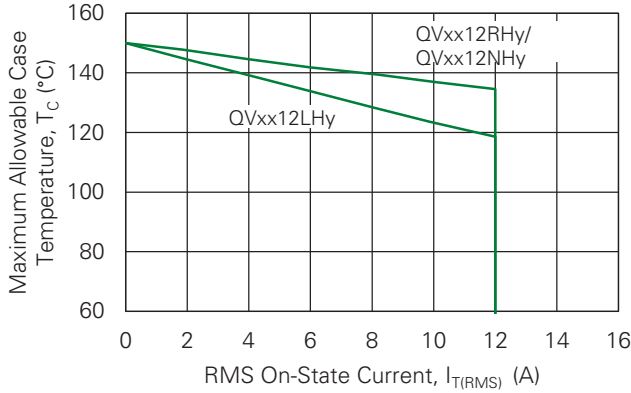
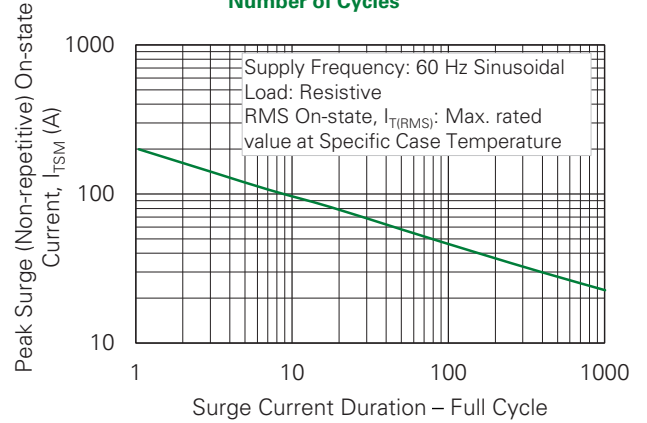

Fig. 8. Surge Peak On-state Current vs. Number of Cycles



Notes:

1. Gate control may be lost during and immediately following surge current interval.
2. Overload may not be repeated until junction temperature has returned to steady-state rated value.

Soldering Parameters

Characteristic		Value
Reflow Condition		Pb – Free assembly
Pre-heat	Temperature Min ($T_{s(min)}$)	150°C
	Temperature Max ($T_{s(max)}$)	200°C
	Time (min to max) (t_s)	60 – 180 secs
Average ramp up rate (Liquidus Temp)(T_L) to peak		5°C/second max
$T_{s(max)}$ to T_L - Ramp-up Rate		5°C/second max
Reflow	Temperature (T_L) (Liquidus)	217°C
	Time (t_L)	60 – 150 seconds
Peak Temperature (T_p)		260 ^{+0/5} °C
Time within 5°C of actual peak Temperature (t_p)		20 – 40 seconds
Ramp-down Rate		5°C/second max
Time 25°C to peak Temperature (T_p)		8 minutes max
Do Not Exceed		260°C

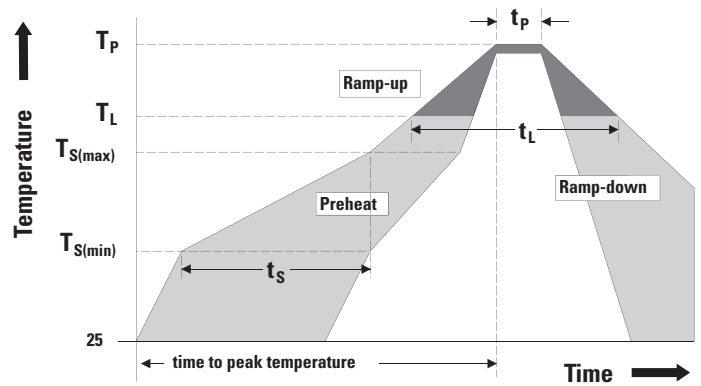

Physical Specifications

Characteristic	Value
Terminal Finish	100% Matte Tin-plated
Body Material	UL Recognized compound meeting flammability rating 94 V-0
Terminal Material	Copper Alloy

Environmental Specifications

Test	Specifications and Conditions
AC Blocking	MIL-STD-750, M-1040, Cond A Applied Peak AC voltage @ 150°C for 1008 hours
Temperature/Humidity	EIA / JEDEC, JESD22-A101, 1008 hours; 160 V - DC: 85°C; 85% relative humidity
Temperature Cycling	MIL-STD-750, M-1051, 1000 cycles; -55°C to +150°C; 15-min dwell-time
Resistance to Solder Heat	MIL-STD-750: Method 2031
Solderability	ANSI/J-STD-002: category 3, Test A
Lead Bend	MIL-STD-750, M-2036 Cond E
Moisture Sensitivity Level	Level 1, JEDEC-J-STD-020
UHASt	JESD22A-118, 96 hrs, 130°C/ 85% RH
IOL	MIL-STD-750 Method 1037

Design Considerations

Careful selection of the correct component for the application's operating parameters and environment will go a long way toward extending the operating life of the Thyristor. Good design practice should limit the maximum continuous current through the main terminals to 75% of the component rating. Other ways to ensure long life for a power discrete semiconductor are proper heat sinking and selection of voltage ratings for worst case conditions. Overheating, overvoltage (including dv/dt), and surge currents are the main killers of semiconductors. Correct mounting, soldering, and forming of the leads also help protect against component damage.

Product Selector

Part Number	Voltage	Gate Sensitivity Quadrants	Type	Package
	600 V	I-II-III		
QVxx12LH4	X	35 mA	Alternistor TRIAC	TO-220AB (L package)
QVxx12RH4	X	35 mA	Alternistor TRIAC	TO-220AB (R package)
QVxx12NH4	X	35 mA	Alternistor TRIAC	TO-263 (D ² PAK)
QVxx12LH5	X	50 mA	Alternistor TRIAC	TO-220AB (L package)
QVxx12RH5	X	50 mA	Alternistor TRIAC	TO-220AB (R package)
QVxx12NH5	X	50 mA	Alternistor TRIAC	TO-263 (D ² PAK)

Packing Options

Part Number	Marking	Weight	Packing Mode	Base Quantity
QVxx12LHyTP	QVxx12LHy	2.2 g	Tube Pack	1000
QVxx12RH _y TP	QVxx12RH _y	2.2 g	Tube Pack	1000
QVxx12NH _y TP	QVxx12NH _y	1.6 g	Tube Pack	1000
QVxx12NH _y RP	QVxx12NH _y	1.6 g	Embossed Carrier	500

Part Numbering and Marking

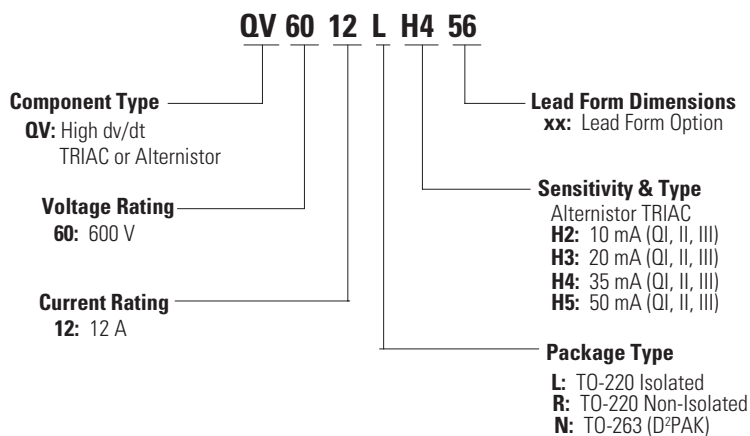

TO-220 AB - (L and R Package)
 TO-263 - (N Package)

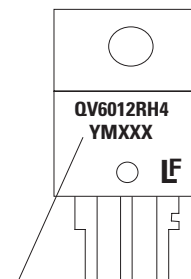

Date Code Marking
Y: Year Code
M: Month Code
XXX: Lot Trace Code

Package Dimensions TO-220AB (L-Package) – Isolated Mounting Tab

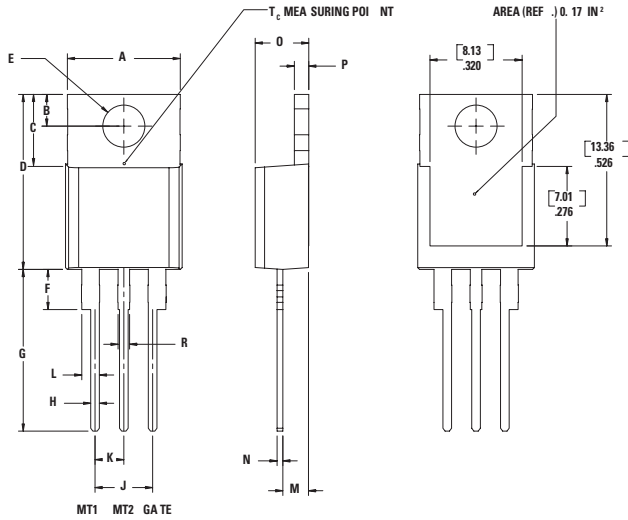

Note: Maximum torque to be applied to mounting tab is 8 in-lbs. (0.904 Nm).

Symbol	Millimeters		Inches	
	Min.	Max.	Min.	Max
A	9.65	10.67	0.380	0.420
B	2.67	2.92	0.105	0.115
C	5.84	6.35	0.230	0.250
D	14.99	15.75	0.590	0.620
E	3.61	3.73	0.142	0.147
F	2.79	3.30	0.110	0.130
G	13.72	14.60	0.540	0.575
H	0.64	0.89	0.025	0.035
J	4.95	5.21	0.195	0.205
K	2.41	2.67	0.095	0.105
L	1.52	1.91	0.060	0.075
M	2.16	2.41	0.085	0.095
N	0.46	0.61	0.018	0.024
O	4.52	4.78	0.178	0.188
P	1.14	1.52	0.045	0.060
R	0.97	1.22	0.038	0.048

Package Dimensions TO-220AB (R Package) – Non-isolated Mounting Tab Common with Center Lead

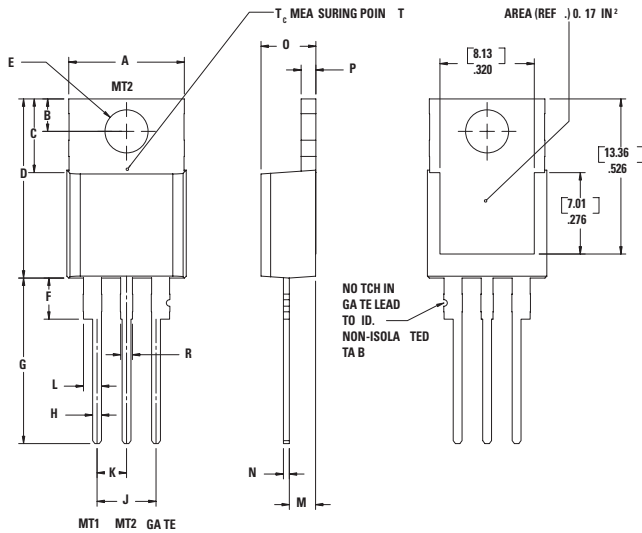

Note: Maximum torque to be applied to mounting tab is 8 in-lbs. (0.904 Nm).

Symbol	Millimeters		Inches	
	Min.	Max.	Min.	Max
A	9.65	10.67	0.380	0.420
B	2.67	2.92	0.105	0.115
C	5.84	6.35	0.230	0.250
D	14.99	15.75	0.590	0.620
E	3.61	3.73	0.142	0.147
F	2.79	3.30	0.110	0.130
G	13.72	14.60	0.540	0.575
H	0.64	0.89	0.025	0.035
J	4.95	5.21	0.195	0.205
K	2.41	2.67	0.095	0.105
L	1.52	1.91	0.060	0.075
M	2.16	2.41	0.085	0.095
N	0.46	0.61	0.018	0.024
O	4.52	4.78	0.178	0.188
P	1.14	1.52	0.045	0.060
R	0.97	1.22	0.038	0.048

Package Dimensions TO-263 (N Package) – D²PAK Surface Mount

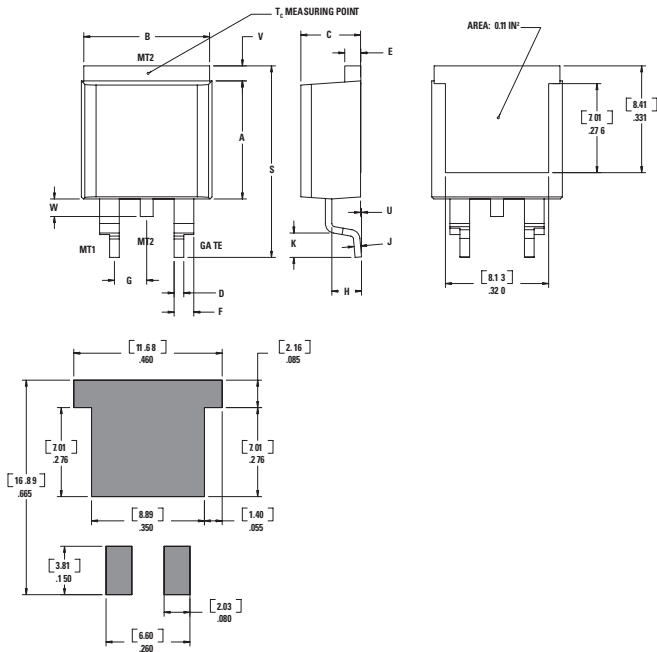

Symbol	Millimeters		Inches	
	Min.	Max.	Min.	Max
A	9.14	9.40	0.360	0.370
B	9.65	10.67	0.380	0.420
C	4.52	4.78	0.178	0.188
D	0.64	0.89	0.025	0.035
E	1.14	1.52	0.045	0.060
F	1.52	1.91	0.060	0.075
G	2.41	2.67	0.095	0.105
H	2.34	2.59	0.092	0.102
J	0.46	0.61	0.018	0.024
K	2.29	2.79	0.090	0.110
S	14.99	15.88	0.590	0.625
V	0.89	1.14	0.035	0.045
U	0.05	0.25	0.002	0.010
W	1.02	1.78	0.040	0.070

Reel Pack (RP) Specifications for TO-263 Embossed Carrier

Meets all EIA-481-2 Standards

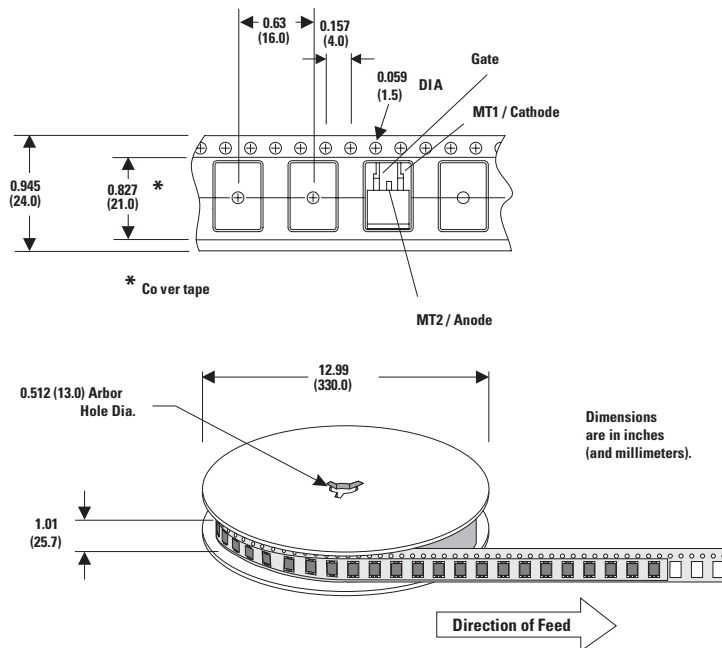

Disclaimer Notice

Information furnished is believed to be accurate and reliable. However, users should independently evaluate the suitability of and test each product selected for their own applications. Littelfuse products are not designed for, and may not be used in, all applications. Read complete Disclaimer Notice at <http://www.littelfuse.com/disclaimer-electronics>.



Part of:

