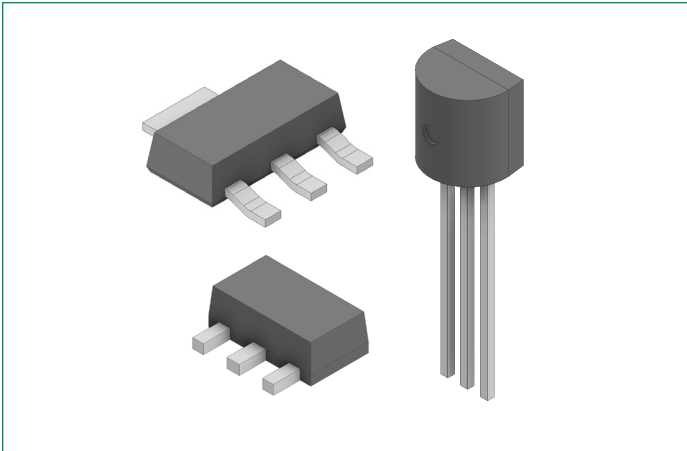

LX8 Series

EV Series 0.8 A Sensitive TRIACs

HF RoHS

Description:

The LX8 is a solid state switch series offering direct interface to microprocessor drivers in economical TO-92 and surface mount packages. The die voltage blocking junctions are glass-passivated to ensure long term reliability and parametric stability.

Features:

- RoHS compliant and halogen-free
- Through-hole and surface mount packages
- Static $dv/dt > 10 \text{ V}/\mu\text{s}$
- Blocking voltage (V_{DRM}) capability up to 600 V
- Surge current capability $> 9.5 \text{ A}$

Pinout Diagram

SOT-223

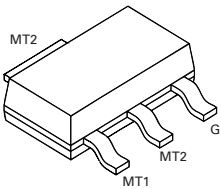

SOT-89

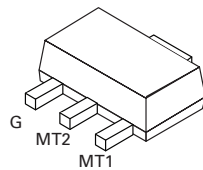

TO-92

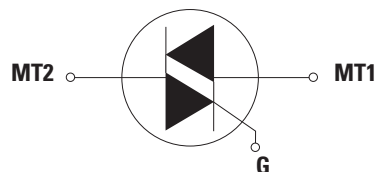
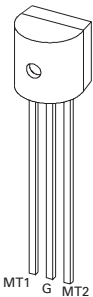

Applications:

The LX8 EV Series is especially designed for low current applications such as heating controls in hair care products, as well as replacement of mechanical switch contacts where long life is required.

Product Summary

Characteristic	Value	Unit
$I_{\text{T(RMS)}}$	0.8	A
$V_{\text{DRM}}/V_{\text{RRM}}$	400 to 600	V
I_{GT}	3 to 5	mA

MT1: Main Terminal 1; **MT2:** Main Terminal 2; **G:** Gate

Maximum Ratings

Symbol	Characteristics	Conditions			Value	Units
$I_{T(RMS)}$	On-state RMS Current	TO-92	$T_C = 50\text{ }^\circ\text{C}$	Full sine wave	0.8	A
		SOT-89	$T_C = 60\text{ }^\circ\text{C}$			
		SOT-223	$T_L = 90\text{ }^\circ\text{C}$			
I_{TSM}	Non-repetitive Surge Peak On-state Current	f = 50 Hz		T_{vj} initial = 25 °C, Single cycle	8	A
		f = 60 Hz			9.5	
I^2t	I^2t Value for Fusing	$t_p = 10\text{ ms}$			0.32	A ² s
		$t_p = 8.3\text{ ms}$			0.37	
di/dt	Critical Rate of Rise of On-state Current	–			20	A/μs
I_{GM}	Peak Gate Current	$t_p = 10\text{ }^\mu\text{s}$			1	A
$P_{G(AV)}$	Average Gate Power Dissipation	–			0.1	W
T_{stg}	Storage Temperature Range	–			–40 to 150	°C
T_{vj}	Virtual Junction Temperature Range	–			–40 to 110	°C

Electrical Characteristics ($T_{vj} = 25\text{ }^\circ\text{C}$, unless otherwise specified)

Symbol	Characteristics	Conditions	Quadrant	Limit	Value		Units
					LX803xy	LX807xy	
I_{GT}	DC Gate Trigger Current	$V_D = 12\text{ V}, R_L = 60\text{ }^\Omega$	I – II – III	Max.	3	5	mA
			IV	Max.	5	7	
V_{GT}	DC Gate Trigger Voltage	$V_D = 12\text{ V}, R_L = 60\text{ }^\Omega$	All quadrants	Max.	1.3		V
I_H	Holding Current	Gate Open		Max.	5		mA
$(dv/dt)_{cr}$	Critical Rate-of-rise of Off-stage Voltage	$T_{vj} = 110\text{ }^\circ\text{C}, V_D = V_{DRM}$, Exponential Waveform, Gate Open		Min.	10		V/μs
$(dv/dt)_c$	Critical Rate-of-rise of Commutating Voltage	$(di/dt)_c = 0.43\text{ A/ms}, T_{vj} = 110\text{ }^\circ\text{C}$		Min.	1.5		V/μs
t_{gt}	Turn-on Time	$I_G = 25\text{ mA}, P_W = 15\text{ }^\mu\text{s}, I_T = 1.2\text{ A}_{pk}$		Max.	2.0		μs

Note: x = voltage, y = package

Static Characteristics ($T_{vj} = 25\text{ }^\circ\text{C}$, unless otherwise specified)

Symbol	Characteristics	Conditions	Maximum Value	Units
V_{TM}	Peak On-state Voltage	$I_T = 1.13\text{ A}_{pk}$	1.60	V
I_{DRM}	Off-state Current, Peak Repetitive	$V_D = V_{DRM}, T_{vj} = 25\text{ }^\circ\text{C}$	5	μA
		$V_D = V_{DRM}, T_{vj} = 110\text{ }^\circ\text{C}$	100	

Thermal Characteristics

Symbol	Characteristics	Conditions	Value	Units	
R_{thJC}	Thermal Resistance, Junction to Case (AC)	$I_T = 0.8\text{ A}_{(RMS)}$ ¹	TO-92	60	K/W
			SOT-89	50	
			SOT-223	25	
R_{thJA}	Thermal Resistance, Junction to Ambient	$I_T = 0.8\text{ A}_{(RMS)}$ ¹	TO-92	150	K/W
			SOT-89	90	
			SOT-223	60	

Note 1: 60 Hz AC resistive load condition, 100% conduction

Characteristic Curves

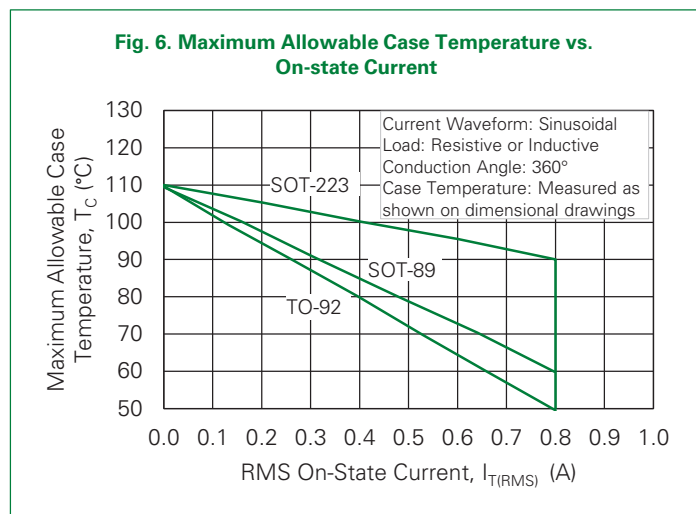
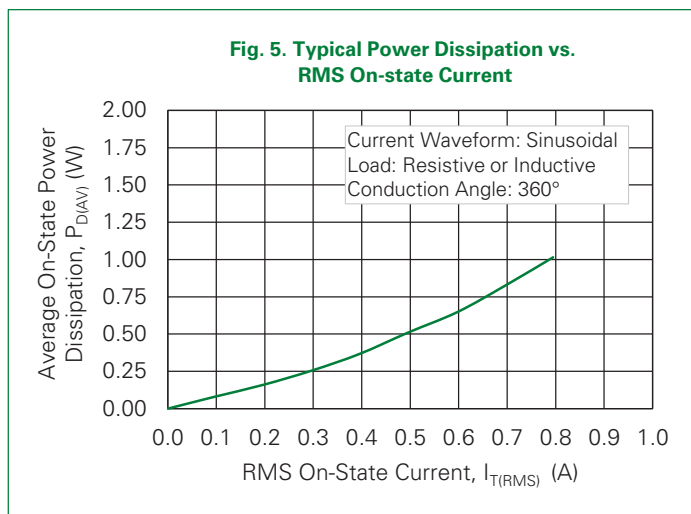
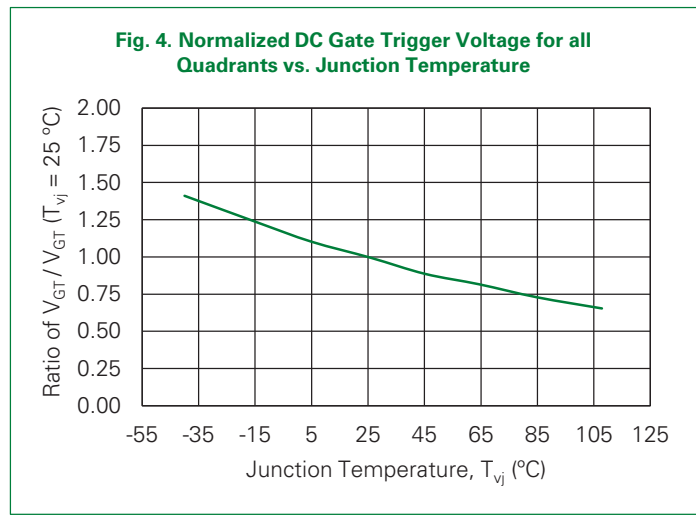
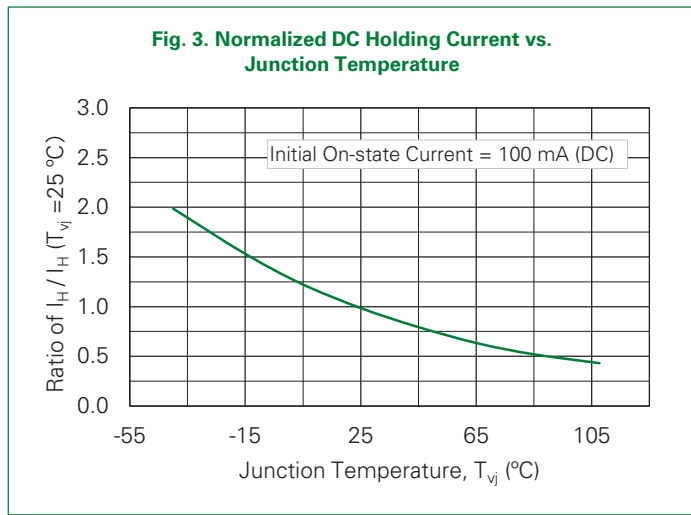
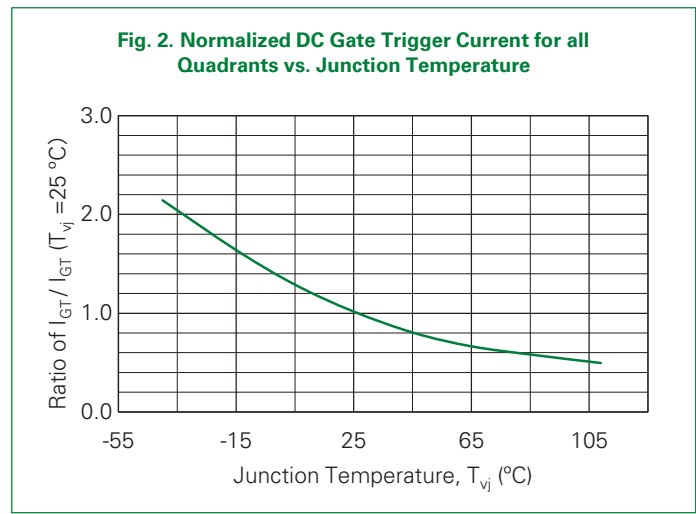
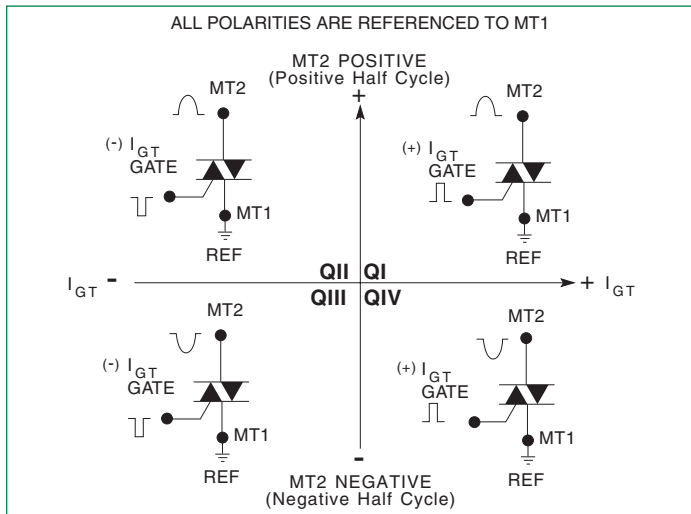
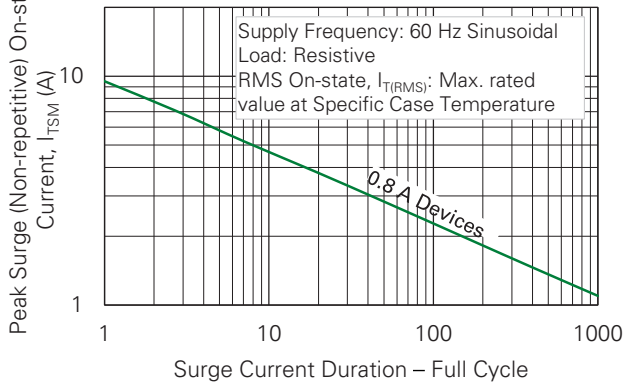

Fig. 7. Surge Peak On-state Current vs. Number of Cycles



Notes:

1. Gate control may be lost during and immediately following surge current interval.
2. Overload may not be repeated until junction temperature has returned to steady-state rated value.

Soldering Parameters

Characteristic		Value
Reflow Condition		Pb – Free assembly
Pre-heat	Temperature Min ($T_{s(min)}$)	150°C
	Temperature Max ($T_{s(max)}$)	200°C
	Time (min to max) (t_s)	60 – 180 secs
Average ramp up rate (Liquidus Temp)(T_L) to peak		5°C/second max
$T_{s(max)}$ to T_L - Ramp-up Rate		5°C/second max
Reflow	Temperature (T_L) (Liquidus)	217°C
	Time (t_L)	60 – 150 seconds
Peak Temperature (T_p)		260 ^{+0/-5} °C
Time within 5°C of actual peak Temperature (t_p)		20 – 40 seconds
Ramp-down Rate		5°C/second max
Time 25°C to peak Temperature (T_p)		8 minutes max
Do Not Exceed		280°C

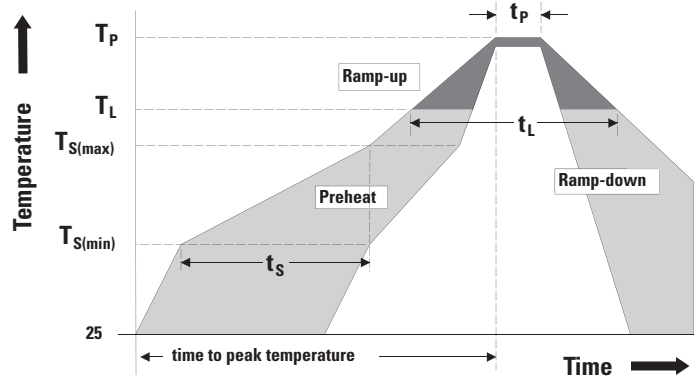

Environmental Specifications

Test	Specifications and Conditions
AC Blocking	MIL-STD-750, M-1040, Cond A Applied Peak AC voltage @ 110 °C for 1008 hours
Temperature/Humidity	EIA / JEDEC, JESD22-A101, 1008 hours; 320 V - DC: 85 °C; 85 % relative humidity
Temperature Cycling	MIL-STD-750, M-1051, 100 cycles; -40 °C to +150 °C; 15-min dwell-time
High-temperature Storage	MIL-STD-750, M-1031, 1008 hours; 150 °C
Low-temperature Storage	1008 hours; -40 °C
Resistance to Solder Heat	MIL-STD-750: Method 2031
Solderability	ANSI/J-STD-002: category 3, Test A
Lead Bend	MIL-STD-750, M-2036 Cond E

Physical Specifications

Characteristic	Value
Terminal Finish	100% Matte Tin-plated
Body Material	UL Recognized compound meeting flammability rating V-0
Lead Material	Copper Alloy

Design Considerations

Careful selection of the correct component for the application's operating parameters and environment will go a long way toward extending the operating life of the Thyristor. Good design practice should limit the maximum continuous current through the main terminals to 75% of the component rating. Other ways to ensure long life for a power discrete semiconductor are proper heat sinking and selection of voltage ratings for worst case conditions. Overheating, overvoltage (including dv/dt), and surge currents are the main killers of semiconductors. Correct mounting, soldering, and forming of the leads also help protect against component damage.

Product Selector

Part Number	Voltage		Gate Sensitivity Quadrants		Package
	400 V	600 V	I – II – III	IV	
LX803DE	X	–	3 mA	5 mA	TO-92
LX803ME	–	X	3 mA	5 mA	TO-92
LX803DT	X	–	3 mA	5 mA	SOT-223
LX803MT	–	X	3 mA	5 mA	SOT-223
LX807DE	X	–	5 mA	7 mA	TO-92
LX807ME	–	X	5 mA	7 mA	TO-92
LX807DT	X	–	5 mA	7 mA	SOT-223
LX807MT	–	X	5 mA	7 mA	SOT-223
LX807MB	–	X	5 mA	7 mA	SOT-89

Packing Options

Part Number	Marking	Weight	Packing Mode	Base Quantity
LX8xyE	LX8xyE	0.217 g	Bulk	2500
LX8xyEAP	LX8xyE	0.217 g	Ammo Pack	2000
LX8xyERP	LX8xyE	0.217 g	Tape & Reel	2000
LX8xyTRP	LX8xyT	0.120 g	Tape & Reel	1000
LX8xyBRP	8xx	0.053 g	Tape & Reel	1000

Note: xx = gate sensitivity, y = voltage

Part Numbering and Marking

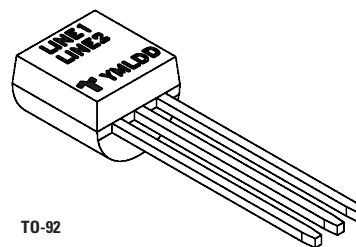
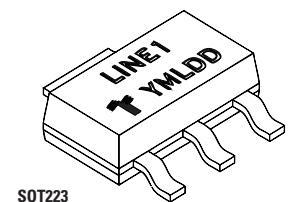
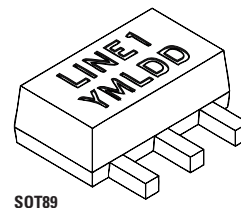
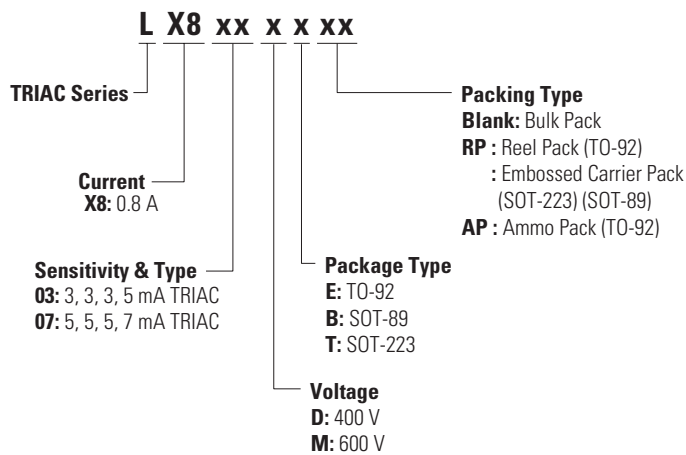

Line1 = Littelfuse Part Number
 Line2 = continuation...Littelfuse Part Number
 Y = Last Digit of Calendar Year
 M = Letter Month Code (A-L for Jan-Dec)
 L = Location Code
 DD = Calendar Date

Package Dimensions TO-92

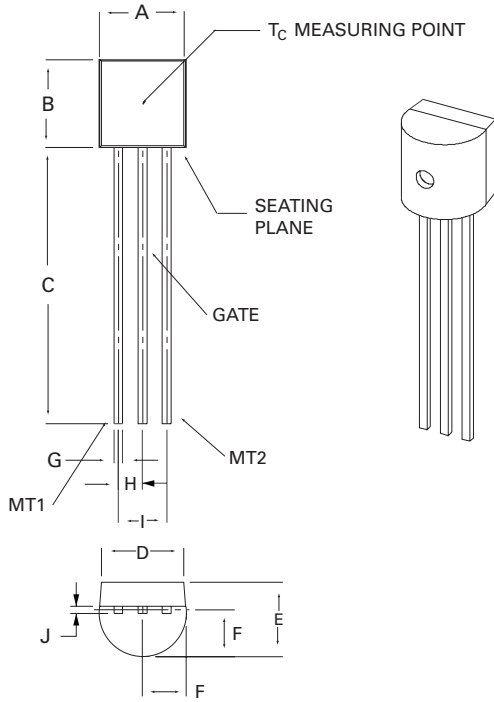

Symbol	Millimeters		Inches	
	Min.	Max.	Min.	Max
A	4.450	5.200	0.175	0.205
B	4.320	5.330	0.170	0.210
C	12.70	–	0.500	–
D	3.430	–	0.135	–
E	3.180	4.190	0.125	0.165
F	2.040	2.660	0.080	0.105
G	0.407	0.533	0.016	0.021
H	1.150	1.390	0.045	0.055
I	2.420	2.660	0.095	0.105
J	0.380	0.500	0.015	0.020

Package Dimensions SOT-223

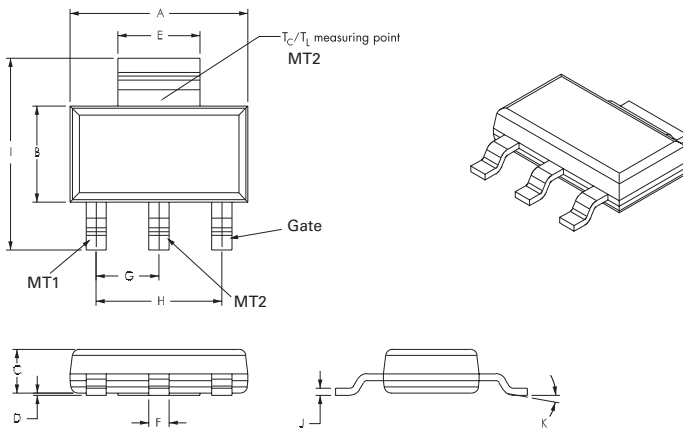

Symbol	Millimeters			Inches		
	Min.	Typ.	Max.	Min.	Typ.	Max.
A	6.30	6.50	6.70	0.248	0.256	0.264
B	3.30	3.50	3.70	0.130	0.138	0.146
C	–	–	1.80	–	–	0.071
D	0.02	–	0.10	0.001	–	0.004
E	2.90	3.00	3.15	0.114	0.118	0.124
F	0.60	0.70	0.85	0.024	0.027	0.034
G	–	2.30	–	–	0.090	–
H	–	4.60	–	–	0.181	–
I	6.70	7.00	7.30	0.264	0.276	0.287
J	0.24	0.26	0.35	0.009	0.010	0.014
K	10° MAX.					

Pad Layout for SOT-223

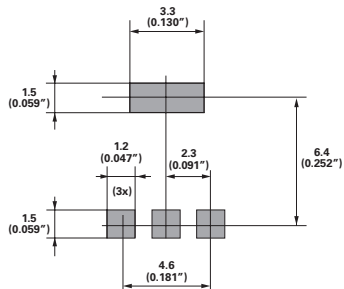

Dimensions in Millimeters (Inches)

Package Dimensions SOT-89

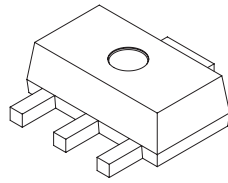
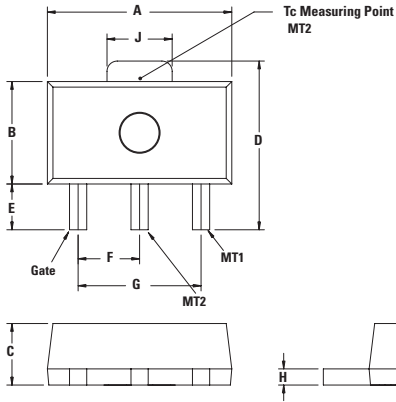

Symbol	Millimeters			Inches		
	Min.	Typ.	Max.	Min.	Typ.	Max.
A	4.40	–	4.60	0.173	–	0.181
B	2.29	–	2.60	0.090	–	0.102
C	1.40	–	1.60	0.055	–	0.063
D	3.94	–	4.25	0.155	–	0.167
E	0.81	–	1.20	0.032	–	0.047
F	–	1.5	–	–	0.059	–
G	–	3	–	–	0.118	–
H	0.35	–	0.44	0.014	–	0.017
I	0.36	–	0.48	0.014	–	0.019
J	–	1.65	–	–	0.065	–

Pad Layout for SOT-89

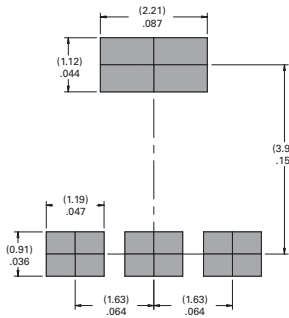

Dimensions in Millimeters (Inches)

TO-92 (3-lead) Reel Pack (RP) Radial Leaded Specifications

Meets all EIA-468-C Standards

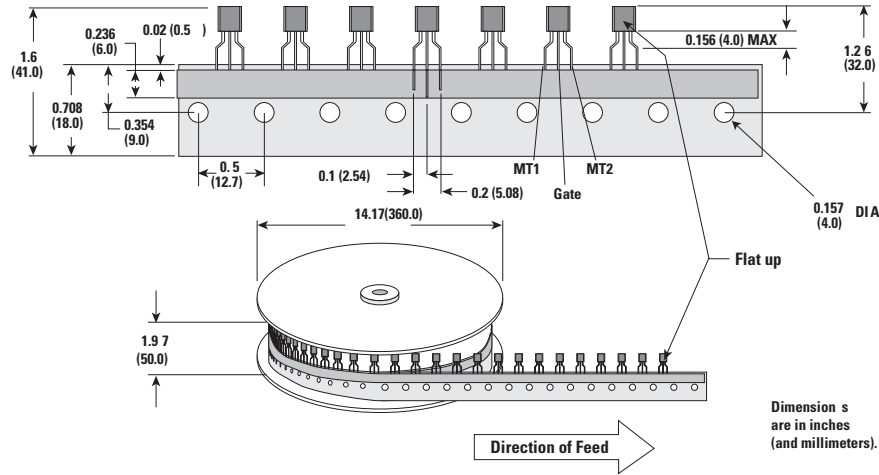

Dimensions are in inches (and millimeters).

TO-92 (3-lead) Ammo Pack (AP) Radial Leaded Specifications

Meets all EIA-468-C Standards

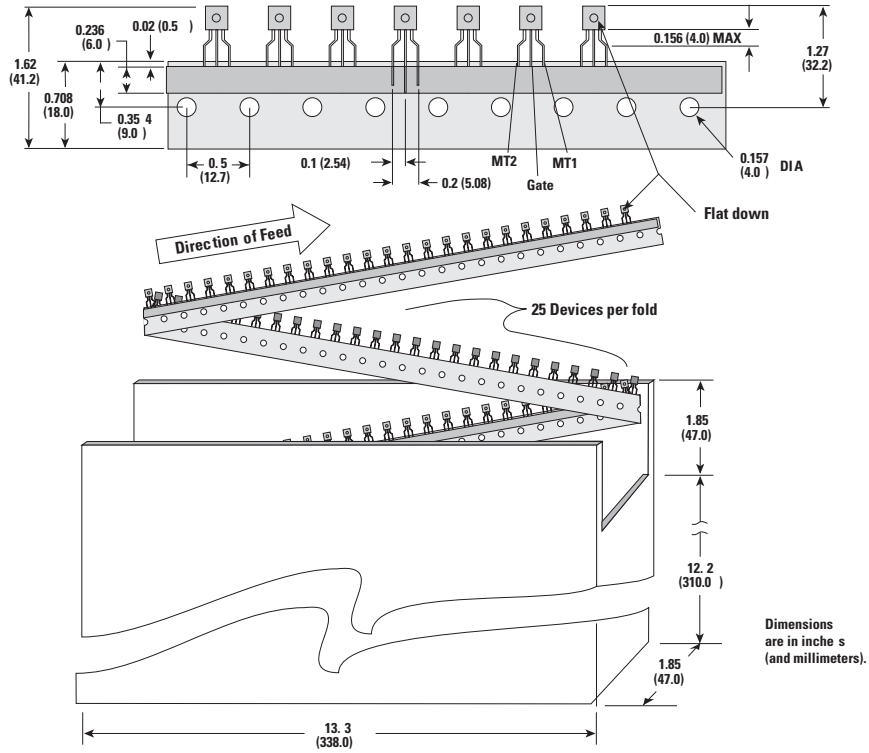

SOT-89 Reel Pack (RP) Specifications

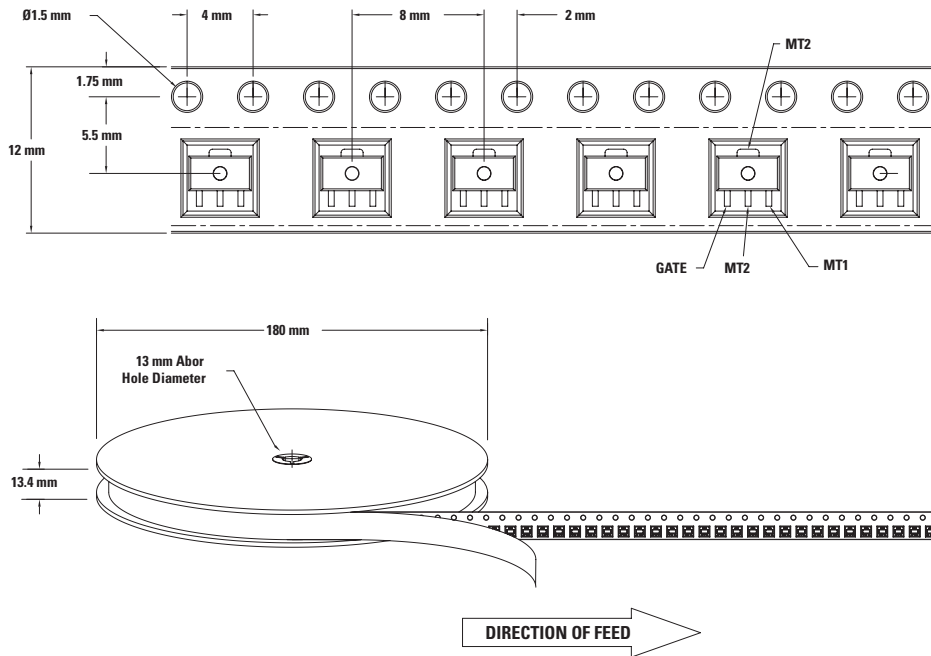

SOT-89 Reel Pack (RP1) Specifications

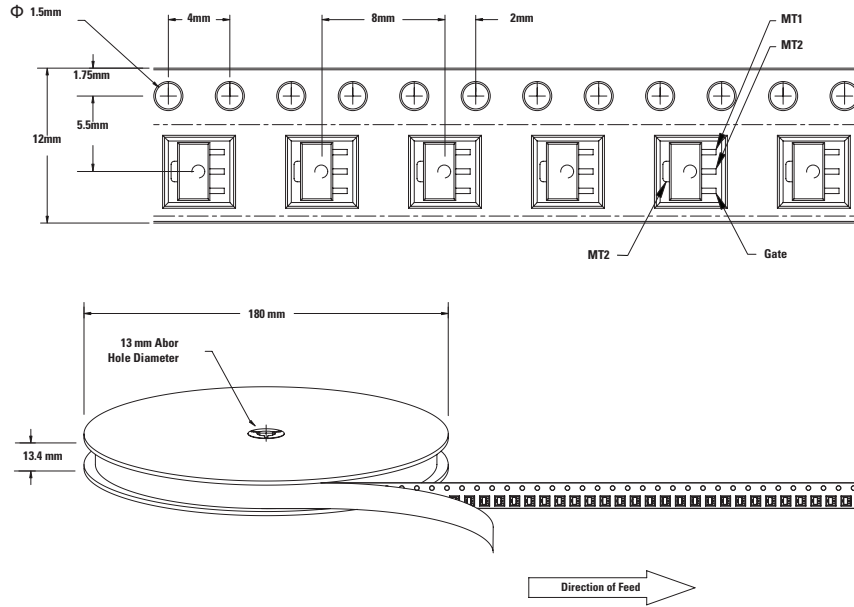

SOT-223 Reel Pack (RP) Specifications

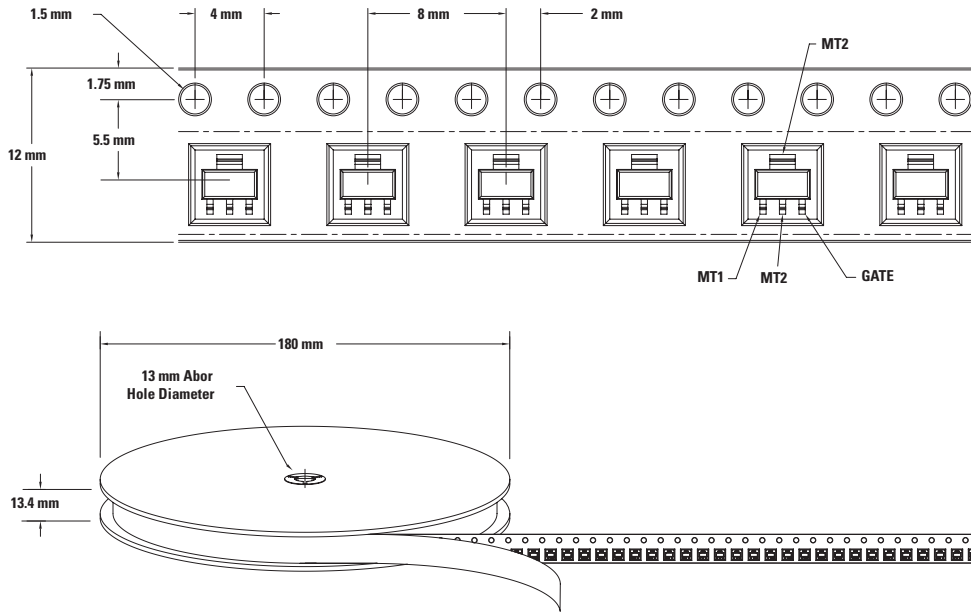

Disclaimer Notice

Information furnished is believed to be accurate and reliable. However, users should independently evaluate the suitability of and test each product selected for their own applications. Littelfuse products are not designed for, and may not be used in, all applications. Read complete Disclaimer Notice at <http://www.littelfuse.com/disclaimer-electronics>.



Part of:

