

**Specification Status: Released**

**Maximum Electrical Rating**

**Voltage: 6.0V<sub>DC</sub>**

**Short Circuit Current: 100A**

**Notes:**

1. All terminations are tin plated.
2. Drawing not to scale

**Marking:**

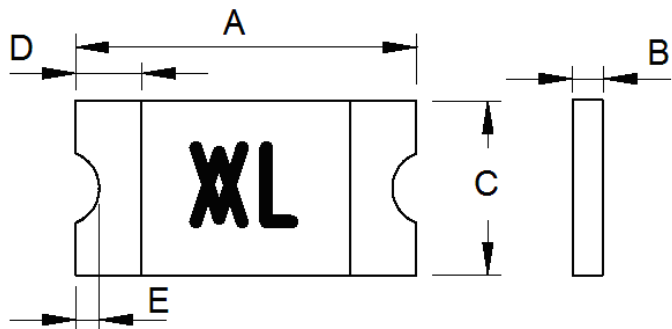
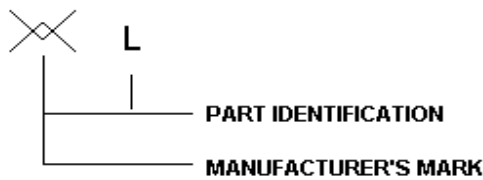

**TABLE I. DIMENSIONS:**

|     | A       |         | B       |         | C       |         | D       |         | E       |
|-----|---------|---------|---------|---------|---------|---------|---------|---------|---------|
|     | MIN     | MAX     | MIN     | MAX     | MIN     | MAX     | MIN     | MAX     | MIN     |
| mm: | 3.00    | 3.40    | 0.44    | 0.68    | 1.37    | 1.80    | 0.25    | 0.75    | 0.076   |
| in: | (0.118) | (0.134) | (0.017) | (0.027) | (0.054) | (0.071) | (0.010) | (0.030) | (0.003) |

**TABL II. PERFORMANCE RATINGS:**

| CURRENT RATINGS** |      |                 |      |                 |      | TIME TO TRIP**        | RESISTANCE VALUES |      | TRIPPED-STATE POWER DISSIPATION** |
|-------------------|------|-----------------|------|-----------------|------|-----------------------|-------------------|------|-----------------------------------|
| AMPERES AT 0°C    |      | AMPERES AT 25°C |      | AMPERES AT 60°C |      | SECONDS AT 25°C, 8.0A | OHMS AT 25°C      |      | WATTS AT 25°C, 6.0V               |
| HOLD              | TRIP | HOLD            | TRIP | HOLD            | TRIP | MAX                   | MIN               | MAX* | MAX                               |
| 0.92              | 1.87 | 0.75            | 1.50 | 0.58            | 1.14 | 0.1                   | 0.09              | 0.30 | 0.8                               |

\*Maximum resistance is measured 1 hour after reflow.

\*\* Values specified were determined using PCB's with 0.030"X1.5 ounce copper traces.

Agency Recognition: UL, CSA, TÜV  
 Reference Document: PS300  
 Precedence: This specification takes precedence over documents referenced herein.  
 Effectivity: Reference documents shall be the issue in effect on the date of invitation for bid.  
 CAUTION: Operation beyond the rated voltage or current may result in rupture, electrical arcing or flame.

**Materials Information**

**ROHS Compliant**

Directive 2002/95/EC  
Compliant

**ELV Compliant**

Directive 2000/53/EC  
Compliant

**Pb-Free**



**Halogen Free\***



\* Halogen Free refers to: Br≤900ppm, Cl≤900ppm, Br+Cl≤1500ppm.



**PolySwitch®**  
**PTC Devices**  
**Overcurrent Protection Device**

**PRODUCT: nanoSMDC075F**

DOCUMENT: SCD25128  
REV LETTER: N  
REV DATE: JULY 26, 2016  
PAGE NO.: 2 OF 2

Information furnished is believed to be accurate and reliable. However, users should independently evaluate the suitability of and test each product selected for their own applications. Littelfuse products are not designed for, and shall not be used for, any purpose (including, without limitation, military, aerospace, medical, lifesaving, life-sustaining or nuclear facility applications, devices intended for surgical implant into the body, or any other application in which the failure or lack of desired operation of the product may result in personal injury, death, or property damage) other than those expressly set forth in applicable Littelfuse product documentation. Warranties granted by Littelfuse shall be deemed void for products used for any purpose not expressly set forth in applicable Littelfuse documentation. Littelfuse shall not be liable for any claims or damages arising out of products used in applications not expressly intended by Littelfuse as set forth in applicable Littelfuse documentation. The sale and use of Littelfuse products is subject to Littelfuse Terms and Conditions of Sale, unless otherwise agreed by Littelfuse.