

EL731 MODBUS TCP INTERFACE

Revision 2-A-121614



Copyright © 2014 Littelfuse Startco

All rights reserved.

This page left intentionally blank.

TABLE OF CONTENTS

SECTION	PAGE
1 General	1
2 Installation	1
3 Modbus Configuration	1
3.1 Configuration Software.....	1
3.2 LED Indication.....	1
4 Modbus/TCP Protocol	2
4.1 Modbus/TCP Memory Addressing	2
4.1.1 Write Process	2
4.1.2 Read Process	2
4.2 Modbus TCP Communications	3
Appendix A EL731 Modbus TCP Interface	
Revision History	8

LIST OF FIGURES

FIGURE	PAGE
3.1 LED Indicators.....	1

LIST OF TABLES

TABLE	PAGE
3.1 NS - Network Status LED.....	1
3.2 MS - Module Status LED.....	1
3.3 LINK - LINK/Activity LED	1
4.1 Function Codes	2
4.2 Write Process	2
4.3 Read Process	2
4.4 Modbus TCP Communications Table.....	3
4.5 Register Formats	6

DISCLAIMER

Specifications are subject to change without notice. Littelfuse Startco is not liable for contingent or consequential damages, or for expenses sustained as a result of incorrect application, incorrect adjustment, or a malfunction.

This page intentionally left blank.

1. GENERAL

This document describes the AC700-CUA-04 Communications Upgrade Adapter Modbus TCP features supported by the EL731.

The adapter allows uploading custom web pages to access and display data.

2. INSTALLATION

Before installing the adapter, note its MAC ID.

To field-install an AC700-CUA Communications Upgrade Adapter, disconnect the EL731 supply voltage, remove the adapter-access cover, insert the adapter, and retain with the supplied screws. Apply the supply voltage.

3. MODBUS CONFIGURATION

3.1 CONFIGURATION SOFTWARE

With the communications module installed, a standard RJ45 network cable can be used to connect the EL731 to a Modbus TCP network. If connecting directly to a computer, the use of a router is recommended. Set the IP address using the IP Config software available at www.littelfuse.com/protectionrelays. The software requires Microsoft Windows operating system. The Modbus interface supports 10/100-Mbit, full- or half-duplex operation.

All module addresses for connected Anybus modules will be displayed. The MAC address displayed on the adapter is used to identify a specific EL731.

3.2 LED INDICATION

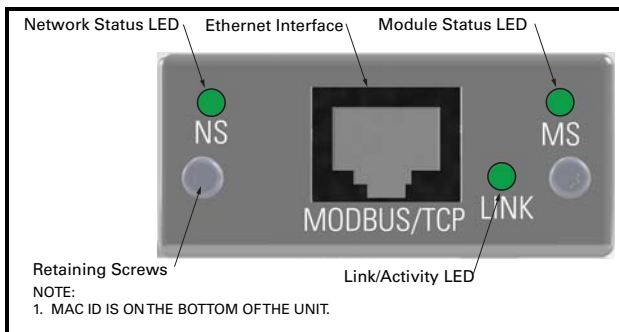

FIGURE 3.1 LED Indicators.

TABLE 3.1 NS - NETWORK STATUS LED

STATE	DESCRIPTION
Steady Off	No Power or No IP address
Steady Green	Module Is In Process Active Or Idle State
Flashing Green	Waiting For Connections
Flashing Red	Process Active Timeout
Steady Red	Duplicate IP Address, or FATAL Event

NOTE: A test sequence is performed on this LED during startup.

TABLE 3.2 MS - MODULE STATUS LED

STATE	DESCRIPTION
Steady Off	No Power
Steady Green	Normal Operation
Flashing Red	Minor Fault In Diagnostic Object; IP Conflict
Steady Red	Major Fault; Module Is In State EXCEPTION (Or FATAL Event)

NOTE: A test sequence is performed on this LED during startup.

TABLE 3.3 LINK - LINK/ACTIVITY LED

STATE	DESCRIPTION
Steady Off	No Link, No Activity
Steady Green	Link Established
Flickering Green	Activity

4. MODBUS/TCP PROTOCOL

The EL731 Modbus TCP module can handle up to 8 simultaneous connections. It supports all of the Modbus/TCP class 0 and class 1 and some of the class 2 commands.

Word addressing (4xxxx) is supported. A 16-bit word can be read as a single word using word addressing. The use of the Modbus prefix 0, 1, 3, and 4 is a function of the master and may not be required. Check the master's documentation.

Table 4.1 Function Codes

FUNCTION CODE	FUNCTION NAME	CLASS	AFFECTS AREA	ADDRESSING METHOD	MODBUS GROUP
1	Read Coils	1	IN/OUT	Bit	0xxxx
2	Read Input Discretes	1	IN/OUT	Bit	1xxxx
3	Read Multiple Registers	0	IN/OUT	Word	4xxxx
4	Read Input Registers	1	IN/OUT	Word	3xxxx
5	Write Coil	1	OUT	Bit	0xxxx
6	Write Single Register	1	OUT	Word	4xxxx
7 *	Read Exception Status	1	-	-	-
15	Force Multiple Coil	2	OUT	Bit	0xxxx
16	Force Multiple Registers	0	OUT	Word	4xxxx
22	Mask Write Register	2	OUT	Word	-
23	Read/Write Registers	2	IN/OUT	Word	-

- * Exception Code 01: Illegal Function
- Exception Code 02: Illegal Data Address
- Exception Code 03: Illegal Data Value

4.1 MODBUS/TCP MEMORY ADDRESSING

4.1.1 WRITE PROCESS

The Write Process area contains data that can be read using Function Codes 1, 2, 3, 4, and 23. It is not possible to write to the Write Process area. The data is available in 16-bit format and starts at memory address 256.

Table 4.2 Write Process

MEMORY ADDRESS (Modbus Address)	ATTRIBUTE	TYPE
256	Trip State	UINT16
257		
258	Alarm State	UINT16
259		

4.1.2 READ PROCESS

The read process area is used to enable/disable CT1 and CT2. Address 1 and 3 are the Command Registers. A transition from 0 to 3 tells the EL731 to write the value at Address 0 and 2 to the EL731. To enable CT1, set register 0 to 1, and then change the Command Register at 1 from 0 to 3.

Table 4.3 Read Process

MEMORY ADDRESS (Modbus Address)	ATTRIBUTE	TYPE
0	CT1 Enable	UINT16
1	Command Register	
2	CT2 Enable	UINT16
3	Command Register	

4.2 MODBUS TCP COMMUNICATIONS

Table 4.4 Modbus TCP Communications Table

MEMORY ADDRESS (Modbus Address)	ATTRIBUTE	ACCESS	TYPE
528	Model Code	Read	T1
529			
530	Firmware Version	Read	T1
531			
532	Serial Number	Read	T2 (Low)
533		Read	T2 (High)
534	Model Option	Read	T2 (Low)
535		Read	T2 (High)
536	Reserved		
537			
538	CT1 Enable	Read/Write	T3
539			
540	CT1 Primary Turns	Read/Write	T1
541			
542	CT1 Trip Time	Read/Write	T2 (Low)
543		Read/Write	T2 (High)
544	CT1 Trip Level	Read/Write	T2 (Low)
545		Read/Write	T2 (High)
546	Reserved		
547			
548	CT1 Alarm Level	Read/Write	T2 (Low)
549		Read/Write	T2 (High)
550	CT1 Calibrate	Write	T4
551			
552	Reserved		
553			
554	Reserved		
555			
556	CT2 Enable	Read/Write	T3
557			
558	CT2 Primary Turns	Read/Write	T1
559			
560	CT2 Trip Time	Read/Write	T2 (Low)
561		Read/Write	T2 (High)
562	CT2 Trip Level	Read/Write	T2 (Low)
563		Read/Write	T2 (High)
564	Reserved		
565			
566	CT2 Alarm Level	Read/Write	T2 (Low)
567		Read/Write	T2 (High)
568	CT2 Input Filter	Read/Write	T5
569			
570	Reserved		
571			
572	Reserved		
573			
574	Reserved		

Table 4.4 Modbus TCP Communications Table (continued)

MEMORY ADDRESS (Modbus Address)	ATTRIBUTE	ACCESS	TYPE
575			
576	Reserved		
577			
578	PTC Trip Action	Read/Write	T3
579			
580	PTC Alarm Action	Read/Write	T3
581			
582	Reserved		
583			
584	Reserved		
585			
586	RTD Trip Action	Read/Write	T3
587			
588	RTD Trip Level	Read/Write	T2 (Low)
589		Read/Write	T2 (High)
590	RTD Alarm Action	Read/Write	T3
591			
592	RTD Alarm Level	Read/Write	T2 (Low)
593		Read/Write	T2 (High)
594	Reserved		
595			
596	Reserved		
597			
598	Relay 1 Function	Read/Write	T6
599			
600	Relay 1 Mode	Read/Write	T7
601			
602	Relay 2 Function	Read/Write	T6
603			
604	Relay 2 Mode	Read/Write	T7
605			
606	Relay 3 Function	Read/Write	T6
607			
608	Relay 3 Mode	Read/Write	T7
609			
610	Reserved		
611			
612	Reserved		
613			
614	Analog Out CT Select	Read/Write	T8
615			
616	Analog % Level	Read/Write	T9
617			
618	Output Filter	Read/Write	T3
619			
620	Reserved		
621			
622	Reserved		
623			
624	Temp. Sensor	Read/Write	T10

Table 4.4 Modbus TCP Communications Table (continued)

MEMORY ADDRESS (Modbus Address)	ATTRIBUTE	ACCESS	TYPE
625			
626	Reserved		
627			
628	Reserved		
629			
630	Display Filter	Read/Write	T3
631			
632	Reserved		
633			
634	Reserved		
635			
636	CT1 Current	Read	T11 (Low)
637		Read	T11 (High)
638	CT2 Current	Read	T11 (Low)
639		Read	T11 (High)
640	Full Current	Read	T11 (Low)
641		Read	T11 (High)
642	Internal Temp.	Read	T11 (Low)
643		Read	T11 (High)
644	PTC Temp.	Read	T11 (Low)
645		Read	T11 (High)
646	RTD Temperature	Read	T11 (Low)
647		Read	T11 (High)
648	Reserved		
649			
650	Reserved		
651			
652	Clear Counters	Write	T4
653			
654	Load Defaults	Write	T4
655			
656	Restart System	Write	T4
657			
658	Reserved		
659			
660	Reserved		
661			
662	Trip State	Read	T12
663			
664	Alarm State	Read	T13
665			
666	Trip Counter	Read	T1
667			
668	Alarm Counter	Read	T1
669			
670	System Uptime	Read	T2 (Low)
671		Read	T2 (High)
672	Reserved		
673			
674	Reserved		
675			

Table 4.4 Modbus TCP Communications Table (continued)

MEMORY ADDRESS (Modbus Address)	ATTRIBUTE	ACCESS	TYPE
676	Running Time (s)	Read	T2 (Low)
677		Read	T2(High)
678	External Reset	Write	T4
679			

Table 4.5 Register Formats

TYPE	DESCRIPTION.
T1	16-Bit Integer
T2	32-Bit Unsigned Integer
T3	0 = Disable 1 = Enable
T4	Command 1 = Send Command
T5	CT2 Input Filter 0 = None 1 = Full Range 2 = 90 Hz Low Pass 3 = 190 Hz High Pass 4 = 3 kHz Low Pass
T6	Relay Functions 0 = Trip 1 = Alarm 2 = Watchdog 3 = Current
T7	Relay Mode 0 = Non-Fail-Safe 1 = Fail-Safe
T8	Analog Out CT Select 0 = CT1 1 = CT2 2 = Both CT's
T9	Analog % Level 0 = 0 – 5A Normal Mode 1 = 0 – Trip Level (% Trip Level Mode)
T10	Temp. Sensor 0 = Disabled 1 = RTD Sensor 2 = PTC Sensor
T11	32-Bit Signed Integer, (High) Bits 31..16, (Low) Bits 15..0
T12	Trip Status Bit0: 1 = System Running Bit1: 1 = Trip Current CT1 Bit2: 1 = Trip Current CT2 Bit3: 1 = Trip User Test Bit4: 1 = Trip CT1 Detect Bit5: 1 = Trip CT2 Detect Bit6: 1 = Trip NVRAM Error Bit7: 1 = Calibrate Bit8: 1 = Calibrate Init, Bit9: 1 = Trip Calibrate Bit10: 1 = Trip PTC Sensor Bit11: 1 = Trip RTD Sensor Bit12: 1 = System Disabled

Table 4.5 Register Formats (continued)

TYPE	DESCRIPTION
T13	Alarm Status Bit0: 1 = No Alarms Bit1: 1 = CT1 Current Bit2: 1 = CT2 Current Bit3: 1 = PTC Sensor Bit4: 1 = RTD Sensor Bit5: 1 = System Disabled
T14	Command Register: Sends command when charged from 0 to 3.

APPENDIX A
EL731 MODBUS TCP INTERFACE REVISION HISTORY

MANUAL RELEASE DATE	MANUAL REVISION
December 16, 2014	2-A-121614

MANUAL REVISION HISTORY

REVISION 2-A-121614

SECTION 4

Table 4.5, T13 (Bit0) updated.

APPENDIX A

Revision history added.