

Braking Rectifier Assemblies

| Typ | Typical | | | Max. | | | |
|---------------|-----------------|----------------|-----------------|-----------------|----------------|----------------|----------------------------|
| | V_{vRMS} V | V_{dAV} V | I_{dAVM} A | I_{dAVM} A | V_{RRM} V | I_{FSM} A | I^2t A ² s |
| VGB 0124 AY7a | 380 | 340 | 1.0 | 1.0 | 1400 | 60 | 28 |

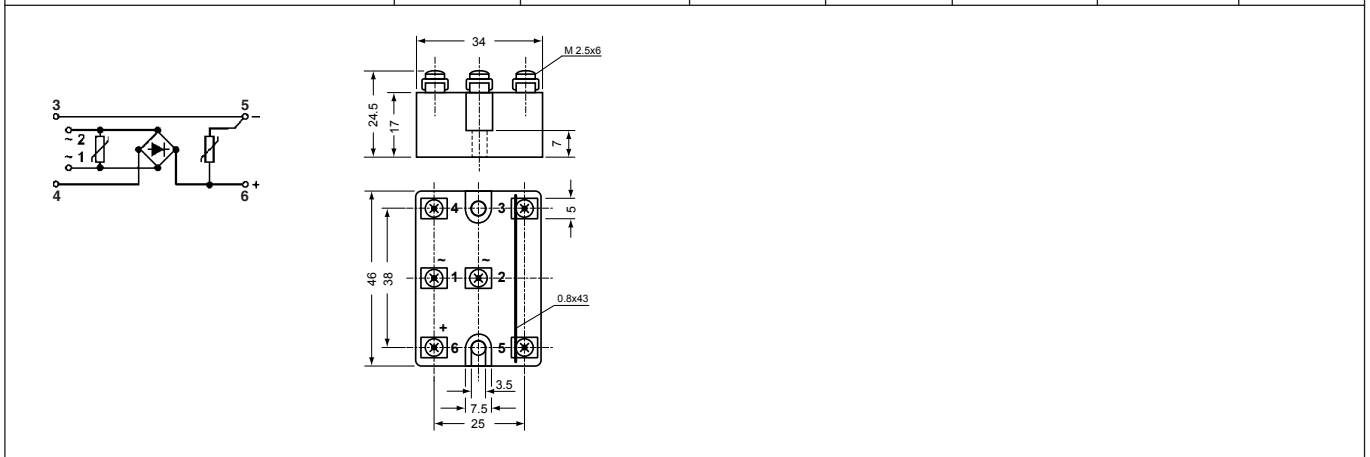

| Typ | Typical | | | Max. | | | |
|-------------|-----------------|----------------|-----------------|-----------------|----------------|----------------|----------------------------|
| | V_{vRMS} V | V_{dAV} V | I_{dAVM} A | I_{dAVM} A | V_{RRM} V | I_{FSM} A | I^2t A ² s |
| VGf 0136 AB | 1000 | 440 | 1.2 | 1.5 | 2800 | 80 | 40 |

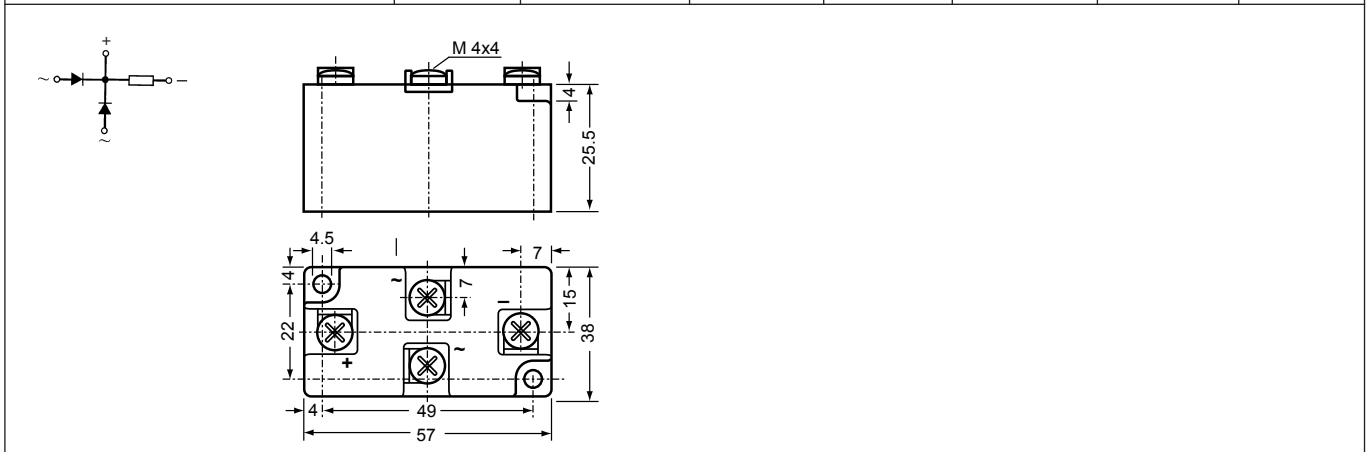

Data according to IEC 60747

Disclaimer Notice

Information furnished is believed to be accurate and reliable. However, users should independently evaluate the suitability of and test each product selected for their own applications. Littelfuse products are not designed for, and may not be used in, all applications. Read complete Disclaimer Notice Disclaimer Notice at www.littelfuse.com/disclaimer-electronics.

IXYS reserves the right to change limits, test conditions and dimensions