

DST2060DJF

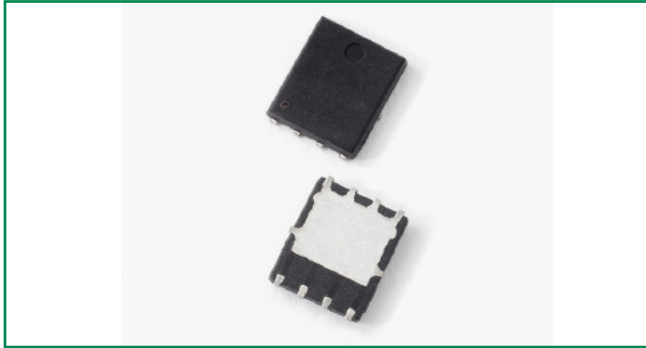

Schematic

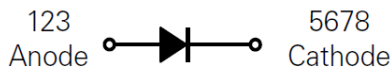

Pin out

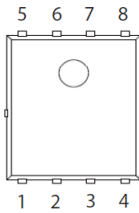

Pin	Function
1, 2, 3	Anode
4	Open
5, 6, 7, 8	Cathode

Description

Littelfuse DST series Ultra Low V_F Schottky Barrier Rectifier is designed to meet the general requirements of commercial and industry applications by providing high temperature, low leakage and lower V_F products.

It is suitable for high frequency switching mode power supply, free-wheeling diodes and polarity protection diodes.

Features

- Ultra low forward voltage drop
- High frequency operation
- High junction temperature capability
- Guard ring for enhanced ruggedness and long term reliability
- Single die in PDFNWB5x6-8L package

Applications

- Switching mode power supply
- DC/DC converters
- Free-Wheeling diodes
- Polarity Protection Diodes

Maximum Ratings

Parameters	Symbol	Test Conditions	Max	Unit
Peak Inverse Voltage	V_{RWM}	-	60	V
Average Forward Current (per device)	$I_{F(AV)}$	50% duty cycle @ $T_C = 80^\circ\text{C}$ rectangular wave form	20	A
Peak One Cycle Non-Repetitive Surge Current (per diode)	I_{FSM}	8.3 ms, half Sine pulse	150	A

Electrical Characteristics

Parameters	Symbol	Test Conditions	Max	Unit
Forward Voltage Drop (per diode)*	V_{F1}	@20A, Pulse, $T_J = 25^\circ\text{C}$	0.75	V
	V_{F2}	@20A, Pulse, $T_J = 125^\circ\text{C}$	0.70	
Reverse Current (per diode)*	I_{R1}	@ $V_R = \text{rated } V_R, T_J = 25^\circ\text{C}$	1	mA
	I_{R2}	@ $V_R = \text{rated } V_R, T_J = 125^\circ\text{C}$	40	

* Pulse Width < 300 μs , Duty Cycle < 2%

Thermal-Mechanical Specifications

Parameters	Symbol	Test Conditions	Max	Unit
Junction Temperature	T_J		-55 to +150	$^\circ\text{C}$
Storage Temperature	T_{stg}		-55 to +150	$^\circ\text{C}$
Typical Thermal Resistance Junction to Case (per diode)	R_{thJC}	DC operation	2.6	$^\circ\text{C/W}$
Approximate Weight	wt		0.095	g
Case Style		PDFNWB5x6-8L		

Figure 1: Typical Forward Characteristics

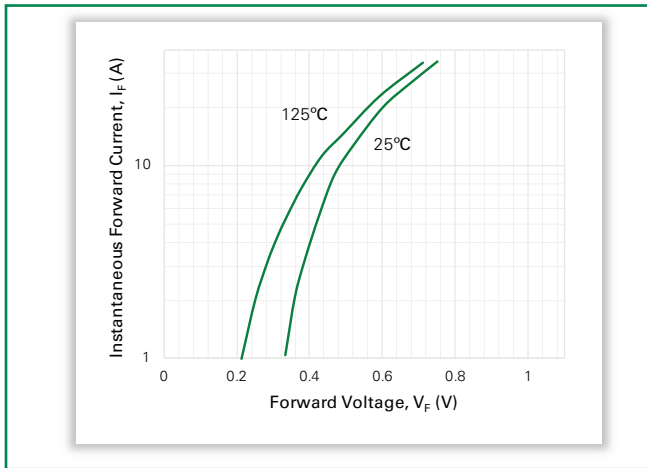

Figure 2: Typical Reverse Characteristics

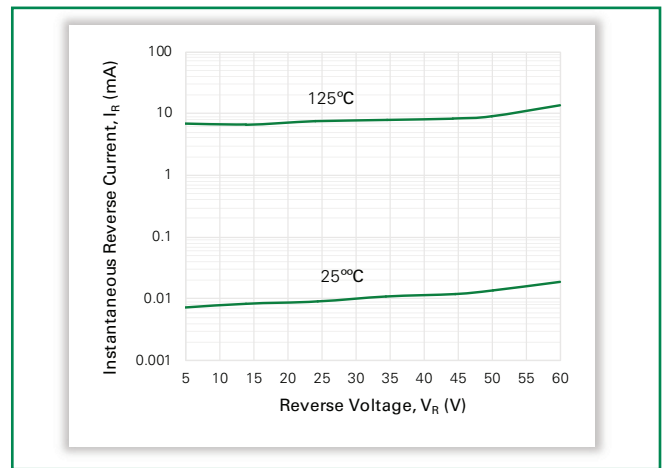
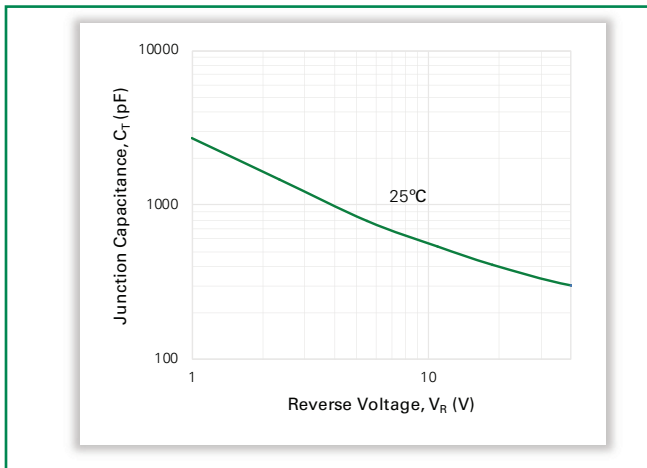
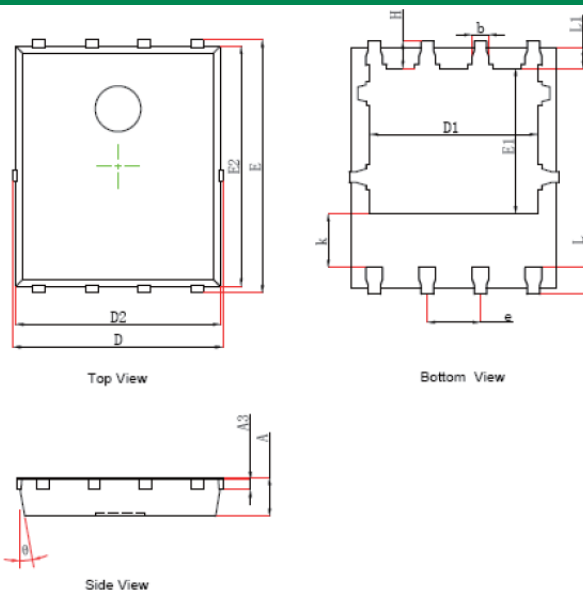

Figure 3: Typical Junction Capacitance



Dimensions-PDFNWB5x6-8L



Symbol	Millimeters	
	Min	Max
A	0.900	1.000
A3	0.254 REF	
D	4.944	5.096
E	5.974	6.126
D1	3.910	4.110
E1	3.375	3.575
D2	4.824	4.976
E2	5.674	5.826
k	1.190	1.390
b	0.350	0.450
e	1.27 TYP	
L	0.559	0.711
L1	0.424	0.576
H	0.574	0.726
θ	10°	12°

Soldering Footprint

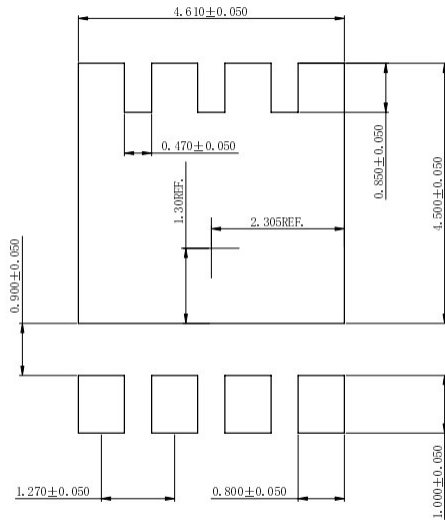

Dimensions: Millimeters

Part Numbering and Marking System

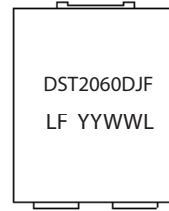

- DST = Device Type
- 20 = Forward Current (20A)
- 60 = Reverse Voltage (60V)
- DJF = Package Type
- LF = Littelfuse
- YY = Year
- WW = Week
- L = Lot Number

Packing Options

Part Number	Marking	Packing Mode	M.O.Q
DST2060DJF	DST2060DJF	3000pcs / Reel	3000

Carrier Tape & Reel Specification

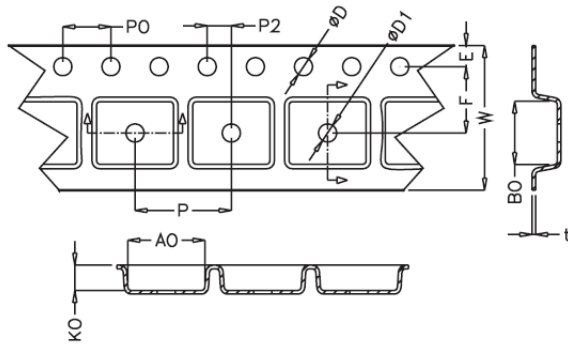

Symbol	Millimeters	
	Min	Max
A0	6.20	6.40
B0	5.20	5.40
D	1.50	1.60
D1	1.5	1.75
E	1.65	1.85
F	5.45	5.55
K0	1.00	1.20
P	7.90	8.10
P0	3.90	4.10
P2	1.95	2.05
W	11.90	12.30
t	0.23	0.27