

An application note for an IGBT failure check process

Precautions

Due to the structure of the IGBT die, a press-pack IGBT is both pressure and electrostatic discharge (ESD) sensitive. Non-homogeneous clamping or over clamping pressure on a device can potentially result in direct damage of the silicon or deterioration of the operating capability of the device.

Secondly, due to the MOSFET gate structure, an IGBT is sensitive to ESD. Personnel handling the device without taking appropriate ESD precautions may cause catastrophic damage to the device, due to the uncontrolled static discharge/ induced high voltages.

Failure sources and category

There are many causes of a press pack IGBT failure beyond the scope of this document, however some of the common failure mechanisms are described below:

1. Gate/Emitter short circuit (low impedance) - This type of failure is typically caused by the failure of the gate trigger circuit or due to loss of external control. Failure due to electrostatic damage or non-homogeneous or over clamping is also a possible cause of failure.
2. Collector/ Emitter short circuit - This type of failure is typically caused by an IGBT forward overvoltage failure or anti-parallel diode reverse overvoltage or due to loss of gate control. Failure due to non-homogeneous clamping or over clamping is also a possible cause of failure.
3. Three terminal short circuit - This type of failure is normally caused by dynamic switching failure when the device operates outside of the SOA limit or a consequential failure due to loss or interruption of the gate trigger.
4. Degraded blocking capability and/or high gate leakage - This is likely to have resulted from excessive junction temperature or from operation beyond the reverse bias operating area (RBSOA) limits or exceeding the voltage ratings.

With any of the symptoms above, the device should not be re-used.

Gate check

It is simple to use a curve tracer to quickly check the gate / emitter characteristic. Taking the Tektronix 576 type curve tracer as an example, the test procedure is given in the following process:

1. The IGBT must be uniformly clamped across the whole electrode surface and the clamp force must be within the datasheet limits.
2. Connect the emitter and the gate pin of IGBT to **C** and **E** plugs in the probe terminals of the curve tracer as shown in figure 1 and 2.
3. Set **Polarity** dial to **AC**
4. Switch **Left-Off-Right** to left or right according to the side of probe leads connected
5. Set **Max Peak Volts** to 15V
6. Set **Vertical Sensitivity** to 500 μ A/div
7. Set **Horizontal Sensitivity** to 5V/div
8. Turn **Variable Collector Supply** dial to maximum
9. Check the gate waveform on the screen. If the gate is within specification, a waveform with a threshold current spike will appear. If the gate is a short circuit, only a straight line along the vertical axis will be seen. Figure 3 shows a typical example of a gate waveform:

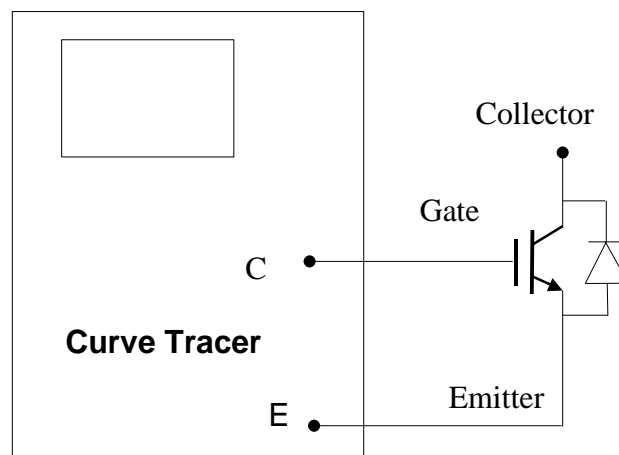

Figure 1: Schematic of the gate test

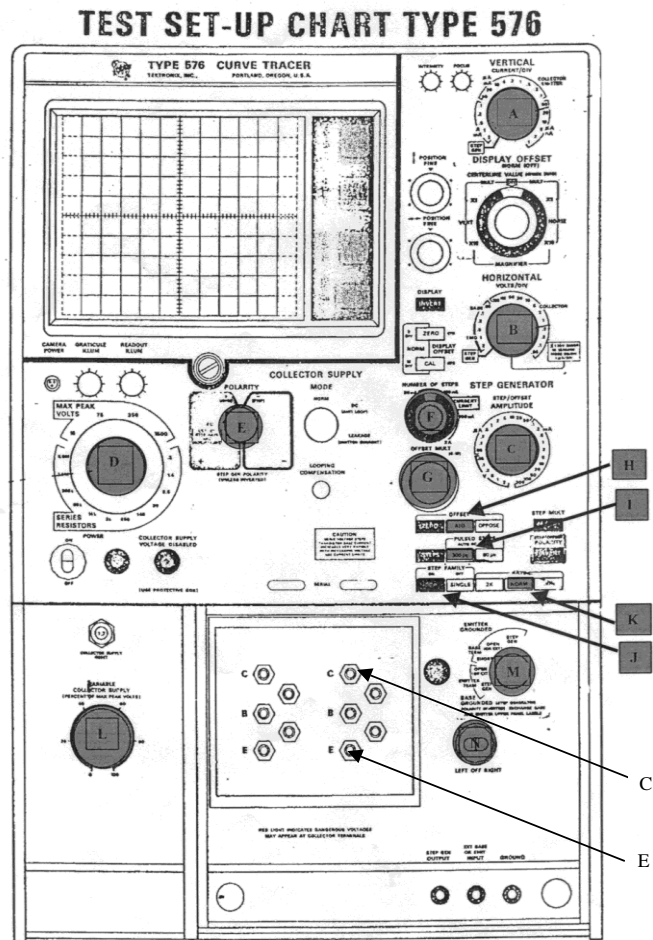

Figure 2: Front panel of the curve tracer

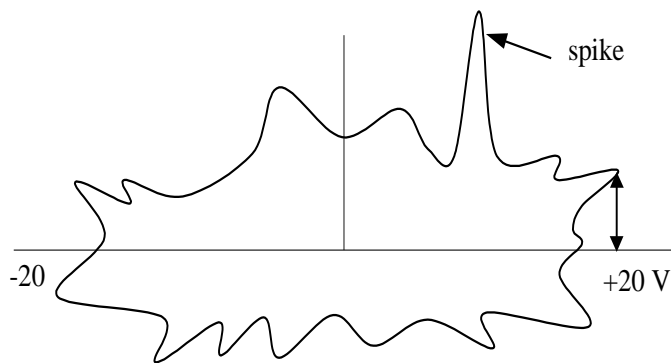

Figure 3: Gate current waveform

Forward voltage blocking check

Normally, a press-pack IGBT is unable to block the forward voltage once it has failed during dynamic switching. The blocking failure can be checked using a curve tracer. It must be noted however that the peak voltage of the curve tracer is limited to approximately 1800V so the full blocking capability of an IGBT cannot be tested with this equipment.

The procedure is given in the following process:

Note that this test involves potentially lethal voltages and should only be carried out by suitable qualified personnel.

1. Make sure the emitter to collector pin is short circuit.
2. The IGBT must be uniformly clamped across the whole electrode surface and the clamp force must be within the datasheet limits.
3. Connect the emitter and the collector pin of IGBT to **C** and **E** plugs in the probe terminals of the curve tracer as shown in figure 4.
4. Set **Polarity** dial to **NPN**
5. Switch **Left-Off-Right** to left or right according to the side of probe leads connected
6. Set **Max Peak Volts** to 1500V
7. Set **Horizontal Sensitivity** to 200V/div
8. Set **Vertical Sensitivity** to 2mA/div
9. Press safety interlock button to switch on the high voltage output (red light is indicating)
10. Slowly turn the **Variable Collector Supply** dial to increase the blocking voltage. If the device still blocks voltage, the leakage current waveform should be less than 20mA as shown in figure 5, otherwise the device is likely to fail blocking.

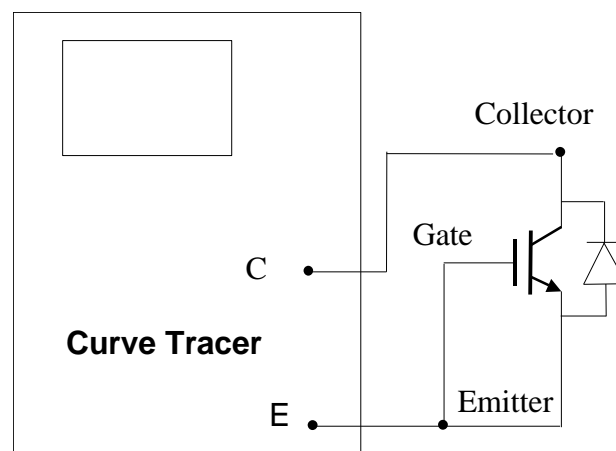

Figure 4: Schematic of the blocking test

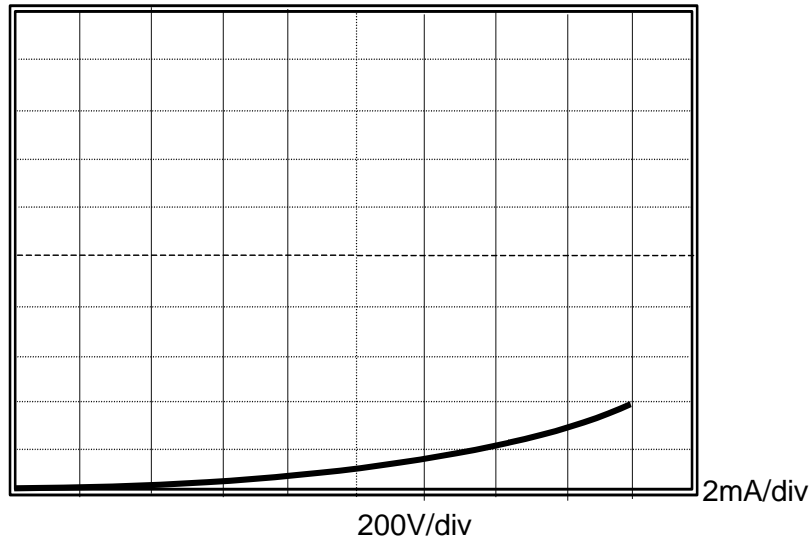

Figure 5: Schematic of a typical blocking leakage current waveform

IXYS Semiconductor GmbH
Edisonstraße 15
D-68623 Lampertheim
Tel: +49 6206 503-0
Fax: +49 6206 503-627
E-mail: marcom@ixys.de



IXYS UK Westcode Ltd
Langley Park Way, Langley Park,
Chippenham, Wiltshire, SN15 1GE.
Tel: +44 (0)1249 444524
Fax: +44 (0)1249 659448
E-mail: sales@ixysuk.com

IXYS Corporation
1590 Buckeye Drive
Milpitas CA 95035-7418
Tel: +1 (408) 457 9000
Fax: +1 (408) 496 0670
E-mail: sales@ixys.net

www.ixysuk.com

www.ixys.net

IXYS Long Beach
IXYS Long Beach, Inc
2500 Mira Mar Ave, Long Beach
CA 90815
Tel: +1 (562) 296 6584
Fax: +1 (562) 296 6585
E-mail: service@ixyslongbeach.com

The information contained herein is confidential and is protected by Copyright. The information may not be used or disclosed except with the written permission of and in the manner permitted by the proprietors IXYS UK Westcode Ltd.

© IXYS UK Westcode Ltd.

In the interest of product improvement, IXYS UK Westcode Ltd reserves the right to change specifications or application notes at any time without prior notice.

Important Notice:

This document is provided by Littelfuse, Inc. ("Littelfuse") for informational and guideline purposes only. Littelfuse assumes no liability for errors or omissions in this document or for any of the information contained herein. Information is provided on an "as is" and "with all faults" basis for evaluation purposes only. Applications described are for illustrative purposes only and Littelfuse makes no representation that such applications will be suitable for the customer's specific use without further testing or modification. Littelfuse expressly disclaims all warranties, whether express, implied or statutory, including but not limited to the implied warranties of merchantability and fitness for a particular purpose, and non-infringement. It is the customer's sole responsibility to determine suitability for a particular system or use based on their own performance criteria, conditions, specific application, compatibility with other components, and environmental conditions. Customers must independently provide appropriate design and operating safeguards to minimize any risks associated with their applications and products.

LITTELFUSE PRODUCTS ARE NOT DESIGNED FOR, AND SHALL NOT BE USED FOR, ANY PURPOSE (INCLUDING, WITHOUT LIMITATION, AUTOMOTIVE, MILITARY, AEROSPACE, MEDICAL, LIFE-SAVING, LIFE-SUSTAINING OR NUCLEAR FACILITY APPLICATIONS, DEVICES INTENDED FOR SURGICAL IMPLANT INTO THE BODY, OR ANY OTHER APPLICATION IN WHICH THE FAILURE OR LACK OF DESIRED OPERATION OF THE PRODUCT MAY RESULT IN PERSONAL INJURY, DEATH, OR PROPERTY DAMAGE) OTHER THAN THOSE EXPRESSLY SET FORTH IN APPLICABLE LITTELFUSE PRODUCT DOCUMENTATION. WARRANTIES GRANTED BY LITTELFUSE SHALL BE DEEMED VOID FOR PRODUCTS USED FOR ANY PURPOSE NOT EXPRESSLY SET FORTH IN APPLICABLE LITTELFUSE DOCUMENTATION. LITTELFUSE SHALL NOT BE LIABLE FOR ANY CLAIMS OR DAMAGES ARISING OUT OF PRODUCTS USED IN APPLICATIONS NOT EXPRESSLY INTENDED BY LITTELFUSE AS SET FORTH IN APPLICABLE LITTELFUSE DOCUMENTATION.