

# 08081400 BATTERY DISCONNECT SWITCHES

200A • SPST • IP67 • M10 Studs



## Description

Marine single pole main battery switch with a metal body. Heavy duty and resistant against corrosion, to be used on heavy trucks, farm tractors, buses, commercial vehicles and especially on boats.

## Features/Benefits

- 200A continuous current rating
- Equipped with rubber protection cap
- Removable handle.
- The "V" shape of the terminals allows easy cable connection.
- Reduces risk of arcing
- Waterproof IP67
- Approved RINA ISO-8846

## Mounting Diagram

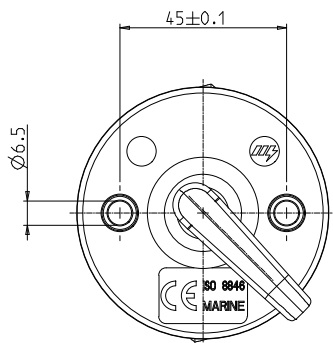

## Specifications

<b>Max Operating Voltage:</b>	24V DC
<b>Max Continuous Current:</b>	200A
<b>Intermittent Current:</b>	1000A at 5 sec
<b>Operating Temp:</b>	-40 °C to +85 °C
<b>Ingress Protection:</b>	IP67
<b>Contacts:</b>	Copper
<b>Terminals:</b>	M10 (brass)
<b>Norm</b>	RINA 8846

## Applications

- Heavy trucks
- Buses
- Commercial vehicles
- Marine

## Web Resources

Download 2D print and technical resources at:  
[littelfuse.com/ManualBatterySwitches](http://littelfuse.com/ManualBatterySwitches)

## Electrical Diagram

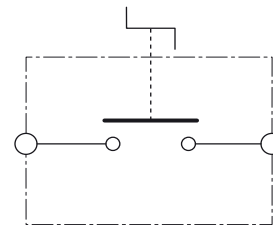

## Ordering Information

PART NUMBER	VOLTAGE	AMPERAGE	CIRCUITRY	MOUNTING	INGRESS	TERMINAL NUTS	NOTES
BOXED							
08081400	12-24V DC	200A	SPST	Through-Hole	IP67	M10 brass	Removable key

# 08081400 BATTERY DISCONNECT SWITCHES

## Dimensions in millimeters

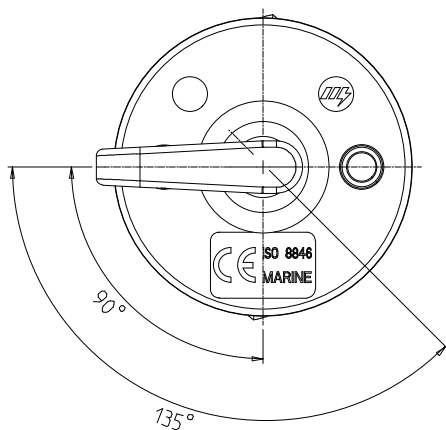
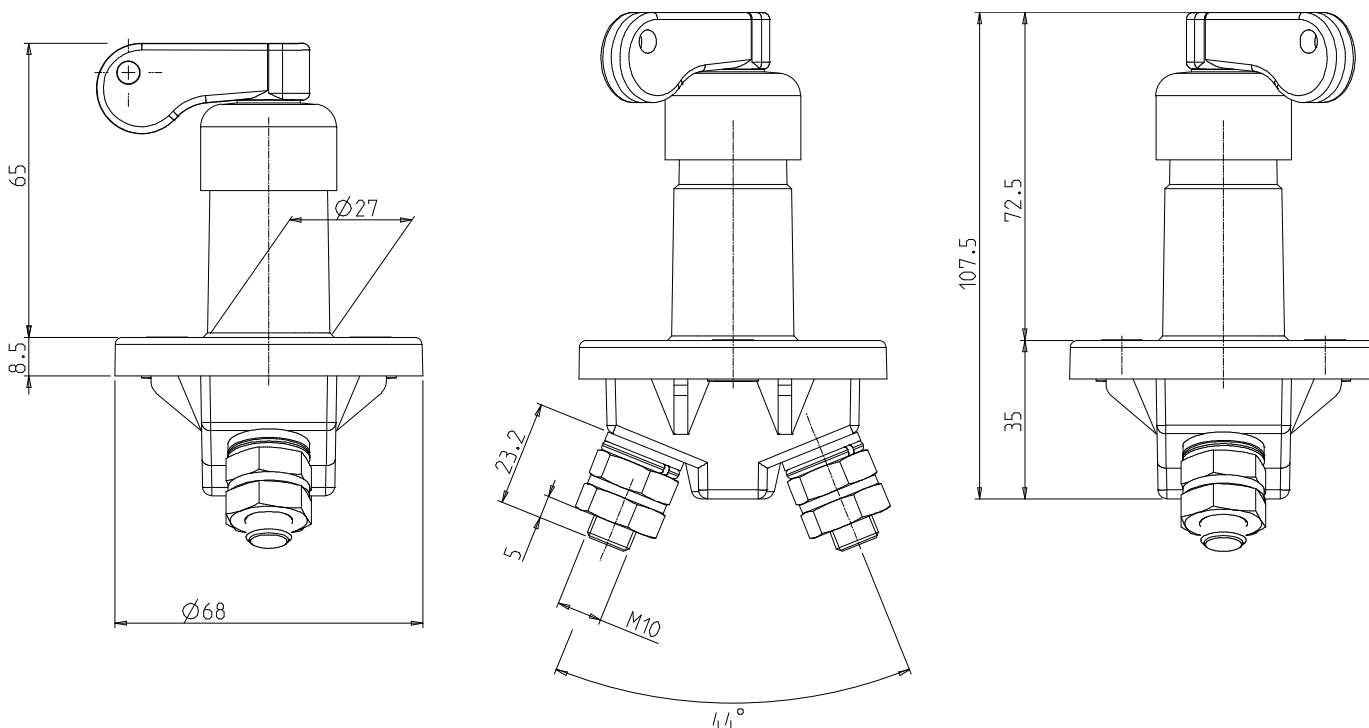

ON position

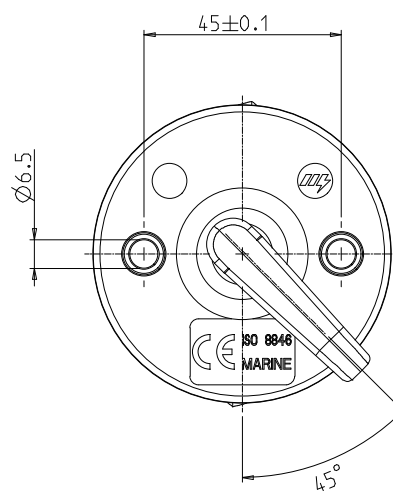

OFF position



Visit [Littelfuse.com](http://Littelfuse.com) for the most up-to-date product information. Littelfuse reserves the right to make product changes, without notice. Material in this document is as accurate as known at the time of publication.