

INSTALLATION INSTRUCTIONS FOR SYMCOM'S MOTORSAVER MODEL 50R-400-ALT ALTERNATING RELAY

**BE SURE POWER IS DISCONNECTED PRIOR TO INSTALLATION!
FOLLOW NATIONAL, STATE AND LOCAL CODES.
READ THESE INSTRUCTIONS ENTIRELY BEFORE INSTALLATION.**

DANGER!



**HAZARDOUS VOLTAGES MAY BE PRESENT DURING INSTALLATION.
Electrical shock can cause death or serious injury.**



Installation should be done by qualified personnel following all national, state and local electrical codes.

The Model 50R-400-ALT alternating relay is used to alternate between two loads, most commonly in duplex pumping and compressor applications to balance the runtime of both loads. The 470VA @ 600VAC pilot duty rated relay eliminates the need for a control power transformer. When used in dual-float applications, the alternating relay will allow both pumps to run simultaneously when both floats are closed.

CONNECTIONS

1. Mount the MotorSaver in a convenient location in or near the motor control panel. If the location is wet or dusty, the MotorSaver should be mounted in a NEMA 4 or 12 enclosure.
2. Connect the lines of the power supply to L1 and L2 on the MotorSaver's terminal strip.
3. Connect the common relay terminal to the main float and CONTROL POWER input on the Model 50R-400-ALT. Connect LOAD 1 and LOAD 2 to the contactor coils as shown in Figure 1.
4. Connect an additional float (optional) to LOAD 1 and LOAD 2. This configuration will allow both pumps to run if both floats are closed.

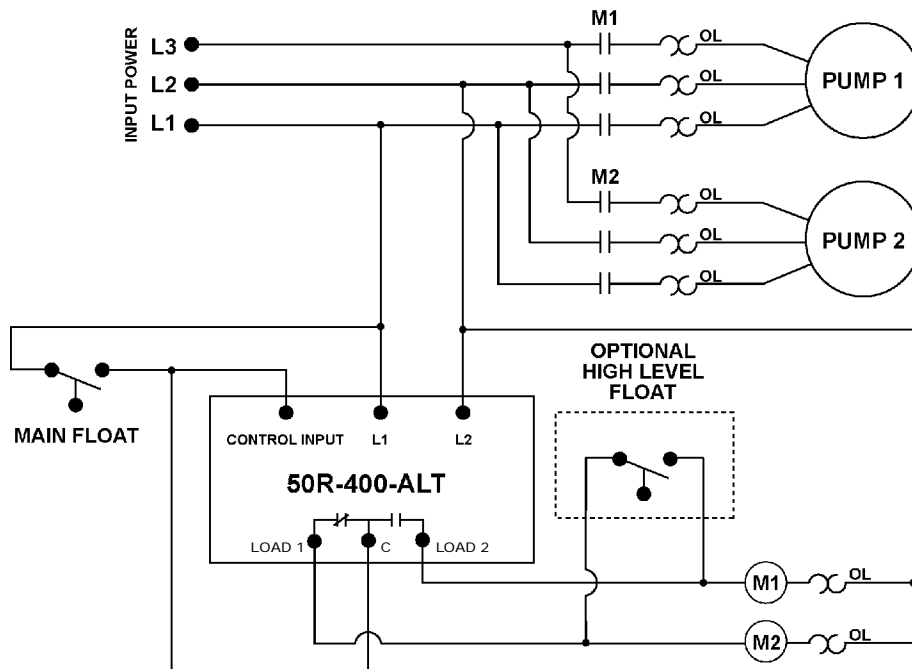

Figure 1. Typical Wiring Diagram for the Model 50R-400-ALT

II-50R-400-ALT-B

OPERATION

The Model 50R-400-ALT alternating relay changes state each time the float switch opens. It will not switch states while current is flowing. Switching only occurs after current has been sensed, followed by loss of current for the duration of the debounce time delay. The debounce time delay (1 sec.) feature prevents the alternating relay from changing state if the float contact bounces momentarily.

The Model 50R-400-ALT can be configured to alternate between two pumps or to force one pump to run every time the float closes. This can be useful when removing a pump for maintenance or repair.

In dual-float applications, the alternating relay will allow both pumps to run simultaneously when both floats are closed.

MODEL 50R-400-ALT SPECIFICATIONS	
Input Voltage	380-480VAC, single-phase
Frequency	*50/60Hz
Supply Current	40mA
Control Input Impedance	1MΩ
Contact Rating	470VA @ 600VAC
General Purpose Relay Rating	10A
Debounce Time Delay	1 second
Power Consumption	5 Watts (max.)

*50Hz will increase all delay timers by 20%

DIMENSIONS

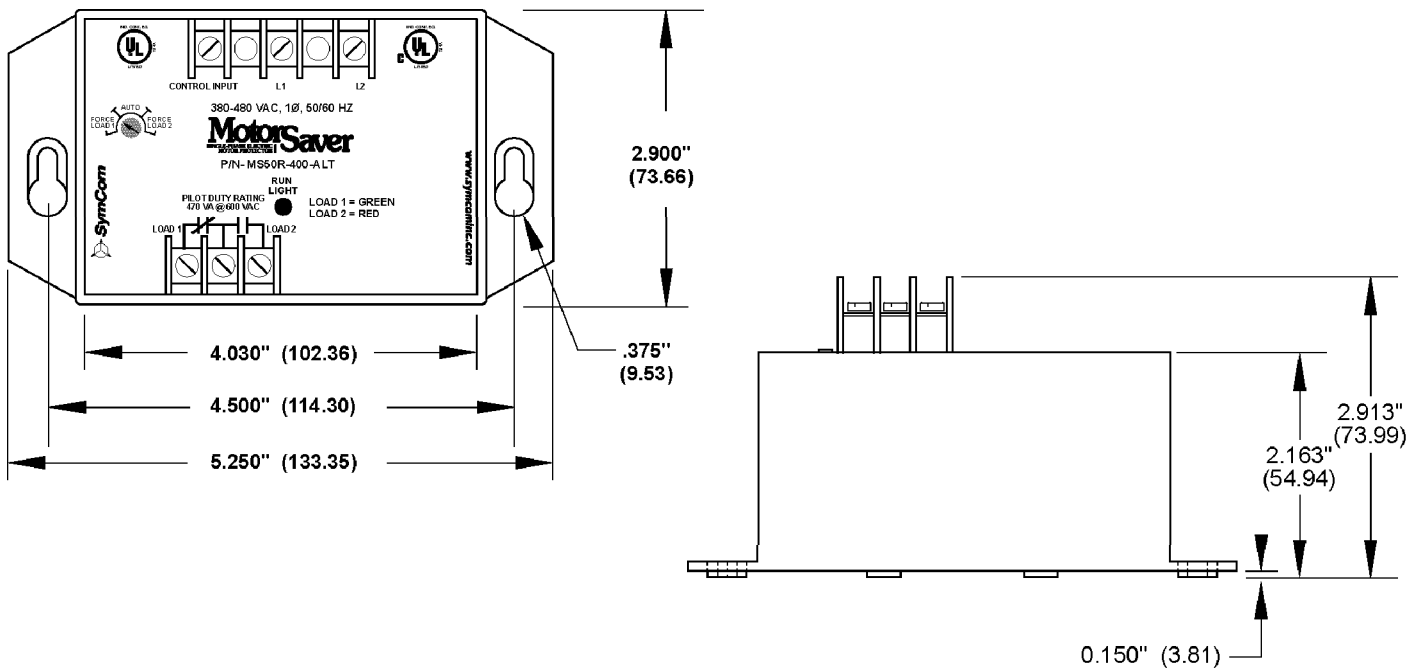

SymCom Warrants its microcontroller based products against defects in material or workmanship for a period of five (5) years from the date of manufacture. All other products manufactured by SymCom shall be warranted against defects in material and workmanship for a period of two (2) years from the date of Manufacture. For complete information on warranty, liability, terms, returns, and cancellations, please refer to the SymCom Terms and Conditions of Sale document.