

OPERATION

Normal operation:

Remote ON and Remote OFF switches are used to control the mail contact bridges

BSAFE Startup:

When the installation is completed, make sure that the vehicle key is off, rotate the handle from OFF to READY and check that there is no voltage on the vehicle load (contacts open). Then apply a remote or local ON (via pushbutton) and check that now there is a battery voltage applied to the vehicle load.

Insert the key and switch ON the dashboard: all light indications must be correctly activated, then switch on the engine and check that all is OK.

The handle always allows to open contacts, when rotated to OFF: it only does that. It is not an alternative of the remote ON (C1-4) and OFF (C1-3) commands. It must be used only when a manual off-vehicle battery cut off is really needed. When the handle is taken again to READY, it is necessary to push the local ON button (or apply a remote ON), in order to restore the BSAFE in a fully working switch ON.

Use of handle:

Batteries status	good			low	
	+15 IGN status	activated	activated	deactivated	(any)
actions in sequence:	activated	activated	deactivated	(any)	(any)
1. rotating handle READY to OFF: <i>(1b. external operation.)</i>	bridges open	bridges open	bridges open	bridges open	bridges open
2. rotating handle OFF to READY:	bridges closed	bridges open after a short closing state	bridges stay open	bridges open after a short closing state	bridges closed
3. LED status:	ON	single blinking, then OFF	OFF	single blinking, then OFF	triple blinking (see >L7)
4. pushing local ON button:	(not needed)	bridges closed	bridges closed	bridges closed	(not needed)



BEFORE to apply maintenance on cables be sure that the handle is in OFF position when you remove it!

LVM activation

Initiate LVM (possible only after a few OFF-ON cycles to verify installation):

- Turn Handle from READY to OFF (starting from ON or OFF status of bridges)
- within 1sec, press and hold local ON button for at least 10sec.
- There will be a blinking during 15sec, to confirm LVM is activated.
- Turn handle from OFF to READY

LVM initialization will be cancelled if battery voltage is absent.

Notice! It is very important to connect C2:7 to a signal which is at Battery Positive voltage when the truck is running, such as IGNition. Otherwise, in case of faulty alternator, the LVM function, if initialized, may cause a lack of electric power while truck is running.

TROUBLE SHOOTING

Diagnosis

LED indications:

- >L1: Continuously illuminated Main contacts bridges are closed (ON)
 - >L2: Continuously turned off Main contacts bridges are open (OFF) (after ECM shut-off)
 - >L3: Fast blinking for ~15sec LVM initialization procedure has been performed with success.
 - >L4: Blinking long illumination ECM output overcurrent has been detected (check load on C1:2)
 - >L5: Blinking short illumination Battery is low and LVM will open main contact bridges
 - >L6: Double Blink iROS test has failed (no command registered on C2:2, check connection)
 - >L7: Triple Blink Operation of main contact bridges has failed (check battery, connections)
- Pressing the local push-button, even very shortly, will cancel the LED ERROR code.
- >L8 If any of above situations are not present and the LED presents another blinking, then it may be repeating the STATUS code from iROS on Input on C2:4 (see related documentation)

The BSAFE can detect a false OFF (C1-3) or ON (C1-4) command, because of faulty contact inside switches or connections (water ingress or oxide action). In this case the command will be discarded, until a real change from a "good insulation" state to a "clear closed circuit" state will be detected.

Test iROS:

Make sure Handle is in READY position, then press (main contact bridges will close if they were open) and hold local ON button for ~10". After these 10" the iROS device starts the test and main contact bridges should open (if test is successful). Release the ON button when you notice contact bridges are opening.

Used « stand-alone », without any harness, using only local commands:

- ONLY FOR BIPOLAR (+/-) VERSIONS! -

Switch OFF main bridges by turning Handle to the position that triggers switch-off, then turn back to READY. Switch ON main bridges by pressing (while Handle at READY) the local ON button. Don't wire C2:7 to permanent plus, it would inhibit the electrical switch-off activated by the handle.

MEMBER'S S.p.A. is not liable for any damage that can, directly or indirectly, affect persons, objects and pets as a consequence of failure to comply with the prescriptions indicated in this manual. MEMBER'S reserves the right to change the features and data stated in the following manual at any time without forewarning, in order to improve its products. This manual cannot be considered as a contract for third parties.

cod. 80173534 rev. A - February 2013

INSTALLATION MANUAL



INSTALLATION

Mechanical fixation:

Use 4 holes on chassis, mount inserts (1) according to footprint/orientation, use M8 screws @ 18 Nm.

Any orientation is possible but upside down. If DIN connectors point UP please note the warning in the picture

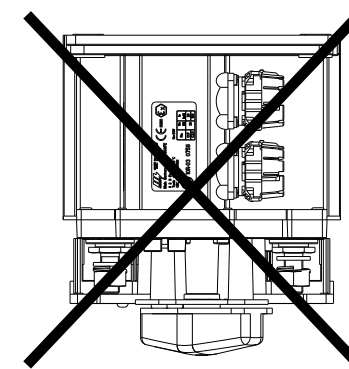

Power connections:

If handle (4) is mounted; Rotate Handle to OFF position, then unscrew and remove handle.

1. Choose cable orientation and accordingly break isolating barriers on protecting cover (2).

From base to top: terminal lug, plain washer, spring washer, nut. Fasten at a torque of 18 Nm

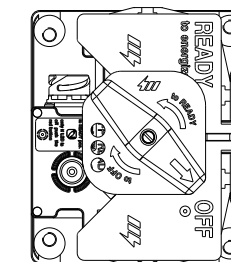
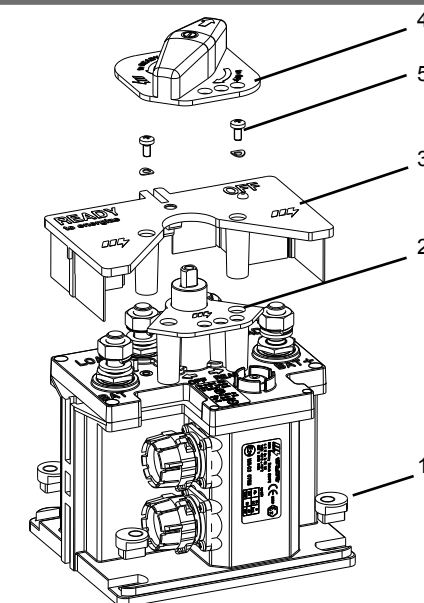

WARNING: if it's mounted with DIN connectors pointed up you need watertight wiring or caps

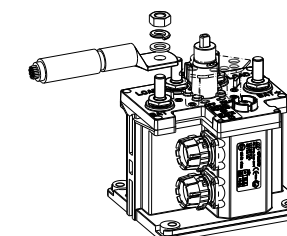



- > Connect Battery positive on « BAT+ » stud, and Load positive on « Load+ » stud
 - > For Double Positive versions:
 - > 2nd battery positive-cable on «BAT» stud, 2nd load positive on «LOAD» stud.
 - > For Bipolar versions:
 - > Battery minus cable on «BAT» stud. Load negative on «LOAD» stud.
2. Mount the protecting cover (2) by inserting/clicking the leg on the back of the top cover and fastening the screws (5).
 3. Optionally mount padlock support (3).
 4. Mount and screw the handle (4) (don't force to insert on the wrong side, see correct orientation as per following picture: three holes are on same side of ON push-button)

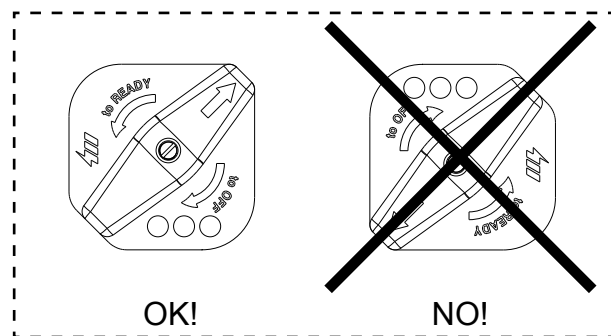
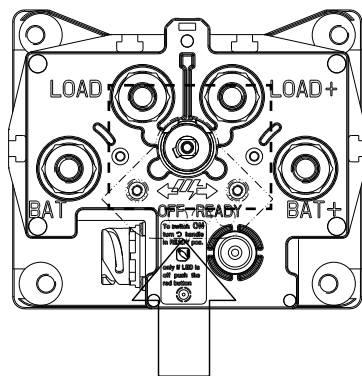

FEATURES & RECOMMANDATIONS

Characteristic	Ref.	Value	Unit	Conditions
Voltage				
Voltage range (Um < 30V for Ex application)	V _N	9 30	V	12V or 24V automatically detected
Current rating				
Max. continuous current rating	I _{Mc}	2x300	A	23°C
Max. short duration current rating	I _{Mb(5)}	1500	A	23°C - 5s
Environmental characteristics				
Temperature range	T _F	-40 ÷ +70	°C	
IP protection (ISO 20653:2006)	IP	IP69K	-	Bsafe body
		IP54	-	contact protection

An external 10A-fuse has to be used (see C1-5 in "Wiring")

Safeguard this booklet for future use.

This packaging is potentially dangerous and must not be left within reach of children. This device must not be used by children or persons not trained in its use. This device must be used only for the purpose for which it was expressly designed, any other use is considered improper use and, therefore, dangerous. No serviceable parts inside.

Contents of BSafe box:

- 1 BSafe main unit, 1 protection cover, 1 triple padlock bracket
- 1 handle, 1 bag with 4 threaded inserts
- 1 bag with 4 M4 screws + 4 spring washers + 3 M6 bolts and nuts
- 1 bag with 4 nuts M10 + 4 plain washers + 4 spring washers
- 1 Installation manual (this one), 1 Safety Note.

GLOSSARY

ECM: Electronic Control Module. Generic electronic device which can be fed through the battery main switch, with a delayed switch OFF (10"), in order to allow it to perform any afterrun task, after BSAFE contacts opening.

IGN: Ignition line or dashboard key line or +15 line.

iROS: Rolling over detection device. This device, when a vehicle rolling over is detected, sends an emergency switch OFF command to the battery main switch.

LVM: Low Voltage Monitoring. When a low level voltage is detected as persisting for more than 90sec, contacts are open automatically. This function must be enabled (see LVM activation) and can be inhibited by an external command on C2:7 line (non-active when the vehicle is running). Voltage thresholds are 11,4V and 22,8V in 12V and 24V systems respectively



WIRING

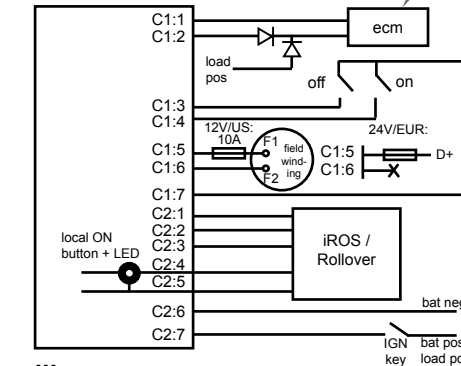
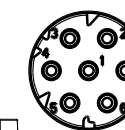
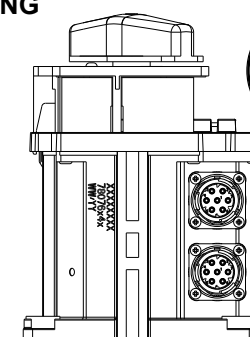

Signal and auxiliary power

C1-1: Supply GND (negative) output for ECM. Max continuous amperage 1,5A

C1-2: Positive supply output for the ECM. Max continuous amperage 1,5A

C1-3: Input for remote OFF control switch, command active when at battery positive

C1-4: Input for remote ON control switch, command active when at battery positive

C1-5: Field winding isolation (will occur ~140msec before main circuit opens).

USE AN EXTERNAL 10A FUSE.

For European style:
>C1-5 should be connected on positive side; "D+" (and C1:6 not connected)

C1-6: For American style field isolation, the field circuit must be open and put in series with C1-6 and C1-5, by negative side of winding.

>When main bridges are closed, C1-5 is internally (inside Bsafe) connected to C1-6

>When main bridges are open, C1-5 is internally (inside Bsafe) connected battery negative, which on Double Positive versions comes internally from C2-6 and which on Bipolar versions comes internally from 'BAT' stud.)

C1-7: Output battery positive for external remote control switches. To be used ONLY to control the Bsafe

C2-1: is the Supply GND output for iROS or other rolover device. Max continuous amperage 100mA

C2-2: Input for an emergency OFF command, such as an iROS or other rolover unit or emergency switches.

> To use multiple units/switches, **they must be active low and, when inactive, must be open state.**

C2-3: is the positive supply output for iROS or other rolover device. Max continuous amperage 100mA

C2-4: Input for test feedback / self-diagnosis LED of iROS. Connect to iROS warning light output (see L8 below)

C2-5: Output for test activation. This should go to iROS test inputs

C2-6: GND (battery negative) input for Double Positive versions (pin not mounted on Bipolar versions)

>For Bipolar versions make sure a dummy seal (and no pin) is in mating connector's cavity 6.

C2-7: Input disabling LVM and electrical switch-off triggered by handle

It is recommended to use IGN here