

Pulse Thyristor

Type Y500CNC250

Absolute Maximum Ratings

	VOLTAGE RATINGS	MAXIMUM LIMITS	UNITS
V _{DRM}	Repetitive peak off-state voltage, (note 1)	2500	V
V _{DSM}	Non-repetitive peak off-state voltage, (note 1)	2500	V
V _{R RM}	Repetitive peak reverse voltage, (note 1)	2000	V
V _{R SM}	Non-repetitive peak reverse voltage, (note 1)	2100	V
V _{DC}	Permanent dc voltage	1500	V

	OTHER RATINGS	MAXIMUM LIMITS	UNITS
I _{TM}	Maximum pulse current, (note 2)	50	kA
I ² t	Load limit integral, (note 2)	312.5×10 ³	A ² s
I _{T(AV)M}	Maximum average on-state current. T _{sink} =85°C, (note 3)	480	A
(di/dt) _{cr}	Critical rate of rise of on-state current (non-repetitive), (Note 4)	11	kA/μs
V _{RGM}	Peak reverse gate voltage	18	V
T _{J op}	Operating temperature range	-40 to +125	°C
T _{stg}	Storage temperature range	-40 to +150	°C

Notes:-

- 1) V_{GK}=-2V
- 2) T_J=125°C, half-sinewave, t_{p(max)}=250μs
- 3) Double side cooled, single phase; 50Hz, 180° half-sinewave.

Characteristics

	PARAMETER	MIN.	TYP.	MAX.	TEST CONDITIONS (Note 1)	UNITS
V_{TM}	Maximum peak on-state voltage	-	-	10	$I_G=4A, I_{TM}=10000A$	V
V_{T0}	Threshold voltage	-	-	1.755		V
r_T	Slope resistance	-	-	1.122		m Ω
$(dv/dt)_{cr}$	Critical rate of rise of off-state voltage	1000	-	-	$V_D=67\% V_{DRM}$, Linear ramp, $V_{GK}=-2V$	V/ μ s
I_{DRM}	Peak off-state current	-	-	100	Rated V_{DRM}	mA
I_{RRM}	Peak reverse current	-	-	100	Rated V_{RRM}	mA
I_L	Latching current	-	10	-	$T_j=25^\circ C$	A
I_H	Holding current	-	10	-		A
I_{GT}	Nominal gate trigger current	-	-	50	$di_G/dt=100A/\mu s, T_j=25^\circ C$	A
t_{gd}	Gate controlled turn-on delay time	-	0.9	-	$V_D=1500V, I_{TM}=25kA, di/dt=5500A/\mu s,$	μ s
t_{gt}	Turn-on time	-	1.0	-	$I_{FG}=50A, di_G/dt=100A/\mu s, T_j=25^\circ C.$	
R_{thJK}	Thermal resistance, junction to heatsink	-	-	0.027	Double side cooled	K/W
		-	-	0.045	Anode side cooled	K/W
		-	-	0.07	Cathode side cooled	K/W
F	Mounting force	15	-	25		kN
W_t	Weight	-	480	-		g

Notes:-

 1) Unless otherwise indicated $T_j=125^\circ C$.

Outline Drawing & Ordering Information

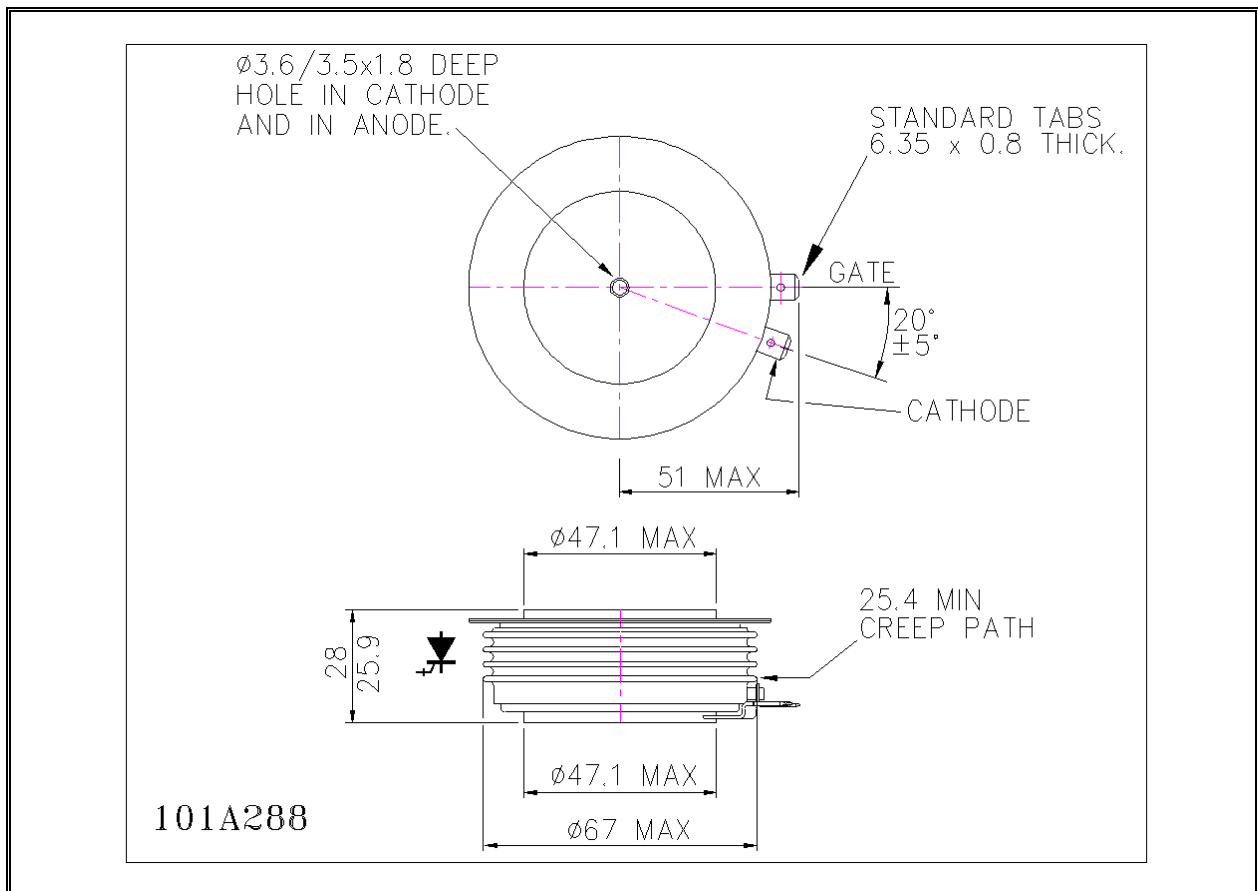

ORDERING INFORMATION			
(Please quote 10 digit code as below)			
Y500C	NC	◆◆	0
Fixed Type Code	Fixed Outline Code	Fixed Voltage Code $V_{DRM}/100$ 25	Fixed code

Typical order code: Y500CNC250 – 2500V V_{DRM} , 28mm clamp height capsule.

IXYS Semiconductor GmbH
Edisonstraße 15
D-68623 Lampertheim
Tel: +49 6206 503-0
Fax: +49 6206 503-627
E-mail: marcom@ixys.de



IXYS UK Westcode Ltd
Langley Park Way, Langley Park,
Chippenham, Wiltshire, SN15 1GE.
Tel: +44 (0)1249 444524
Fax: +44 (0)1249 659448
E-mail: sales@ixysuk.com

IXYS Corporation
1590 Buckeye Drive
Milpitas CA 95035-7418
Tel: +1 (408) 457 9000
Fax: +1 (408) 496 0670
E-mail: sales@ixys.net

www.ixysuk.com

www.ixys.com

IXYS Long Beach
IXYS Long Beach, Inc
2500 Mira Mar Ave, Long Beach
CA 90815
Tel: +1 (562) 296 6584
Fax: +1 (562) 296 6585
E-mail: service@ixyslongbeach.com

The information contained herein is confidential and is protected by Copyright. The information may not be used or disclosed except with the written permission of and in the manner permitted by the proprietors IXYS UK Westcode Ltd.

© IXYS UK Westcode Ltd.

In the interest of product improvement, IXYS UK Westcode Ltd reserves the right to change specifications at any time without prior notice.

Devices with a suffix code (2-letter, 3-letter or letter/digit/letter combination) added to their generic code are not necessarily subject to the conditions and limits contained in this report.



Disclaimer Notice - Information furnished is believed to be accurate and reliable. However, users should independently evaluate the suitability of and test each product selected for their own applications. Littelfuse products are not designed for, and may not be used in, all applications. Read complete Disclaimer Notice at www.littelfuse.com/disclaimer-electronics.