

### GenX3™ 600V IGBTs

### IXGK320N60B3 IXGX320N60B3

$$V_{CES} = 600V$$

$$I_{C90} = 320A$$

$$V_{CE(sat)} \leq 1.6V$$

Medium-Speed Low-V<sub>sat</sub> PT  
IGBTs for 5-40 kHz Switching

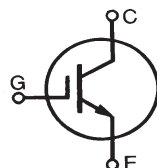

| Symbol         | Test Conditions   | Maximum Ratings       |            |
|----------------|---|-----------------------|------------|
| $V_{CES}$      | $T_J = 25^\circ C$ to $150^\circ C$                       | 600                   | V          |
| $V_{CGR}$      | $T_J = 25^\circ C$ to $150^\circ C$ , $R_{GE} = 1M\Omega$ | 600                   | V          |
| $V_{GES}$      | Continuous  | $\pm 20$              | V          |
| $V_{GEM}$      | Transient   | $\pm 30$              | V          |
| $I_{C25}$      | $T_C = 25^\circ C$ ( Chip Capability )                    | 500                   | A          |
| $I_{C90}$      | $T_C = 90^\circ C$  | 320                   | A          |
| $I_{LRMS}$     | Terminal Current Limit                                    | 160                   | A          |
| $I_{CM}$       | $T_C = 25^\circ C$ , 1ms                                  | 1200                  | A          |
| <b>SSOA</b>    | $V_{GE} = 15V$ , $T_{VJ} = 125^\circ C$ , $R_G = 1\Omega$ | $I_{CM} = 320$        | A          |
| <b>(RBSOA)</b> | Clamped Inductive Load                                    | $V_{CE} \leq V_{CES}$ | V          |
| $P_C$          | $T_C = 25^\circ C$  | 1700                  | W          |
| $T_J$          |   | -55 ... +150          | $^\circ C$ |
| $T_{JM}$       |   | 150                   | $^\circ C$ |
| $T_{stg}$      |   | -55 ... +150          | $^\circ C$ |
| $T_L$          | Maximum Lead Temperature for Soldering                    | 300                   | $^\circ C$ |
| $T_{SOLD}$     | 1.6 mm (0.062 in.) from Case for 10                       | 260                   | $^\circ C$ |
| $M_d$          | Mounting Torque ( IXGK )                                  | 1.13/10               | Nm/lb.in.  |
| $F_C$          | Mounting Force ( IXGX )                                   | 20..120/4.5..27       | N/lb.      |
| <b>Weight</b>  | TO-264  | 10                    | g          |
|                | PLUS247   | 6                     | g          |

TO-264 (IXGK)

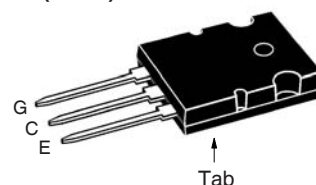

PLUS247 (IXGX)

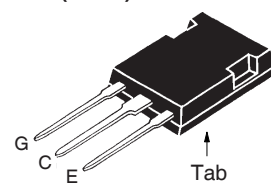

G = Gate                      E = Emitter  
C = Collector                Tab = Collector

### Features

- Optimized for Low Conduction and Switching Losses
- High Current Capability
- Square RBSOA

### Advantages

- High Power Density
- Low Gate Drive Requirement

### Applications

- Power Inverters
- UPS
- Motor Drives
- SMPS
- PFC Circuits
- Battery Chargers
- Welding Machines
- Lamp Ballasts

| Symbol        | Test Conditions<br>( $T_J = 25^\circ C$ , Unless Otherwise Specified) | Characteristic Values |            |                    |
|---------------|---|-----------------------|------------|--------------------|
|               |   | Min.                  | Typ.       | Max.               |
| $BV_{CES}$    | $I_C = 1mA$ , $V_{GE} = 0V$   | 600                   |            | V                  |
| $V_{GE(th)}$  | $I_C = 4mA$ , $V_{CE} = V_{GE}$                                       | 3.0                   |            | 5.0 V              |
| $I_{CES}$     | $V_{CE} = V_{CES}$ , $V_{GE} = 0V$<br>$T_J = 125^\circ C$             |                       |            | 75 $\mu A$<br>2 mA |
| $I_{GES}$     | $V_{CE} = 0V$ , $V_{GE} = \pm 20V$                                    |                       |            | $\pm 400$ nA       |
| $V_{CE(sat)}$ | $I_C = 100A$ , $V_{GE} = 15V$ , Note 1<br>$I_C = 320A$                |                       | 1.4<br>2.0 | 1.6 V<br>V         |

| Symbol   | Test Conditions<br>( $T_J = 25^\circ\text{C}$ , Unless Otherwise Specified)  | Characteristic Values |       |  |
|--|--|-----------------------|-------|--|
|  |  | Min.                  | Typ.  | Max.                                     |
| $g_{fs}$   | $I_C = 60\text{A}, V_{CE} = 10\text{V}$ , Note 1   | 70                    | 125   | S  |
| $C_{ies}$<br>$C_{oes}$<br>$C_{res}$  | $V_{CE} = 25\text{V}, V_{GE} = 0\text{V}, f = 1\text{MHz}$   |                       | 18    | nF                                       |
|  |  |                       | 960   | pF                                       |
|  |  |                       | 130   | pF                                       |
| $Q_g$<br>$Q_{ge}$<br>$Q_{gc}$  | $I_C = 320\text{A}, V_{GE} = 15\text{V}, V_{CE} = 0.5 \cdot V_{CES}$   |                       | 585   | nC                                       |
|  |  |                       | 105   | nC                                       |
|  |  |                       | 215   | nC                                       |
| $t_{d(on)}$<br>$t_{ri}$<br>$E_{on}$<br>$t_{d(off)}$<br>$t_{fi}$<br>$E_{off}$ | <b>Inductive Load, <math>T_J = 25^\circ\text{C}</math></b><br>$I_C = 100\text{A}, V_{GE} = 15\text{V}$<br>$V_{CE} = 0.8 \cdot V_{CES}, R_G = 1\Omega$  |                       | 44    | ns                                       |
|  |  |                       | 66    | ns                                       |
|  |  |                       | 2.7   | mJ                                       |
|  |  |                       | 250   | ns                                       |
|  |  |                       | 165   | ns                                       |
|  |  |                       | 3.5   | 5.0                                      |
| $t_{d(on)}$<br>$t_{ri}$<br>$E_{on}$<br>$t_{d(off)}$<br>$t_{fi}$<br>$E_{off}$ | <b>Inductive Load, <math>T_J = 125^\circ\text{C}</math></b><br>$I_C = 100\text{A}, V_{GE} = 15\text{V}$<br>$V_{CE} = 0.8 \cdot V_{CES}, R_G = 1\Omega$ |                       | 40    | ns                                       |
|  |  |                       | 67    | ns                                       |
|  |  |                       | 3.5   | mJ                                       |
|  |  |                       | 330   | ns                                       |
|  |  |                       | 265   | ns                                       |
|  |  |                       | 5.4   | mJ                                       |
| $R_{thJC}$<br>$R_{thCS}$   |  | 0.15                  | 0.073 | $^\circ\text{C/W}$<br>$^\circ\text{C/W}$ |

### TO-264 AA (IXGK) Outline

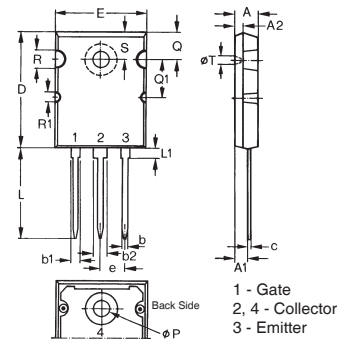

| Dim. | Millimeter |       | Inches   |       |
|------|------------|-------|----------|-------|
|      | Min.       | Max.  | Min.     | Max.  |
| A    | 4.82       | 5.13  | .190     | .202  |
| A1   | 2.54       | 2.89  | .100     | .114  |
| A2   | 2.00       | 2.10  | .079     | .083  |
| b    | 1.12       | 1.42  | .044     | .056  |
| b1   | 2.39       | 2.69  | .094     | .106  |
| b2   | 2.90       | 3.09  | .114     | .122  |
| c    | 0.53       | 0.83  | .021     | .033  |
| D    | 25.91      | 26.16 | 1.020    | 1.030 |
| E    | 19.81      | 19.96 | .780     | .786  |
| e    | 5.46 BSC   |       | .215 BSC |       |
| J    | 0.00       | 0.25  | .000     | .010  |
| K    | 0.00       | 0.25  | .000     | .010  |
| L    | 20.32      | 20.83 | .800     | .820  |
| L1   | 2.29       | 2.59  | .090     | .102  |
| P    | 3.17       | 3.66  | .125     | .144  |
| Q    | 6.07       | 6.27  | .239     | .247  |
| Q1   | 8.38       | 8.69  | .330     | .342  |
| R    | 3.81       | 4.32  | .150     | .170  |
| R1   | 1.78       | 2.29  | .070     | .090  |
| S    | 6.04       | 6.30  | .238     | .248  |
| T    | 1.57       | 1.83  | .062     | .072  |

Note 1. Pulse test,  $t \leq 300\mu\text{s}$ , duty cycle,  $d \leq 2\%$ .

### PRELIMINARY TECHNICAL INFORMATION

The product presented herein is under development. The Technical Specifications offered are derived from data gathered during objective characterizations of preliminary engineering lots; but also may yet contain some information supplied during a pre-production design evaluation. IXYS reserves the right to change limits, test conditions, and dimensions without notice.

### PLUS247™ (IXGX) Outline

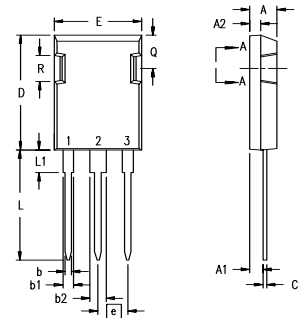

Terminals: 1 - Gate  
2 - Collector  
3 - Emitter

| Dim.           | Millimeter |       | Inches   |       |
|----------------|------------|-------|----------|-------|
|                | Min.       | Max.  | Min.     | Max.  |
| A              | 4.83       | 5.21  | .190     | .205  |
| A <sub>1</sub> | 2.29       | 2.54  | .090     | .100  |
| A <sub>2</sub> | 1.91       | 2.16  | .075     | .085  |
| b              | 1.14       | 1.40  | .045     | .055  |
| b <sub>1</sub> | 1.91       | 2.13  | .075     | .084  |
| b <sub>2</sub> | 2.92       | 3.12  | .115     | .123  |
| C              | 0.61       | 0.80  | .024     | .031  |
| D              | 20.80      | 21.34 | .819     | .840  |
| E              | 15.75      | 16.13 | .620     | .635  |
| e              | 5.45 BSC   |       | .215 BSC |       |
| L              | 19.81      | 20.32 | .780     | .800  |
| L1             | 3.81       | 4.32  | .150     | .170  |
| Q              | 5.59       | 6.20  | .220     | 0.244 |
| R              | 4.32       | 4.83  | .170     | .190  |

IXYS Reserves the Right to Change Limits, Test Conditions, and Dimensions.

**Fig. 1. Output Characteristics @  $T_J = 25^\circ\text{C}$**

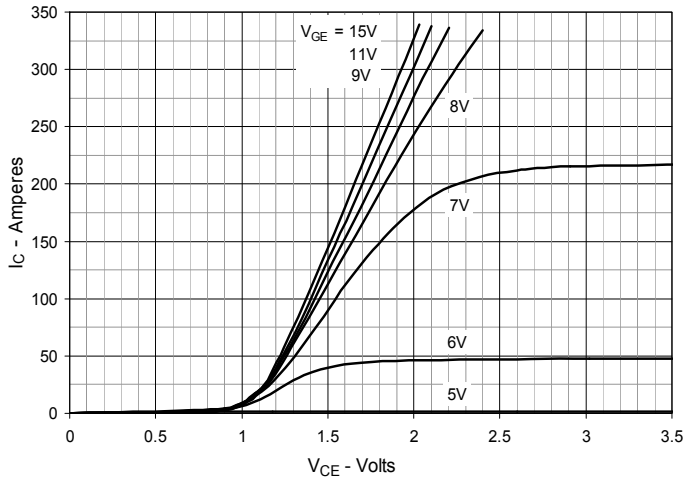

**Fig. 2. Output Characteristics @  $T_J = 125^\circ\text{C}$**

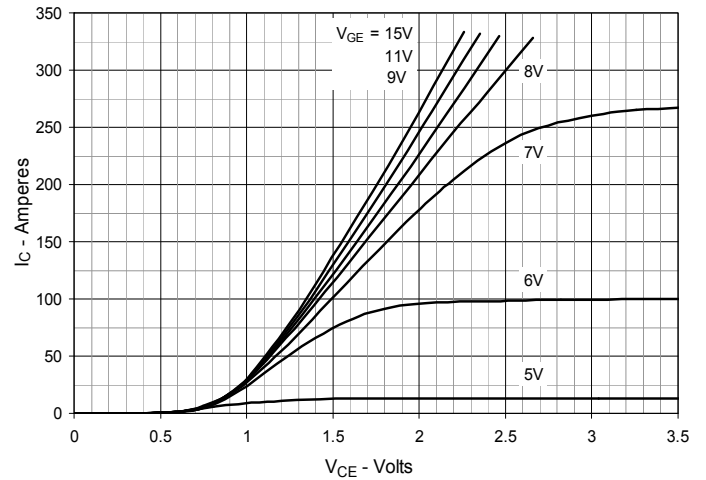

**Fig. 3. Dependence of  $V_{CE(sat)}$  on Junction Temperature**

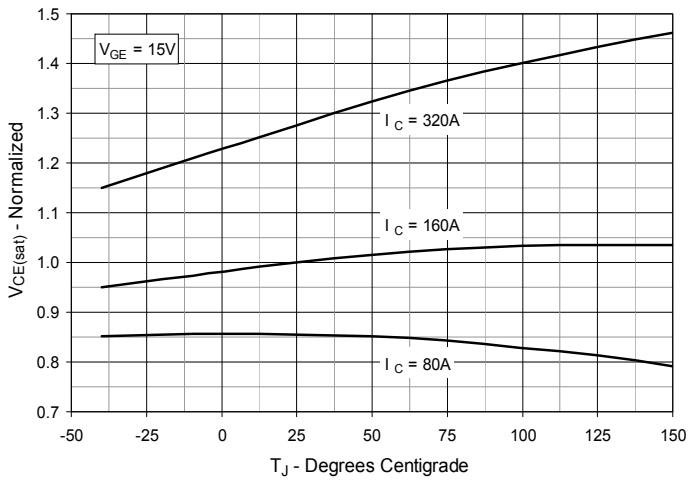

**Fig. 4. Collector-to-Emitter Voltage vs. Gate-to-Emitter Voltage**

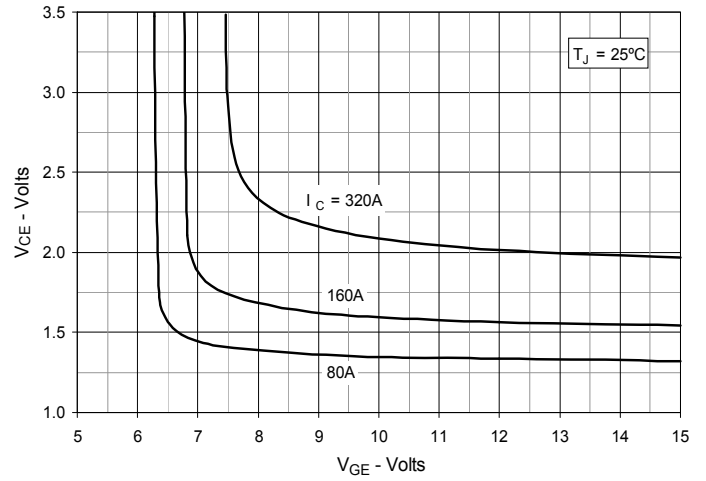

**Fig. 5. Input Admittance**

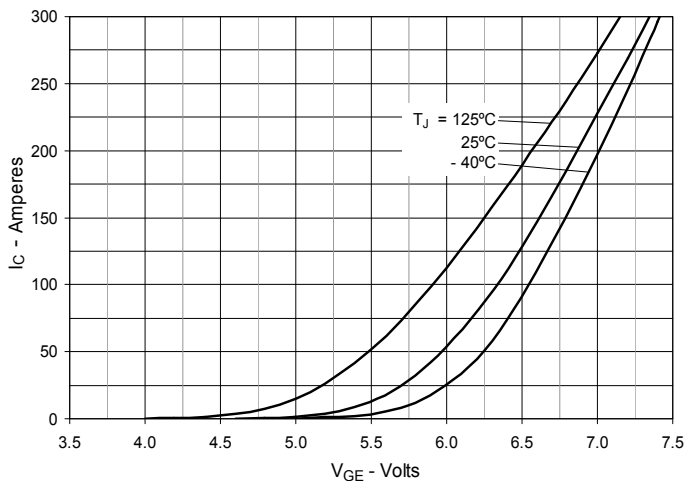

**Fig. 6. Transconductance**

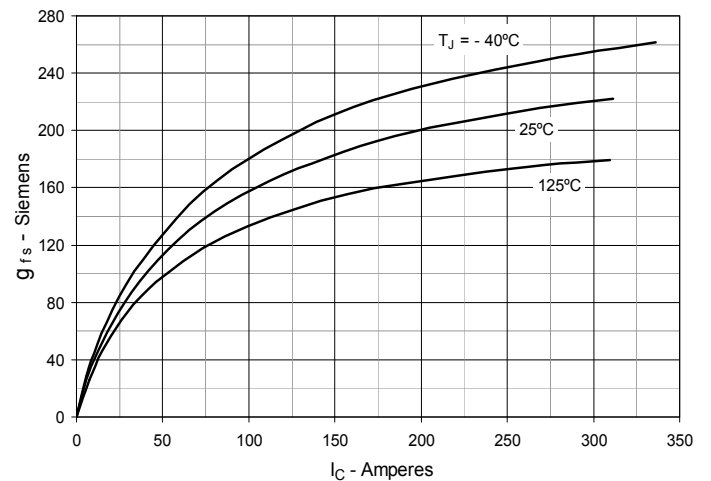

Fig. 7. Gate Charge

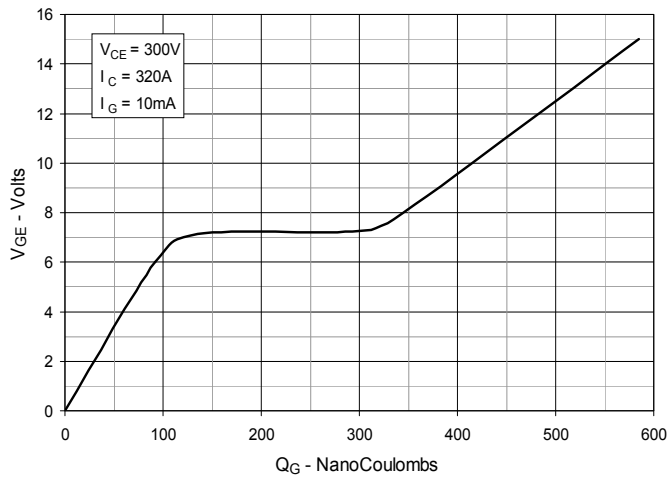

Fig. 8. Capacitance

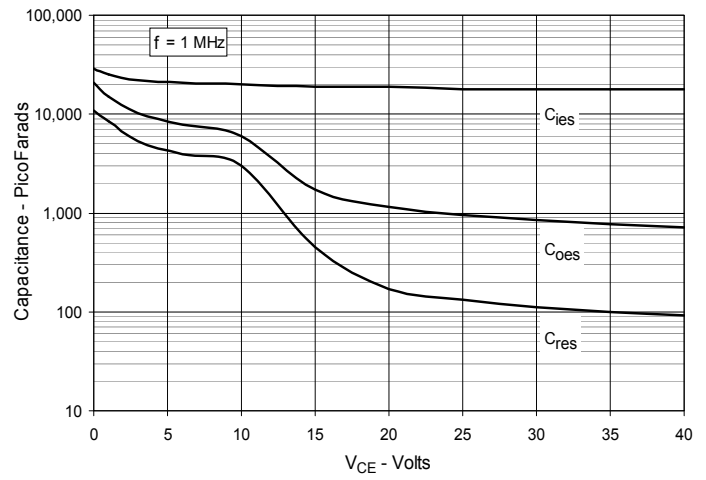

Fig. 9. Reverse-Bias Safe Operating Area

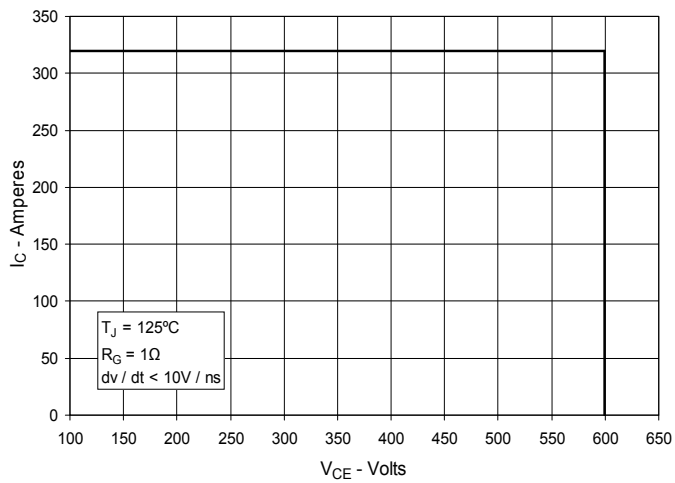
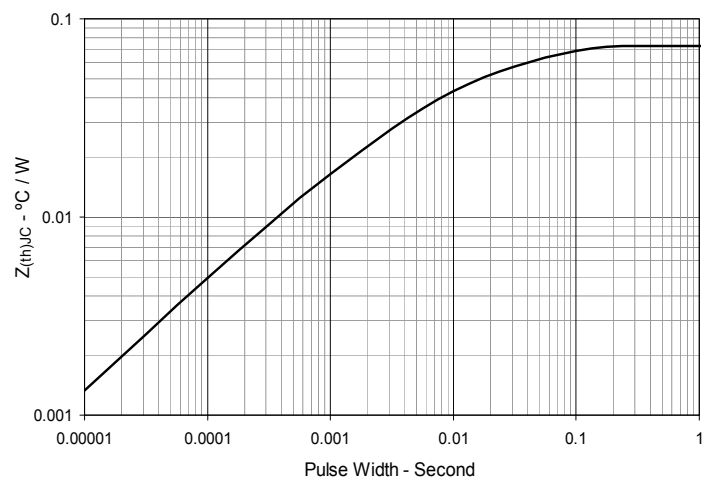
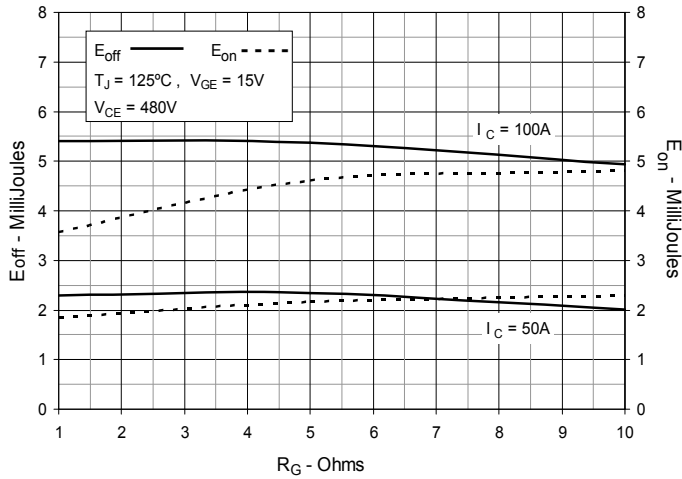

Fig. 10. Maximum Transient Thermal Impedance



**Fig. 11. Inductive Switching Energy Loss vs. Gate Resistance**



**Fig. 12. Inductive Switching Energy Loss vs. Collector Current**

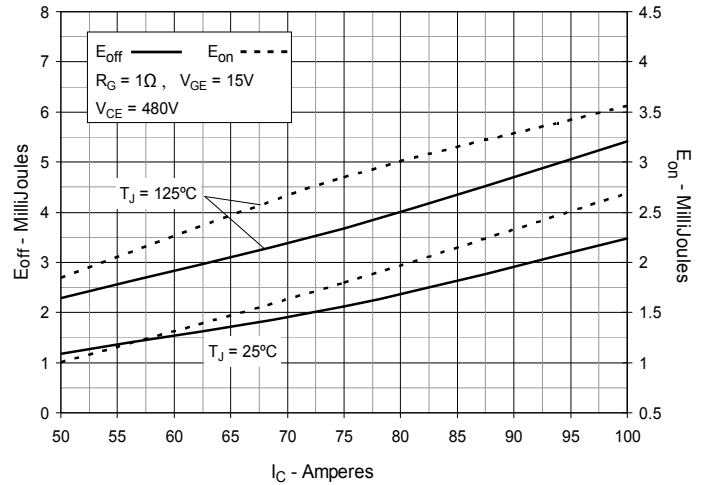

**Fig. 13. Inductive Switching Energy Loss vs. Junction Temperature**

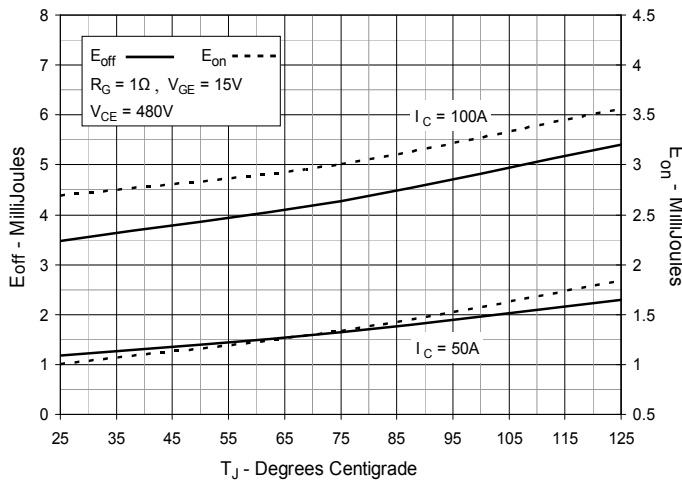

**Fig. 14. Inductive Turn-off Switching Times vs. Gate Resistance**

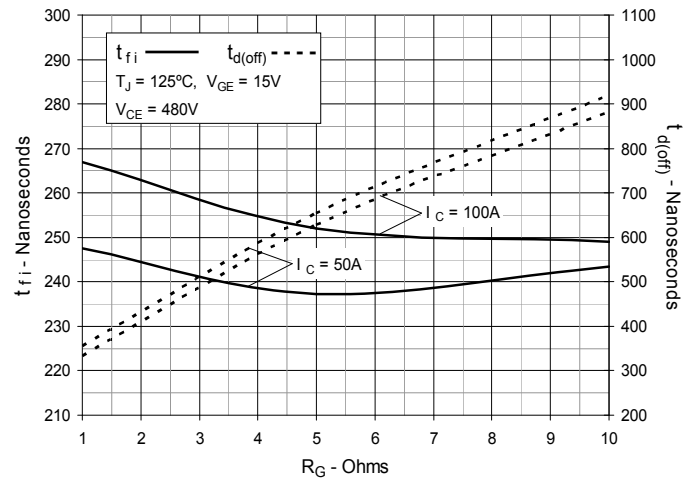

**Fig. 15. Inductive Turn-off Switching Times vs. Collector Current**

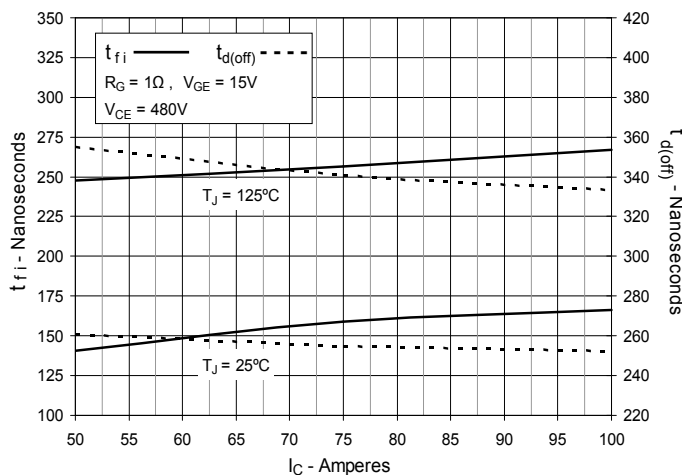

**Fig. 16. Inductive Turn-off Switching Times vs. Junction Temperature**

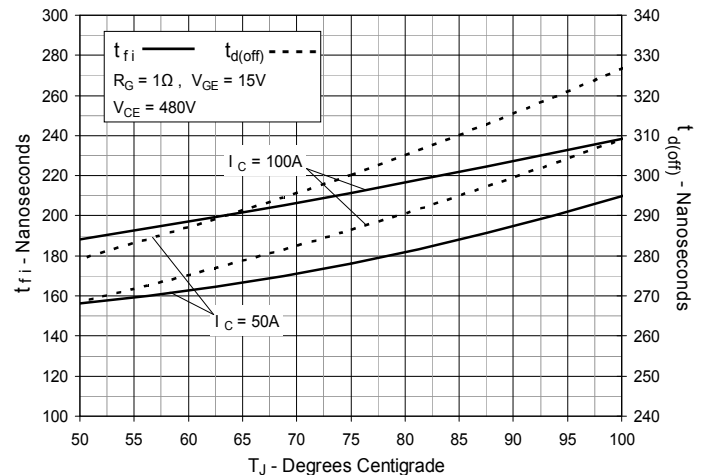

**Fig. 17. Inductive Turn-on**  
**Switching Times vs. Gate Resistance**

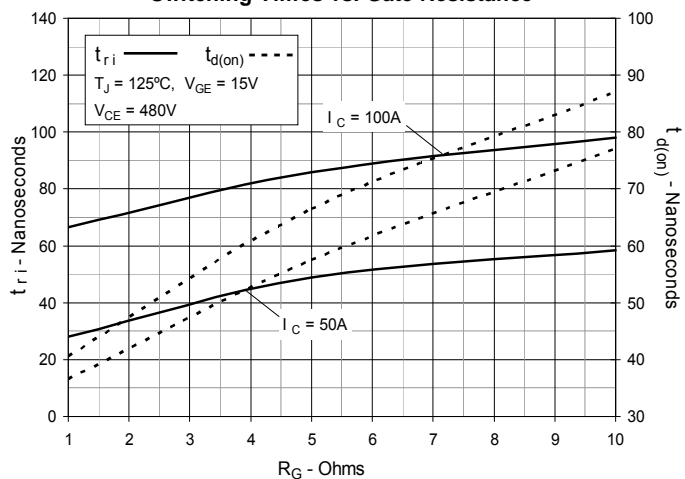

**Fig. 18. Inductive Turn-on**  
**Switching Times vs. Collector Current**

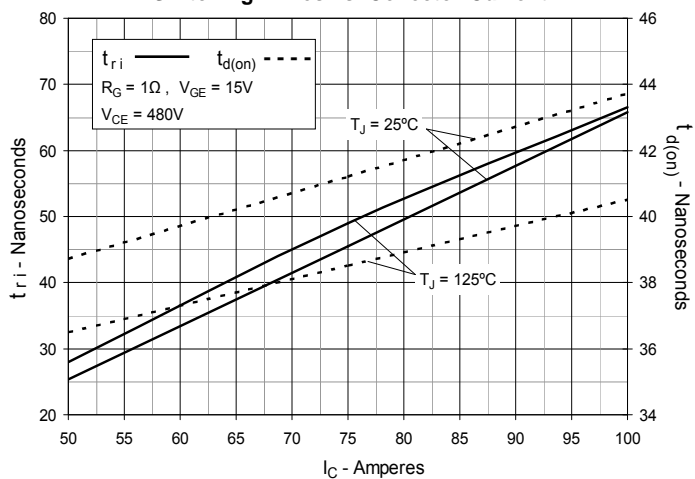

**Fig. 19. Inductive Turn-on**  
**Switching Times vs. Junction Temperature**

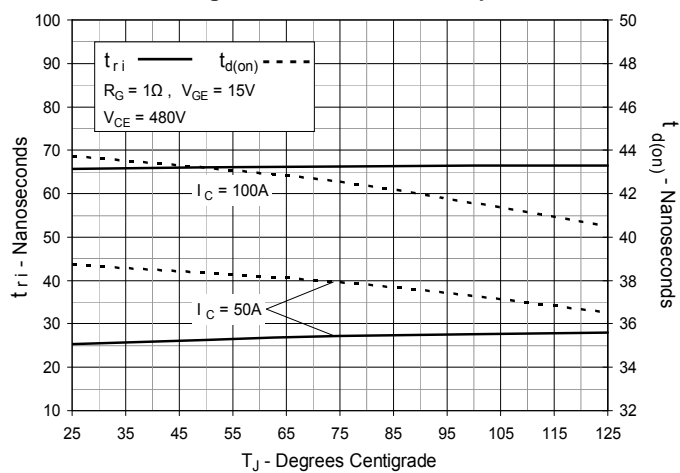



---

Disclaimer Notice - Information furnished is believed to be accurate and reliable. However, users should independently evaluate the suitability of and test each product selected for their own applications. Littelfuse products are not designed for, and may not be used in, all applications. Read complete Disclaimer Notice at [www.littelfuse.com/disclaimer-electronics](http://www.littelfuse.com/disclaimer-electronics).