

# DCNEVT150 SERIES HIGH CURRENT HIGH VOLTAGE DC CONTACTOR RELAY



## Specifications Overview

<b>Amperage:</b>	150A Continuous Carry
<b>Housing:</b>	Nylon UL 94-V0
<b>Voltage Rating:</b>	450V
<b>Connector:</b>	KET090-II, 2-Pole Connector MG651026 Terminal ST730676-3
<b>Ingress Protections:</b>	IP54
<b>Operating Temperature:</b>	-40°C to 85°C
<b>Circuitry:</b>	SPST NO
<b>Coil Voltage:</b>	<b>B:</b> 12V DC Nominal, 9 - 15V DC Working <b>C:</b> 24V DC Nominal, 18 - 28V DC Working
<b>Max Coil Inrush Current:</b>	<b>B:</b> 500mA Max to coil <b>C:</b> 250mA Max to coil
<b>Size:</b>	Reference Dimensions on Page 2
<b>Mounting:</b>	M5
<b>Mounting Bolt Torque:</b>	3 - 4 Nm (26-35 in-lb)
<b>Contact Torque:</b>	5 - 6 Nm (45- 53 in-lb)
<b>Terminals:</b>	M6 Silver Plated Copper
<b>Approvals:</b>	UL File No. E510407 Recognized

## Description

High current and high voltage DC contactor relays for electric vehicle, hybrid electric vehicle, renewable storage energy, battery charging and fuel battery, solar energy battery, and general industrial equipment. Utilizes polarized contacts for optimum performance amidst polarized electrical loads.

## Applications

- Battery Electric Vehicles
- Hybrid Electric Vehicles
- Material Handling
- Electric Maintenance and Transport Vehicles
- Industrial Applications

## Features and Benefits

- High current (150A) and high voltage (450V) contactor for EV applications
- Compact structure, helping reduce noise when turned on
- Sealed IP54, gas-filled relay which mitigates arcing
- No mounting orientation restrictions
- Highly reliable contact system with stable contact resistance in harsh environments
- Designed and manufactured under the IATF16949 certification for Automotive Quality Systems.
- Designed specifically for automotive applications.

## Web Resources

Download 2D print and technical resources at:  
[littelfuse.com/DCNEVT150](http://littelfuse.com/DCNEVT150)

## Ordering Information

PART NUMBER	DESCRIPTION	COIL VOLTAGE 12V DC	COIL VOLTAGE 24V DC	BOTTOM MOUNT	SIDE MOUNT
DCNEVT150-BS	High Voltage DC Contactor Relay Side Mount with Polar Load Terminals	•			•
DCNEVT150-B	High Voltage DC Contactor Relay Bottom Mount with Polar Load Terminals	•		•	
DCNEVT150-CS	High Voltage DC Contactor Relay Side Mount with Polar Load Terminals		•		•
DCNEVT150-C	High Voltage DC Contactor Relay Bottom Mount with Polar Load Terminals		•	•	

\* Box Packaging Available

# DCNEVT150 SERIES HIGH CURRENT HIGH VOLTAGE DC CONTACTOR

## Estimated Make Break Chart

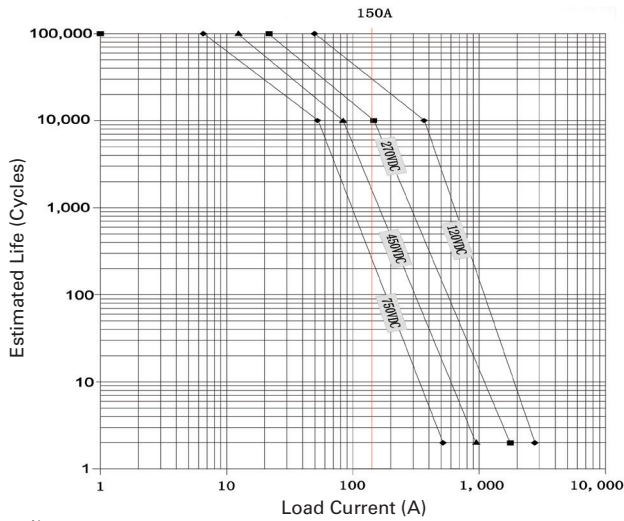

Note:  
Estimates based on extrapolated data.  
User is encouraged to confirm performance in application.

## Bottom Mount Dimensions in MM

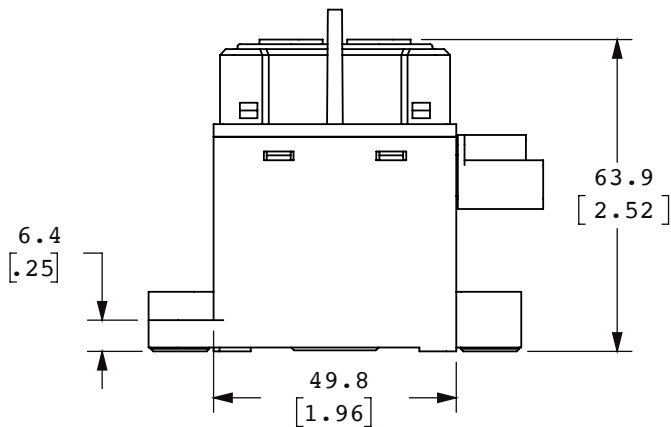
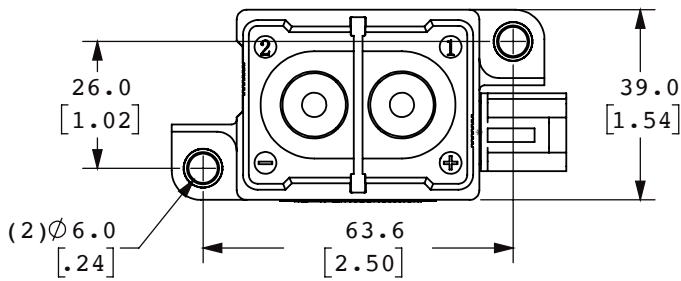

## Electrical Diagram

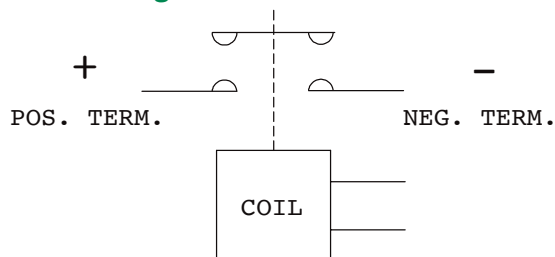

## Electrical Load Life Ratings for Typical EV Applications

MAKE/BREAK LIFE CAPACITIVE & RESISTIVE LOADS AT 320VDC<sup>1,2</sup>

@90% pre-charge (make only), see chart below	30,000 cycles
@Min 80% pre-charge (make only), see chart below	50 cycles

1: Resistive load includes L=25uH. Load @2500A, test @200uH  
2: Life based on projected Weibull Life with 95% reliability.

## Capacitive Make Test Curve

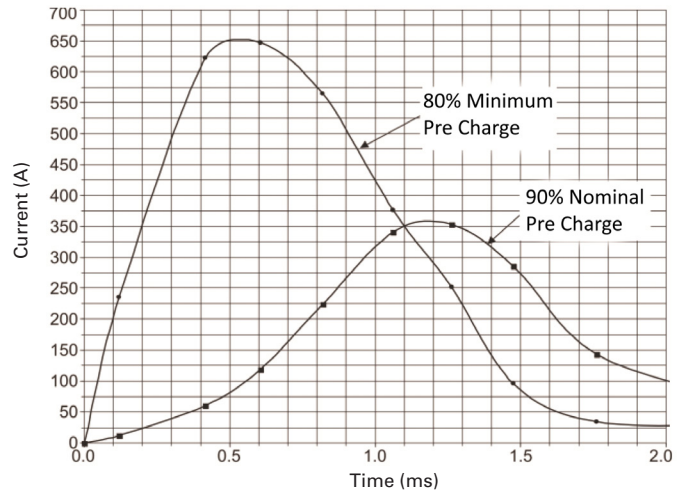

## Side Mount Dimensions in MM

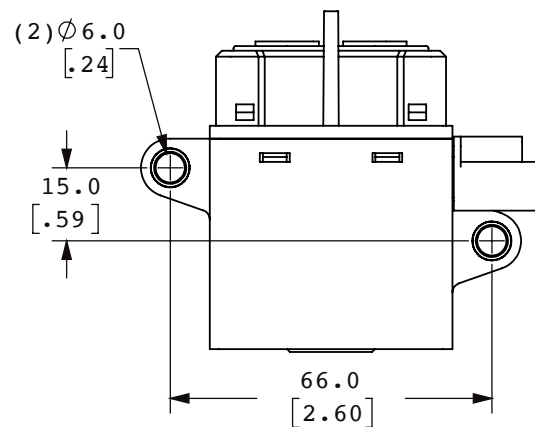
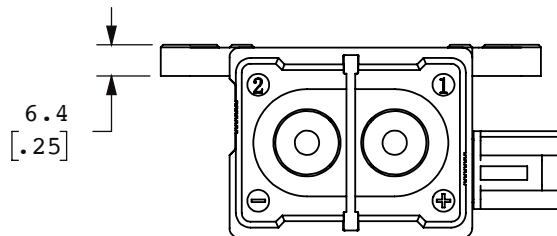

# DCNEVT150 SERIES HIGH CURRENT HIGH VOLTAGE DC CONTACTOR

## Performance Data

MAIN CONTACT	
Contact arrangement	1 Form X (SPST-NO, DM)
Rated Operating Voltage	450VDC
Continuous (Carry) Current	150A (65°C)
Short term	225A (10min, 50mm <sup>2</sup> wire) 320A (2min, 50mm <sup>2</sup> wire)
Max short circuit current	1500A @450VDC, 1 cycle *1
Dielectric Withstanding Voltage	Between Contacts: 3000VDC, ≤1mA Contact to Coil: 2,200Vrms, ≤1mA
Insulation Resistance	Terminal to Terminal/Terminal to coil ≥100 MΩ@500Vdc
Voltage Drop (@100A)	≤100mV

1: Does not meet dielectric & IR after test.

COIL DATA		
Rated Operating Voltage	12Vdc	24Vdc
Max Voltage	15Vdc	28Vdc
Pickup voltage (Max.)	9Vdc	18Vdc
Dropout voltage (Min.)	1.2Vdc	2.4Vdc
Coil power	6W	6W
Inrush Current (Max.)	500mA	250mA

LIFE	
Electrical Life	See estimated make break chart
Mechanical life	200,000 cycles

OPERATE / RELEASE TIME	
Close (includes bounce)	30ms, Max. Bounce 5ms Max.
Release	10ms, Max.

MAX. BREAKING LIMIT	MAX. SHORT CIRCUIT
2,000A @ 320VDC, 1 cycle	2,500A, 1sec

ENVIRONMENTAL DATA	
Shock, 11ms ½ sine, operating	20G Peak
Vibration, Sine, Peak, 5G	10—2,000Hz
Operating Ambient Temperature	-40 to +85°C
Altitude	<4000m
Weight	0.73 lb (0.33kg)

## Current vs Time Curve

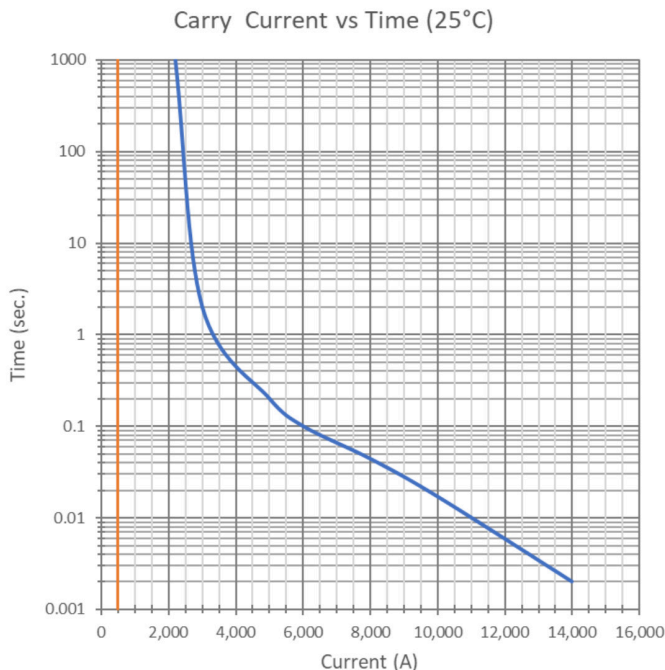

Copper Conductor: 125mm<sup>2</sup>

## Application Note:

1. Be sure to use washer to prevent screws from loosening, all the terminals or copper bar must be in direct contact with the contactor's terminals. Screw tightening torque is specified below. Exceeding the maximum torque can lead to product failure.
  - Contact torque (M6): 45 - 53 lb.in (5 - 6 N.m) Max. Active length of thread is 7.0 mm
  - Mounting torque: 26 - 35 lb.in (3 - 4 N.m)
2. Contact terminals are polarized so refer to drawing during connecting. We suggest using a varistor rather than diode as a surge protector.
3. Do not use if dropped.
4. Avoid installing in a strong magnetic field (close to a transformer or magnet), or near a heat source.
5. Electrical life  
Use per load capability and life cycle limits so as not to cause a function failure (treat the contactor as a product with specified life and replace it when necessary). It is possible to make parts burn around the contactor once operating failure occurs. It is necessary to take layout into account and to make sure power shall be cut off within 1 second.
6. Lifetime of internal gas diffusion  
The contactor is sealed and filled with gas, lifetime of gas diffusion is determined by temperature in contact chamber (ambient temperature + temperature generated by contact operation). Operate only in an ambient temperature from -40 to +85 °C.
7. Avoid debris or oil contamination on the main terminals to optimize contact and avoid excess heat generation.