

REVISION		DESCRIPTION
REV	DATE	
A	6/12/2011	SUSPENSION RELEASE PER SALES RELEASE 07/21/11 HWY

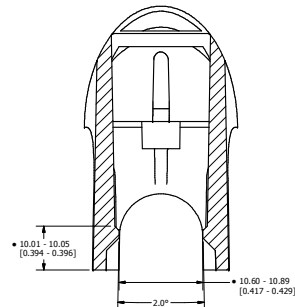

SECTION A-A  
SCALE 3 : 1

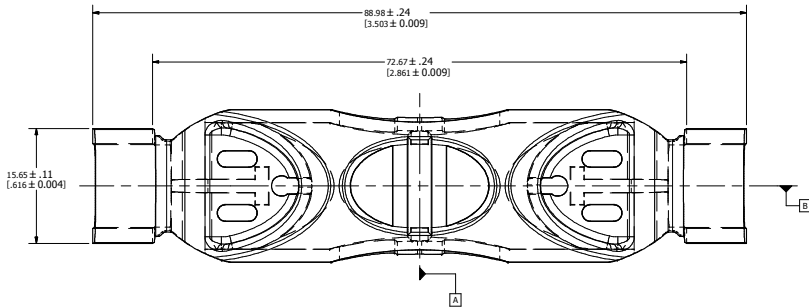
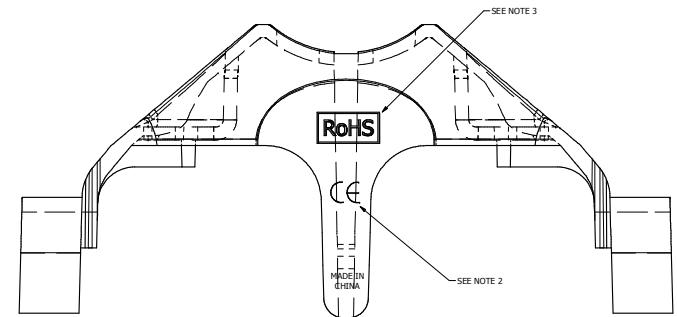
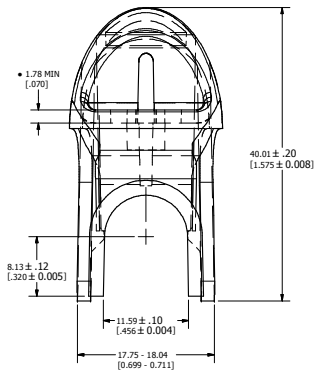
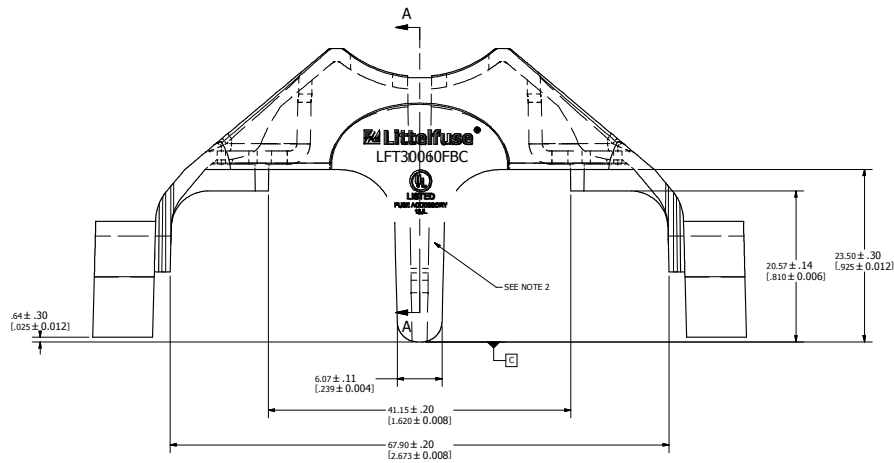
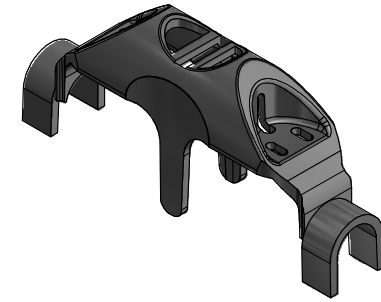

- GENERAL NOTES:**
1. BODY PRINT PRODUCT INFORMATION IN PEG 1002 WHITE INK IN AREAS INDICATED
  2. LOGO INFORMATION TO CONFORM TO LITTELFUSE PRINT 095115
  3. RoHS EMBLEM TO CONFORM TO LITTELFUSE PRINT LS-000003
  4. PRINTING TO BE CLEAR, LEGIBLE, AND NOT SMUDGED
  5. INDIVIDUAL PACKAGING BOX MUST BE OF THE APPROPRIATE SIZE CORRESPONDING TO PART DIMENSIONS
  6. APPLY BOX LABELS TO THE SIDES OF THE PACKAGING BOX IN THE AREAS INDICATED (SEE LS-000085)

- NOTES:**
1. TOOLING TO BE BUILT PER MATH DATA PROVIDED BY LITTELFUSE. GEOMETRY PER MATH TO BE WITHIN  $\pm 0.25A|B|C$  UNLESS OTHERWISE SPECIFIED. DIMENSIONS SHOWN FOR INSPECTION PURPOSES ONLY.
  2. DRAFT ANGLES TO BE PER LITTELFUSE MATH DATA, UNLESS OTHERWISE SPECIFIED.
  3. PARTING LINES, KNOCKOUT PINS AND GATE LOCATION TO BE APPROVED BY LITTELFUSE ENGINEERING PRIOR TO TOOL CONSTRUCTION.
  4. PARTING LINES, KNOCK OUT PINES, AND LIFTER FLASH SHALL BE 0.13 MAX, UNLESS OTHERWISE SPECIFIED.
  5. CORNERS SHOWN SHARP MAY HAVE A 0.25 RADIUS MAX, UNLESS OTHERWISE SPECIFIED BY LITTELFUSE ENGINEERING.
  6. ALL CAVITIES SHALL BE IDENTIFIED. CHECK WITH LITTELFUSE ENGINEERING FOR PREFERRED LOCATION.
  7. PARTS TO BE CLEAN AND FREE OF CRACKS, FOREIGN MATTER, CHIPS, WELD OR FLOW LINES, SINK, DISCOLORATION, PIN HOLES, VOIDS, ROUGHNESS OR WARPAGE UNLESS ACCEPTED BY LITTELFUSE ENGINEERING.
  8. DIMENSIONS TO BE MEASURED AT LOCATION OF MAXIMUM DRAFT, UNLESS OTHER SPECIFIED BY LITTELFUSE ENGINEERING.
  9. PACKAGING CARTON CONTAINING THIS PART TO BE MARKED WITH PART NUMBER AND CURRENT REVISION.
  10. THE  $\Delta$  SYMBOL INDICATES THE DIMENSION NUMBER FOR INSPECTION PURPOSES.
  11. MAXIMUM REGROUND ALLOWED: 25%

DENOTES CRITICAL CHARACTERISTICS.			
●	DENOTES CRITICAL CHARACTERISTICS.		
CPK	DENOTES CPK DIMENSIONS, MINIMUM CPK VALUE UNLESS OTHERWISE SPECIFIED. DIMENSIONS SHOWN FOR INSPECTION PURPOSES ONLY.		
Ⓢ	DENOTES CHARACTERISTICS THAT PROVIDES AN INDICATION OF PROCESS PERFORMANCE. PROCEDURE FOR MEASUREMENT AND TRACKING TO BE SPECIFIED BY LITTELFUSE INSPECTION INSTRUCTIONS.		
CP	DENOTES CP DIMENSIONS, MINIMUM CP VALUE MUST BE WITHIN THE DIMENSIONAL LIMITATIONS SHOWN ON DRAWING AND INITIALLY LOCKED TO ALLOW FOR MAXIMUM TOOL LIFE.		
MATL SPEC	AVIETTE FR 530	FINISH	SCALE: BLACK
COMP	DATE: 12/12/11	SCALE	FRESH GOOD WT
IMP		HTS	CONFORMS TO
UNLESS OTHERWISE SPECIFIED, DIMENSIONS ARE IN MILLIMETERS, DIMENSIONS IN BRACKETS ( ) ARE INCHES DIMENSIONING AND DO NOT INCLUDE PLATING. TOLERANCING TO BE INTERPRETED IN ACCORDANCE WITH ANSI Y14.5M-1994.			
3D MODEL PROJECTION	TOLERANCE UNLESS OTHERWISE SPECIFIED		
	ONE PLACE DEC ± .35 (0.1)	FRACTION ±	
	TWO PLACE DEC ± .10 (0.01)	ANGLE ±	1.1°
TITLE: 300V CLASS T 60A FUSEBLOCK COVER			
Littelfuse DES PLAINES, ILLINOIS 60546		REVISION	DRAWING NO.
		A	LFT30060FBC
			SHEET 1 OF 1