

| REVISION | | |
|----------|---------|-------------------------|
| REV | DATE | DESCRIPTION |
| A | 7/19/23 | 526717GCP - RELEASE MRY |

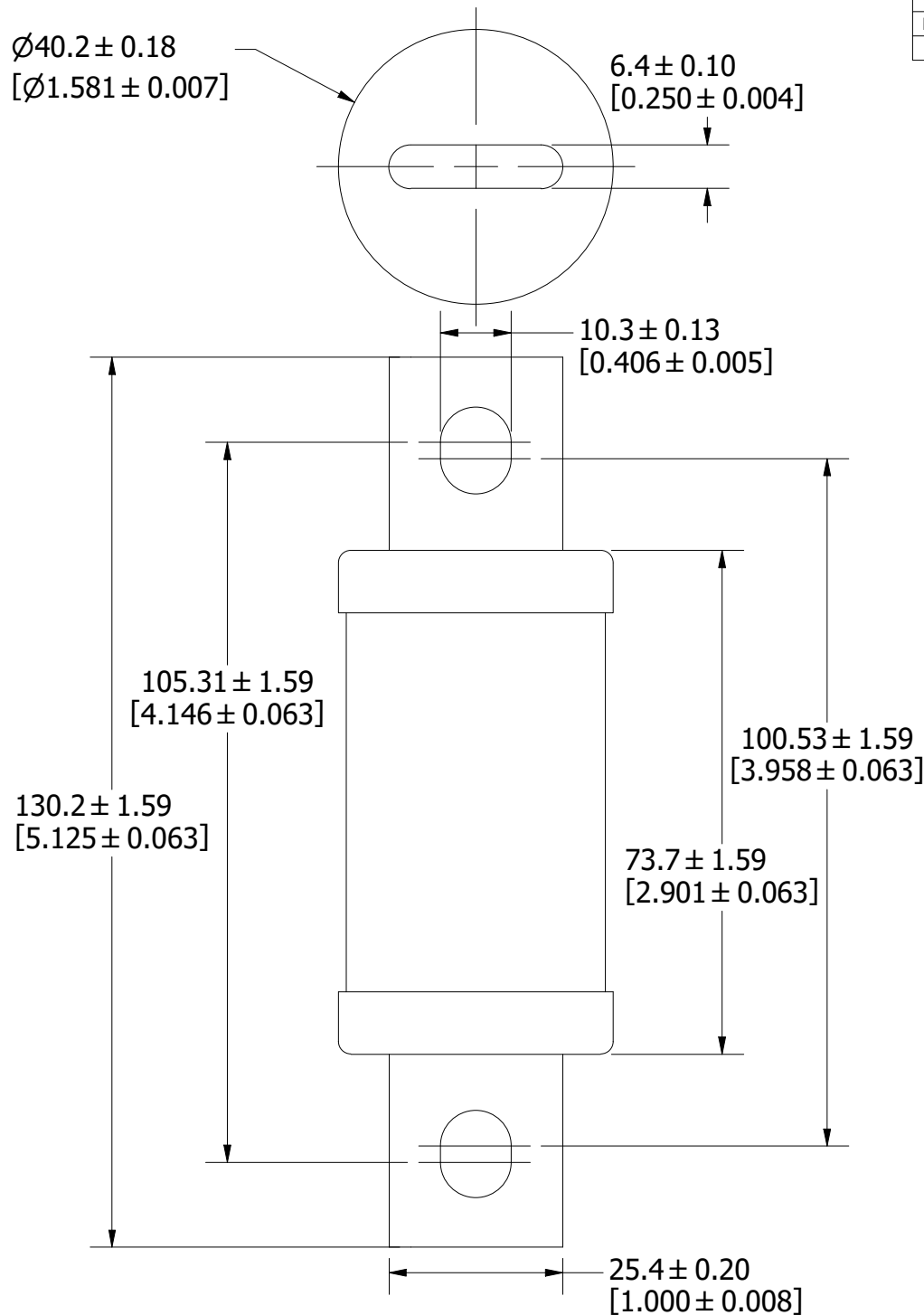

| 1 | COMPONENT NO | DESCRIPTION | QTY/M | U/M | |
|---|--|----------------------|-------------------------------|--------------|--|
| BILL OF MATERIAL | | | | | |
| <S> | CRITICAL CHARACTERISTIC FOR PART SAFETY/COMPLIANCE | | | | |
| ● | DENOTES CRITICAL CHARACTERISTICS. | | | | |
| CPK | DENOTES CPK DIMENSIONS, -MINIMUM CPK VALUE | | | | |
| ST | DENOTES A CHARACTERISTIC THAT PROVIDES AN INDICATION OF PROCESS PERFORMANCE. PROCEDURE FOR MEASUREMENT AND TRACKING TO BE DEFINED IN LITTELFUSE INSPECTION INSTRUCTIONS. | | | | |
| CP | DENOTES CP DIMENSIONS, -MINIMUM CP VALUE MUST BE WITHIN THE DIMENSIONAL LIMITATIONS SHOWN ON DRAWING AND INITIALLY LOCATED TO ALLOW FOR MAXIMUM TOOL LIFE. | | | | |
| MATL SPEC | | | FINISH | | |
| DRW JMoler | DATE 6/23/2023 | SCALE NTS | FINISH GOOD WT GRAMS/PIECE | | |
| UNLESS OTHERWISE SPECIFIED, DIMENSIONS ARE IN MILLIMETERS, DIMENSIONS IN BRACKETS [] ARE INCHES DIMENSIONING AND DO NOT INCLUDE PLATING. TOLERANCING TO BE INTERPRETED IN ACCORDANCE WITH ANSI Y14.5M-1994 | | | | | |
| 3RD ANGLE PROJECTION | | | | | |
| TITLE L60S 225-400A OUTLINE | | | | | |
| CHICAGO, ILLINOIS 60631 | | REVISION A | DRWG NO. OL-L60S400 | SHEET 1 OF 1 | |

A