



MODEL ALT-XXX-3-SW



II-ALT-XXX-3-SW-B



DANGER!



HAZARDOUS VOLTAGES MAY BE PRESENT DURING INSTALLATION.

Electrical shock can cause death or serious injury.

Installation should be done by qualified personnel following all national, state and local electrical codes.



**BE SURE POWER IS DISCONNECTED PRIOR TO INSTALLATION!
FOLLOW NATIONAL, STATE AND LOCAL CODES.
READ THESE INSTRUCTIONS ENTIRELY BEFORE INSTALLATION.**

SymCom's PumpSaver[®] Model ALT-XXX-3-SW is designed to alternate between two loads. It is commonly used in duplex pumping applications to balance the run time of two pumps (loads). The loads may run one at a time or simultaneously. The voltage designation must be specified in the part number.

The Model ALT-XXX-3-SW uses three inputs (1 Lead, 1 Lag and 1 Stop) and has two outputs for controlling operation of the two loads. The inputs to the PumpSaver[®] are usually floats that close or open depending on fluid level. The Lead and Lag float switch inputs actuate latching relays and the Stop float switch input unlatches both relays. The user has the option to force one load to run exclusively at all times when the other load has been removed for maintenance or repair.

The Model ALT-XXX-3-SW activates Load 1, Load 2, or both, based on the current adjustment knob position and the previous action. Example: In the AUTO setting, if Load 1 activated as the lead pump previously, Load 2 will be the lead pump in the current cycle.

CONNECTIONS

1. The ALT-XXX-3-SW requires an 8-pin socket, part number OT08 (sold separately).
2. Mount the PumpSaver[®] socket in a convenient location in or near the pump control panel. If the location is wet or dusty, it should be mounted in a NEMA 4 or 12 enclosure.

NOTE: See Figure 3 for a typical wiring diagram showing the following connections.

3. Connect one pump's magnetic contactor coils (M1) between socket terminal 8 and L2 of the power supply
4. Connect the other pump's magnetic contactor coil (M2) between socket terminal 7 and L2 of the power supply
5. Connect the power supply L1 to socket terminal 3 and power supply L2 to socket terminal 6.
6. Connect lead switch device between socket terminal 1 and L1.
7. Connect lag switch device between socket terminal 2 and L1.
8. Connect stop switch device between socket terminal 4 and L1.
9. Plug the Model ALT-XXX-3-SW into the socket.

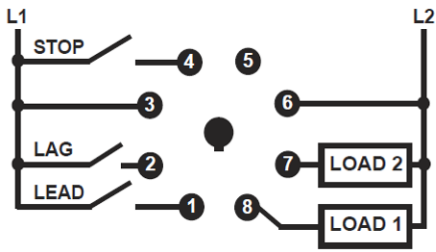

Figure 1: Pin-Out Diagram

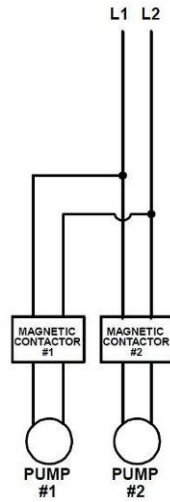

Figure 2: Connections for Input Power, Magnetic Contactors, and Pumps

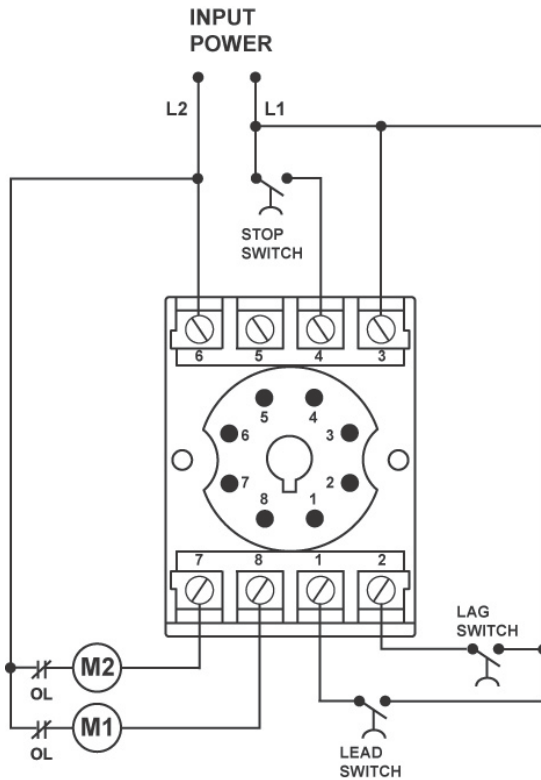

Figure 3: Typical Wiring Diagram

SETTINGS

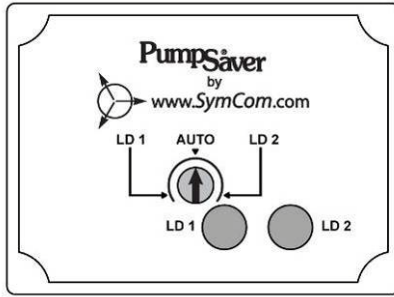

Figure 4: User-Selectable Options

To let the unit automatically select the load to be activated next, set the dial to "AUTO". Turn the adjustment knob to the selected load to allow only that specific load to be activated. This de-activates the other load if it is currently activated. This allows one pump to be taken out of the circuit for repair or replacement. See Figure 4.

! DANGER!



Lock-out power to the ALT-XXX-3-SW before attempting to repair or replace wiring or loads.



OPERATION

The ALT-XXX-3-SW has built-in fail-safe technology that prevents many float malfunctions from causing a tank to overflow.

The operation of the outputs is governed by the following rules:

1. If all three float switches are open, no loads are activated.
2. If the Lead switch is closed, regardless of the Stop switch position, at least one load will be activated.
3. If the Lag switch is closed, regardless of the Lead switch position, both loads* will be activated.
4. If the pot is turned to force one of the loads, then only the selected load* may be activated.

***NOTE:** If the Stop switch fails to close, Load 2 will be unable to activate.

Apply power to the system. Indicator lights will show which loads, if any, are currently active.

Table 1 describes which load(s) is active according to the current and previous status of the switches.

CYCLE	SWITCH/SENSOR EVENT	LOAD 1	LOAD 2
1	None (just starting up)	OFF	OFF
1	Stop Switch Closes	OFF	OFF
1	Lead Switch (1) Closed/Activated from OFF state	ON	OFF
1	Lead Switch (1) Closed and Lag Switch (2) Closed from OFF state	ON	ON
1	Lag Switch Opens; Lead Switch Opens	ON	ON
1	Stop Switch Opens	OFF	OFF
2	Stop Switch Closes	OFF	OFF
2	Lead Switch (1) Closed/Activated from OFF state	OFF	ON
2	Lead Switch (1) Closed and Lag Switch (2) Closed from OFF state	ON	ON
2	Lag Switch Opens; Lead Switch Opens	ON	ON
2	Stop Switch Opens	OFF	OFF

Table 1: Inputs and On/Off States During Normal Float Operation

INDICATOR LIGHTS	STATUS
LD1 ON	LOAD 1 ACTIVE
LD2 ON	LOAD 2 ACTIVE
LD1 AND LD2 ON	LOAD 1 AND LOAD 2 ACTIVE
NO LIGHTS	NO LOAD ACTIVE
LIGHTS ALTERNATING	OUT-OF-SEQUENCE ALARM

Table 2: Diagnostic Indicator Lights

TROUBLESHOOTING

SYMPTOM	LIGHT PATTERN	SOLUTION
Device is not functioning properly	N/A	No lights will be on during normal operating conditions if no switches are closed. Verify float switches are functioning properly and all connections are good. Measure the input voltage. If the voltage is below the minimum listed in the Specification Table, the PumpSaver® alternating relay does not have enough power to operate its internal electronics. If the voltages are correct, call SymCom at (800) 843-8848 or (605) 348-5580.
OUT-OF-SEQUENCE ALARM	LIGHTS ALTERNATING	The ALT-XXX-3-SW has detected one of the switches has opened or closed out of the proper sequence. Check for the following conditions that may be causing the alarm: 1.) Stop switch stuck open 2.) Lead switch stuck open or closed 3.) Lag switch stuck closed

DIMENSIONS

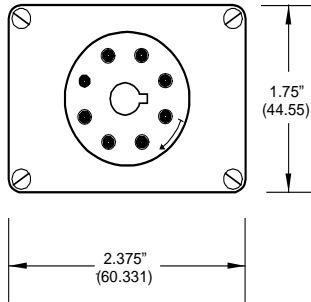

BOTTOM

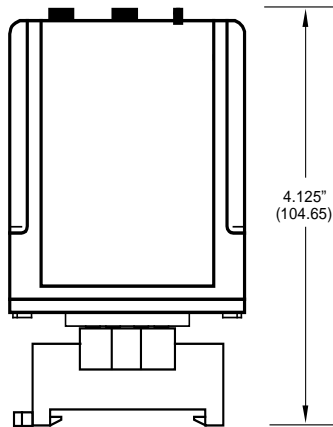

**SIDE
WITH OT08* SOCKET**

*Use of the OT08-PC or RB08-PC octal socket, manufactured by Custom Connector Corp., is required for the MotorSaver to qualify as a UL Listed device. The OT08-PC is 35mm DIN rail compatible.

PUMPSAVER® ALT-XXX-3-SW SPECIFICATIONS

Functional Characteristics	
Debounce Time Delay	5 seconds
Input Characteristics	
Line Supply Voltage ALT-100-3-SW ALT-200-3-SW Frequency	95-120VAC 190-240VAC 50/60Hz
Output Characteristics	
Output Contact Rating Pilot Duty General Purpose	480VA @ 240VAC 10A @ 240VAC
General Characteristics	
Environmental Ambient Operating Temperature ¹ Relative Humidity Maximum Input Power Standards Passed Electrostatic Discharge (ESD) Radio Frequency Immunity, Radiated Fast Transient Burst Surge Immunity IEC ANSI/IEEE Hi-Potential Test Safety Marks UL listed (OT08 octal socket required) CE Dimensions Weight Enclosure Mounting Method Wire Gauge Terminal Torque for P/N OT08 Socket	-40° to 70°C (-40° to 158°F) 10-95%, non-condensing per IEC 68-2-3 5 W IEC 61000-4-2, Level 3, 6kV contact, 8kV air 150 MHz, 10V/m IEC 61000-4-4, Level 3, 3.5kV input power and controls IEC 61000-4-5, Level 3, 4kV line-to-line; Level 4, 4kV line-to-ground C62.41 Surge and Ring Wave Compliance to a level of 6kV line-to-line Meets UL508 (2 x rated V +1000 V for 1 minute) UL508 (File #E68520) IEC 60947-6-2 1.750" H x 2.375" W x 4.125" D (with socket) 9 oz. Polycarbonate Plugs into OT08 Socket; can be mounted to DIN rail or surface mount 12-22 AWG Solid or Stranded 12 in. – lb

¹ The ambient air temperature is the air temperature directly surrounding the product.

For warranty information, please see **Terms and Conditions** at
www.symcom.com

*Visit us at www.symcom.com to see
our complete product listing!*

Need something special?

*Contact SymCom today
for your custom solution!
800-843-8848*