

INSTALLATION INSTRUCTIONS FOR SYMCOM'S MODEL 601 VOLTAGE MONITOR RELAY

**BE SURE POWER IS DISCONNECTED PRIOR TO INSTALLATION!!
FOLLOW NATIONAL, STATE AND LOCAL CODES!
READ THESE INSTRUCTIONS ENTIRELY BEFORE INSTALLATION.**

DANGER!

HAZARDOUS VOLTAGES MAY BE PRESENT DURING INSTALLATION.

Electrical shock can cause death or serious injury.

Installation should be done by qualified personnel following all national, state and local electrical codes.



CONNECTIONS

1. Using the four corner tabs OR the DIN rail mounting bracket, mount the Model 601 securely in the panel. To use the DIN rail bracket, hook the top clip first, then apply downward pressure until the lower clip "clicks" onto the rail, then stop applying downward pressure.
2. Connect the three-phase power from the line side of the contactor to "L1", "L2" and "L3". First carefully strip and insert a #12 - #18 AWG wire into the top of the terminal marked L1 and tighten the screw on the front of the relay. Then, connect the other end of the wire to the line side of the contactor. Repeat these two steps for L2 and L3. (see Figure No. 1).
3. Connect the output relay to the circuitry to be controlled (see Figure No. 1). To control a motor, connect the normally open contact in series with the magnetic coil of the motor starter as shown. To sound an alarm, connect the normally closed contact in series with the alarm.

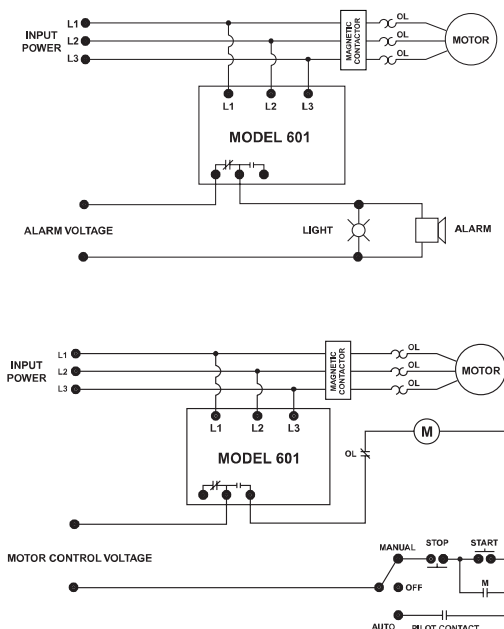

Figure No. 1: Typical Wiring Diagrams



www.SymCom.com

... your electronic control & protection specialists

222 Disk Drive, Rapid City, SD 57701

(800) 843-8848 www.symcom.com

PROGRAMMING

1. Select the feature to program by rotating the "MODE SELECT" switch to the desired position.
2. Push and hold the "RESET / PROGRAM" button.
3. Rotate the "DISPLAY / PROGRAM" adjustment to the desired setting of the feature as shown in the LED display.
4. Release the "RESET / PROGRAM" button. The Model 601 is programmed when the button is released.
5. Continue steps 1-4 until all features are programmed.

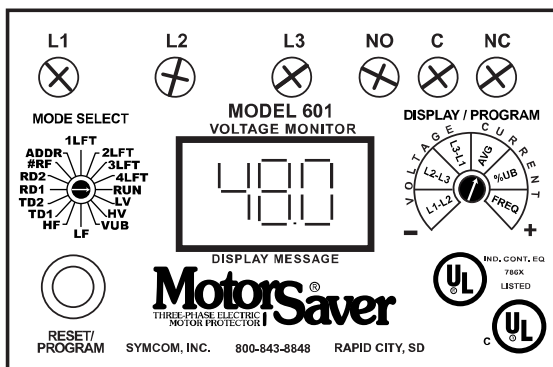

SUGGESTED SETTINGS (Consult the Motor Manufacturer for their recommendations.)

LV/HV- The recommended settings for "LV" (low voltage) and "HV" (high voltage) depend on many factors such as motor usage, motor size, environmental factors and tolerance of the motor. The motor manufacturer should be consulted for "HV" and "LV" settings. However, the NEMA MG1 standard recommends that "LV" and "HV" be set to no more than $\pm 10\%$ of the motor's nameplate voltage. The setting can be determined by multiplying the motor's nameplate voltage by the recommended percent over and under voltage. (eg., The motor nameplate voltage is 230 V, set "LV" to $0.9 \times 230 = 207$, set "HV" to $1.10 \times 230 = 253$) "LV" can not be set higher than "HV", so "HV" may have to be adjusted higher before the proper "LV" setting can be programmed.

VUB- "VUB" is the voltage unbalance trip point. The NEMA MG1 standard does not recommend operating a motor above a 1% voltage unbalance without derating the motor. Voltage unbalance is determined from the following formula:

$$\% \text{ Voltage Unbalance} = [(\text{Maximum Deviation from the Average}) / \text{Average}] \times 100\%$$

The NEMA MG1 standard also recommends against operating a motor above a 5% voltage unbalance under any circumstances. Therefore, a setting of "5" is a good place to start but SymCom recommends consulting the motor manufacturer for specific tolerances.

Note: A setting of "999" in this position will eliminate voltage unbalance protection. Single phase protection is still active for unbalances in excess of 15%.

LF- "LF" setting is the Low Frequency Trip threshold. The NEMA MG1 standard recommends against operating a motor on a supply with more than $\pm 5\%$ variation in frequency. On a 60Hz system, $60 \times .95 = 57\text{Hz}$.

- HF-** "HF" setting is the High Frequency Trip threshold. Using the NEMA MG1 standard on a 60Hz system, "HF" = $60 \times 1.05 = 63\text{Hz}$.
- TD1-** "TD1" is the Trip Delay time for voltage and frequency faults. This includes voltage unbalance, low voltage, high voltage, low frequency and high frequency. A setting of 5-10 seconds is normally a good place to start for these types of faults.
- TD2-** "TD2" is the Trip Delay time for single-phasing faults. A setting of 2-4 seconds is a good place to start.
- RD1-** "RD1" is the rapid cycle timer. It will engage when the MotorSaver is first powered-up. An "RD1" setting of 20-30 seconds will generally protect the motor from rapid, successive power outages. A setting of 0 seconds will allow the motor to start immediately after power-up.
- RD2-** "RD2" is the restart delay after a fault occurs. This delay allows the motor to cool down after experiencing a fault. It is also known as a motor cool down timer. Your motor manufacturer should be contacted to determine this setting. Under normal circumstances, a setting of 300 seconds will give the motor enough time to cool down between faults.
- #RF-** "#RF" is the type of reset after a fault. A setting of "0" is manual reset and a setting of "A" is continuously automatic.
- ADDR-** "ADDR" is the address setting for RS485 communications. Available settings are from A01 - A99. You may ignore this setting if RS485 communications are not used.
- 1LFT, 2LFT, 3LFT, 4LFT-** These positions are the last four faults stored in memory. **Note:** The motor will be shut down when accessing these positions. Also, the last fault may be displayed by pushing the "RESET" button at any time during normal operation.

MULTI-FUNCTION SYSTEM DISPLAY

The output display can show various system operating parameters:

- L1-L2 Voltage
- Average Voltage
- L2-L3 Voltage
- % Voltage Unbalance
- L3-L1 Voltage
- Line Frequency

When the "MODE SELECT" switch is in the "RUN" position, the LED will display one of the above operating parameters. To select or change the displayed parameter, turn the "DISPLAY / PROGRAM" adjustment to the desired position as shown on its label.

The multifunction display also announces system faults such as low voltage, high voltage, single phasing, voltage unbalance, and reverse phasing errors. Any time the "MODE SELECT" switch is in the "RUN" position, the "RESET/PROGRAM" button may be pushed to view the last fault which occurred. The table on page 4 shows the possible messages. To view the previous faults, rotate the "MODE SELECT" switch to the corresponding last fault. **NOTE:** Rotating the "MODE SELECT" switch out of the run position will de-energize the Model 601's contacts and shut down the motor.

Displayed Message	Meaning
oc	Tripped on Overcurrent
SP	Tripped on Single Phasing
ub	Tripped on Voltage or Current Unbalance
uc	Tripped on Undercurrent
CF	Tripped on Contactor Failure (3ØVoltage Input Only)
GrF	Tripped on Ground Fault
H I	Tripped on High Voltage
Lo	Tripped on Low Voltage
rP	Incoming phases have been reversed. Your motor may run backward if started. (3Ø Voltage Input Only)
oFF	A stop command was issued from a remote source.

COMMUNICATIONS PORT / REMOTE RESET

The Model 601 comes standard with a 9-pin sub-D connector for remote communications. The Model 601 supports RS-485 communication standard. This standard allows up to 99 Model 601s to be controlled and monitored from a single remote personal computer. NOTE: An RS-485MS-2W module and software is required to operate the communications bus. (Refer to RS-485MS-2W Installation Instructions for more information on this subject.) The communications port also provides connections for remote reset as shown on the right.

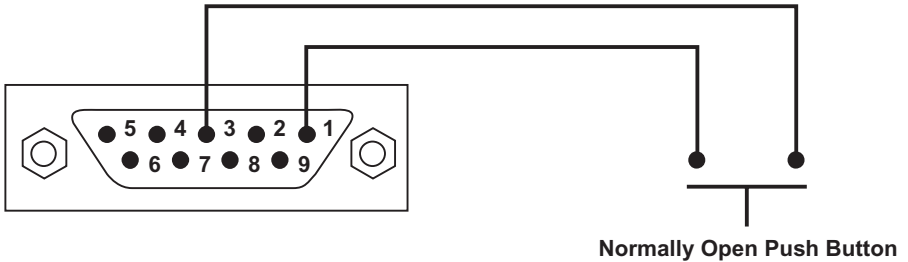

OPERATION

Once the relay has been programmed, turn the "MODE SELECT" switch to the "RUN" position. The LED display will flash "RUN" alternately with a number representing the parameter indicated by the "DISPLAY / PROGRAM" adjustment. After the period of time programmed into RD1, the output contacts will close and the value of the parameter indicated by the "DISPLAY / PROGRAM" adjustment will appear on the LED display.

If a message other than those indicated above is shown on the LED display, see the TROUBLESHOOTING section to diagnose the problem.

If you need further assistance, call us at [1-800-843-8848](tel:1-800-843-8848)...we'd be happy to help!!

TROUBLESHOOTING	
PROBLEM	SOLUTION
The unit will not start. Display alternates "rP" with the "DISPLAY / PROGRAM" switch parameter value.	The voltage inputs are reverse phased. If this is the initial start up, swap any two of the leads connected to "L1", "L2", or "L3" to correct the problem. If the relay has been previously running, the power system has been reverse phased. Check the phase sequence of the incoming power lines.
The unit will not start. Display alternates "SP", "uB", "HI", "Lo", "HF" or "LF" with the "DISPLAY / PROGRAM" switch parameter value.	The incoming voltage is not within the limits programmed in the "VUB", "HV", "LV", "HF" and "LF" settings. Adjust the "DISPLAY / PROGRAM" switch to read the incoming line voltage values. Correct the incoming power problem and check programmed limits to verify they are correct.
Display alternates "SP", "uB", "LF", "HF", "Lo" or "HI" with "RUN."	The relay has tripped on the fault shown on the LED display and is timing down "RD2" before restarting.
Display is showing a solid "SP", "uB", "HI", "Lo", "LF" or "HF."	The unit has tripped on the fault shown and manual reset is required because of the programmed setting in "#RF".

SPECIFICATIONS	MODEL 601
Input Voltage	200 - 480 VAC, 3Ø (Standard)
	(500-600 VAC, 3Ø Available)
Frequency	50 - 60 Hz
Programmable Operating Points	Range
LV - Low Voltage Threshold	170V (450V*) - HV Setting
HV - High Voltage Threshold	LV Setting - 528V (660V*)
VUB - Voltage Unbalance Threshold	2 - 15% or 999
LF - Low Frequency Threshold	35 Hz - HF Setting
HF - High Frequency Threshold	LF Setting - 75 Hz
TD1 - Trip Delay for Voltage/Unbalance/Frequency Faults	1 - 50 Seconds
TD2 - Trip Delay for Single Phase Faults	1 - 50 Seconds
RD1 - Rapid Cycle Timer	0, 2 - 500 Seconds
RD2 - Restart Delay After All Faults	2 - 500 Seconds
#RF - Type of Restart	"A" Automatic or "0" Manual
ADDR - RS485 Address	A01 - A99
Fixed Hysterisis Reset Points	
Over Voltage Reset	97% of HV Setting
Low Voltage Reset	103% of LV Setting
Voltage Unbalance Reset	UB Setting - 1%
Low Frequency Reset	LF Setting + 0.6Hz
High Frequency Reset	HF Setting - 0.6Hz
Physical Specifications	
Output Contact Rating (Pilot Duty) SPDT	480 VA @ 240 VAC (Standard)
	470 VA @ 600 VAC (Optional**)
Transient Protection (Internal)	2500 V for 10 mSeconds
Accuracy	
Voltage	±1%
Timing	5% ± 1 Second
Repeatability	
Voltage	±0.5%
Temperature Range	0 - 70 °C
Dimensions	3.1" H x 5.1" D x 3.9" W
Power Consumption	5 Watts (Max.)
Weight	1.2 lbs.

NOTES:

SymCom's Model 601 can be preprogrammed prior to installation by applying 120 VAC between the L1 and L2 terminals.

* 575 Volt Model (MS601-575).

** MS601-HVR.

Clearing Last Fault

The last fault stored can be cleared on the MotorSaver.

This procedure is outline as follows:

1. Rotate the Mode Select Switch to 4LFT .
2. Press and hold the Reset/Program Button. Adjust the Display/Program adjustment until cLr appears on the display. Release the Reset/Program Button.

To verify the last fault was cleared, place the Mode Select switch in the Run position. Then press and hold the Reset/Program Button, cLr should be on the display.

Tamper Guard

The PumpSaver can be protected from unauthorized program changes by locking in the setpoints.

This procedure is outlines as follows:

1. Rotate the Mode Select switch to 4LFT .
2. Rotate Display/Program adjustment fully clockwise.
3. Press and hold the Reset Button. Adjust the Display/Program adjustment until Loc appears in the display.
4. Release the Reset Button.
5. Turn Mode Select switch to run .

The program is now locked, but all settings can be viewed. The unit can be unlocked by following the procedure above except step three. This step should say: Press and hold the Reset Button. Adjust the Display/Program adjustment until unL appears in the display.

Model 601 Dimensions

