

# FPS SERIES

## Feeder Protection System



1



2

### Description

The FPS Feeder Protection System monitors voltage and current to provide a comprehensive package of 17 protective functions. The FPS is a modular system with integrated protection, breaker control, metering, and data-logging functions.

#### 1 Operator Interface (FPS-OPI)

- Large, bright, 4 x 20 vacuum-fluorescent display
- Display metered values
- Access set points
- Powered by Control Unit
- Panel mount or attach directly to Control Unit
- Remote mounting (1.2 km or 4000 ft maximum loop length)
- 1/2 DIN size
- Hazardous-location certified

#### 2 Control Unit (FPS-CTU)

- Current inputs—5-A or 1-A secondary phase current transformers
- Voltage inputs—up to 600 V without PTs
- Earth-leakage input—5-A or 1-A secondary or sensitive transformer
- 8 digital inputs, 5 relay outputs, 1 analog input and output
- 24-Vdc supply for OPI and RTD modules, and for digital inputs
- IRIG-B time-code input
- 1/2 DIN size, surface mount
- RS-485 network communications (Standard)
- DeviceNet™, Profibus®, or Ethernet communications available

### Simplified Circuit Diagram

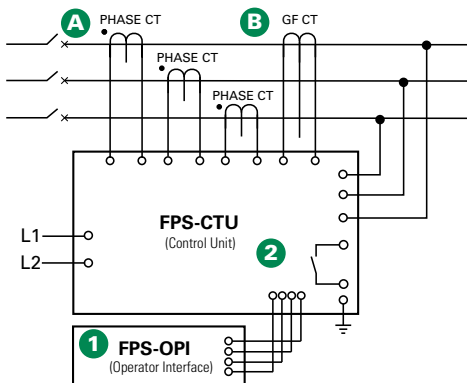

### Ordering Information

ORDERING NUMBER	COMMUNICATIONS
FPS-CTU-01-00	RS-485
FPS-CTU-02-00	RS-485 & DeviceNet™
FPS-CTU-03-00	RS-485 & Profibus®
FPS-CTU-04-00	RS-485 & Ethernet

ACCESSORIES	REQUIREMENT
FPS-OPI-01-00	Recommended
SE-IP65CVR-M	Optional
Phase CTs	Required
Ground-Fault CT	Recommended
MPS-RTD-01-00	Optional

### Accessories

**A Phase Current Transformers**  
Phase CTs are required to detect phase currents.

**B Ground-Fault Current Transformer**  
Zero-sequence current transformer detects ground-fault current. Available with 5-A and 30-A primary ratings for low-level pickup.

**C MPS-RTD Temperature Input Module**  
Optional module provides 8 inputs to connect Pt100, Ni100, Ni120, and Cu10 RTDs.

**D SE-IP65CVR-M Cover**  
Optional gasketed, transparent cover for limited access and IP65 protection for an Operator Interface Module.

# FPS SERIES

## Feeder Protection System

### Features & Benefits

FEATURES	IEEE #	BENEFITS
<b>Overload</b>	49, 51	Long-time overcurrent provides thermal protection for feeder or load
<b>Inverse-time overcurrent</b>	50, 51	Coordination using IEEE and IEC Curves
<b>Definite-time overcurrent</b>	50, 51	Instantaneous overcurrent to detect catastrophic failure
<b>Current unbalance/ Phase loss/Phase reverse</b>	46	Detects an open or high-impedance phase
<b>Ground fault</b>	50G/N, 51G/N	Inverse and definite time. Early insulation-failure detection.
<b>RTD temperature</b>	38, 49	Optional protection (MPS-RTD module) for load-temperature monitoring
<b>Overvoltage</b>	59	Limits stress to insulation
<b>Undervoltage</b>	27	Detects a damaging brown-out condition
<b>Voltage unbalance</b>	47	Detects unhealthy supply voltage
<b>Two setting groups</b>		Minimizes Arc-Flash hazards during maintenance
<b>Breaker control</b>		Allows local and remote operation; reduces component count
<b>Metering</b>		Displays the measured and calculated parameters
<b>Data logging</b>		On-board 64-event recorder helps with system diagnosis
<b>Communications</b>		Remotely view measured values, event records, & reset trips
<b>Conformal coating</b>		Internal circuits are conformally coated to protect against corrosion and moisture

### Wiring Diagram

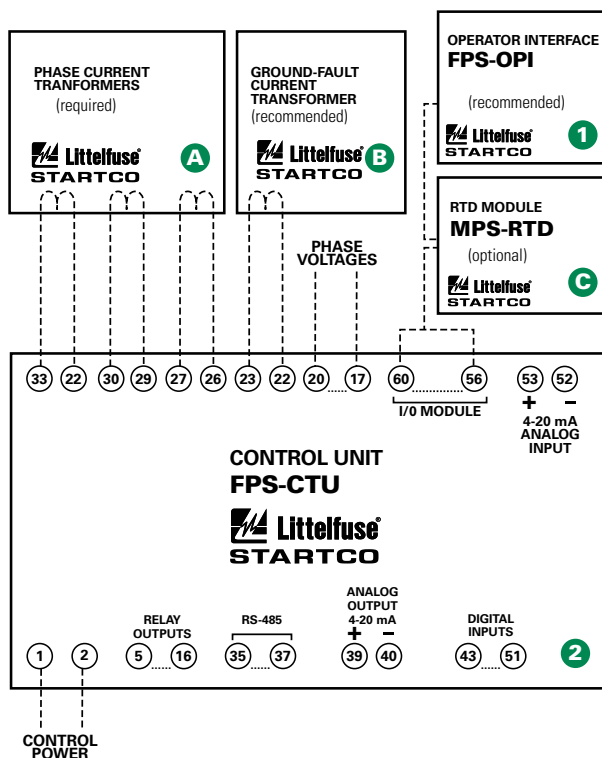

### Specifications

<b>Protective Functions (IEEE Device Numbers)</b>	Overload (49, 51)	Unbalance (current) (46)	
	Phase reverse (current) (46)	Phase loss (voltage) (47)	
	Overfrequency (81)	Overvoltage (59)	
	Overcurrent (50, 51)	Phase loss (current) (46)	
	Underfrequency (81)	Undervoltage (27)	
	Ground fault (50G/N, 51G/N)	Phase reverse (voltage) (47)	
	Unbalance (voltage) (47)	Power factor (55)	
	RTD temperature (38, 49)		
	<b>Input Voltage</b>	65-265 Vac, 25 VA; 80-275 Vdc, 25 W	
	<b>Power-Up Time</b>	800 ms at 120 Vac	
<b>Ride-Through Time</b>	100 ms minimum		
<b>24-Vdc Source</b>	100 mA maximum		
<b>AC Measurements</b>	True RMS and DFT, Peak, 16 samples/cycle, and positive and negative sequence of fundamental		
	50 or 60 Hz		
<b>Frequency Inputs</b>	Phase current, Earth-leakage current, Phase voltage, 7 digital, 1 analog		
	5 contacts — See Product Manual		
<b>Approvals</b>	CSA certified, C-Tick (Australian)		
<b>Communications</b>	Allen-Bradley® DFI and Modbus® RTU (Standard); DeviceNet™, Profibus®, Ethernet (Optional)		
	Standard feature		
<b>Conformal Coating</b>	Standard feature		
<b>Warranty</b>	10 years		
<b>Mounting:</b>	<b>Control Unit</b>	Surface	
	<b>Operator Interface</b>	Panel, Control-Unit mounted	