

MOUNTING SPECS:

RECOMMENDED FASTENER: M10 OR 3/8"  
TIGHTENING TORQUE (REFERENCE ONLY): 26Nm

REVISION		DESCRIPTION
REV	DATE	
A	2/28/24	527536GCP - RELEASE JTM

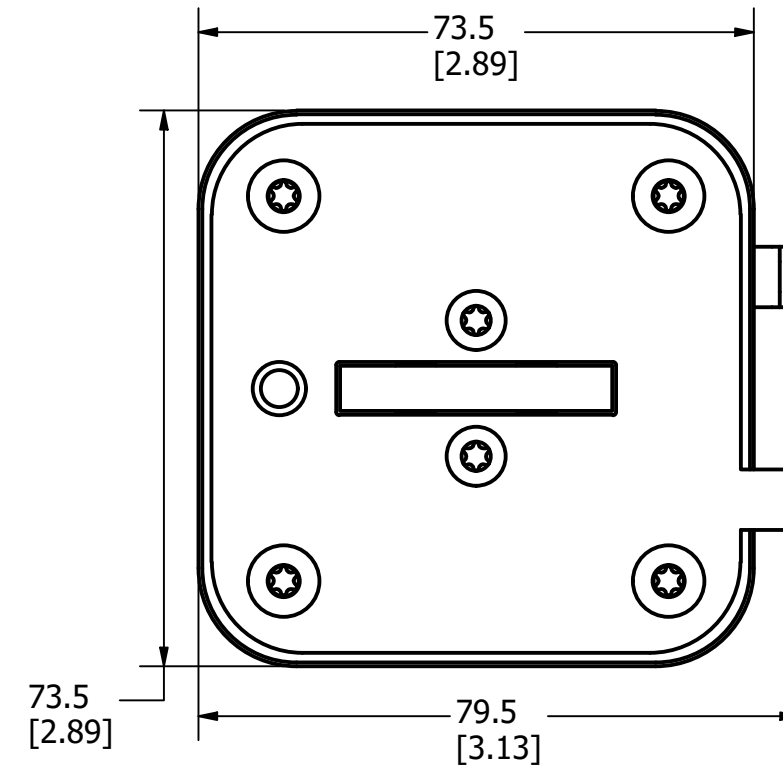
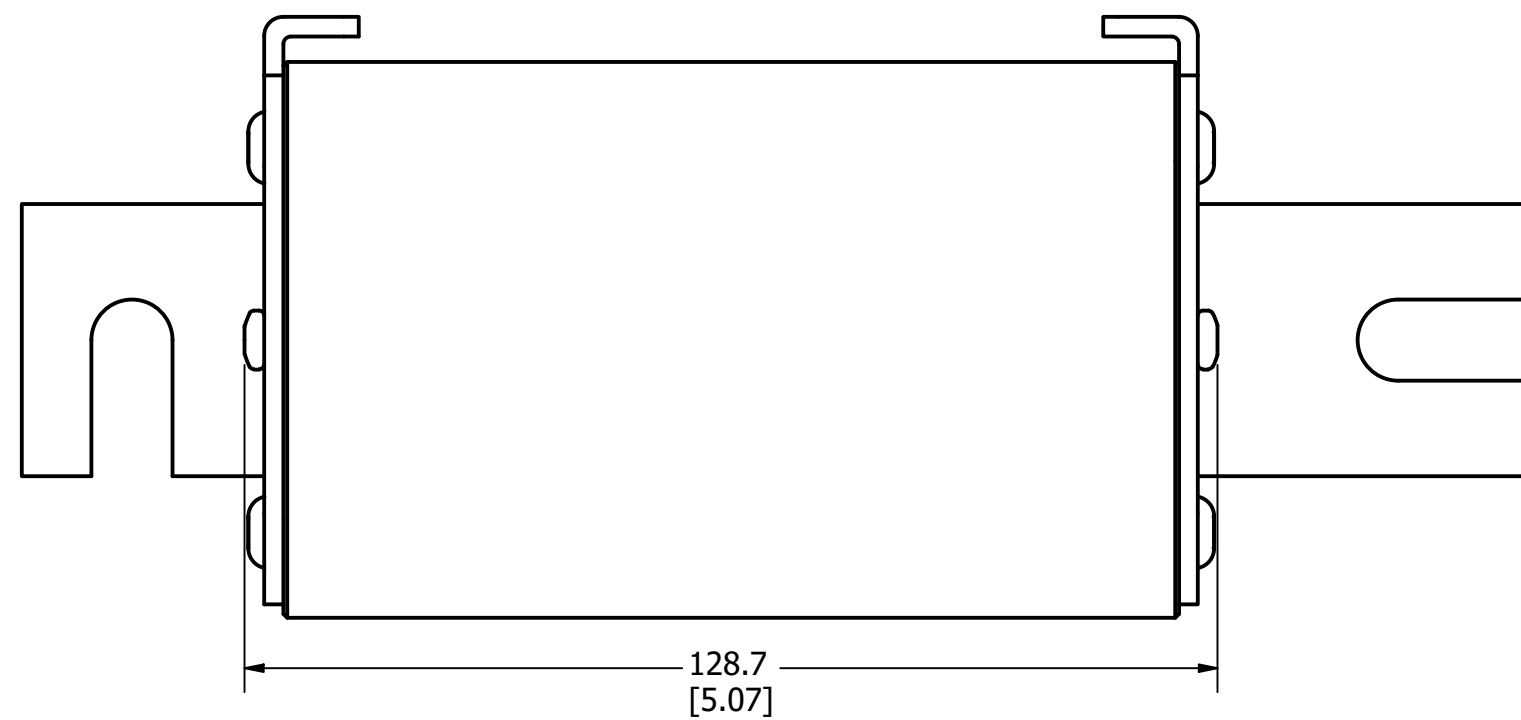
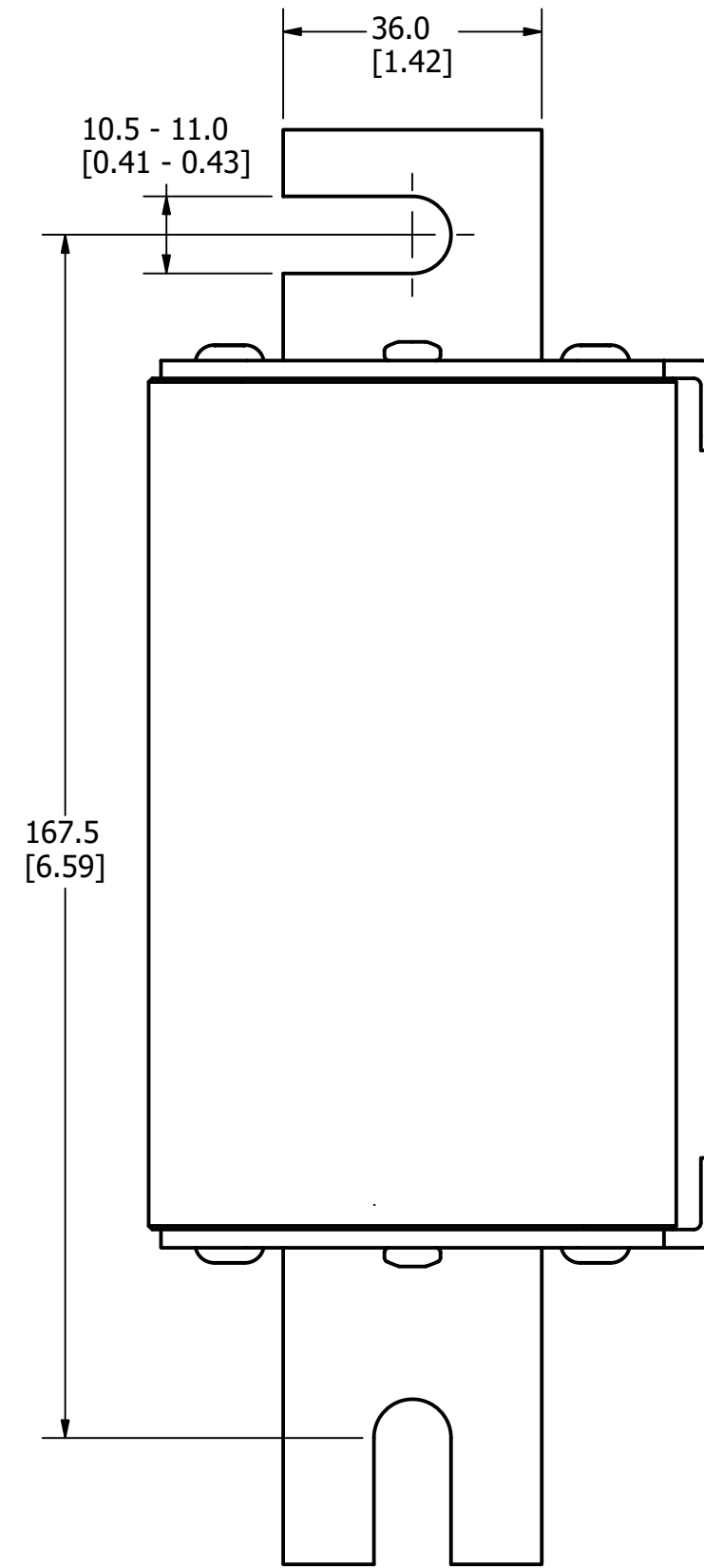
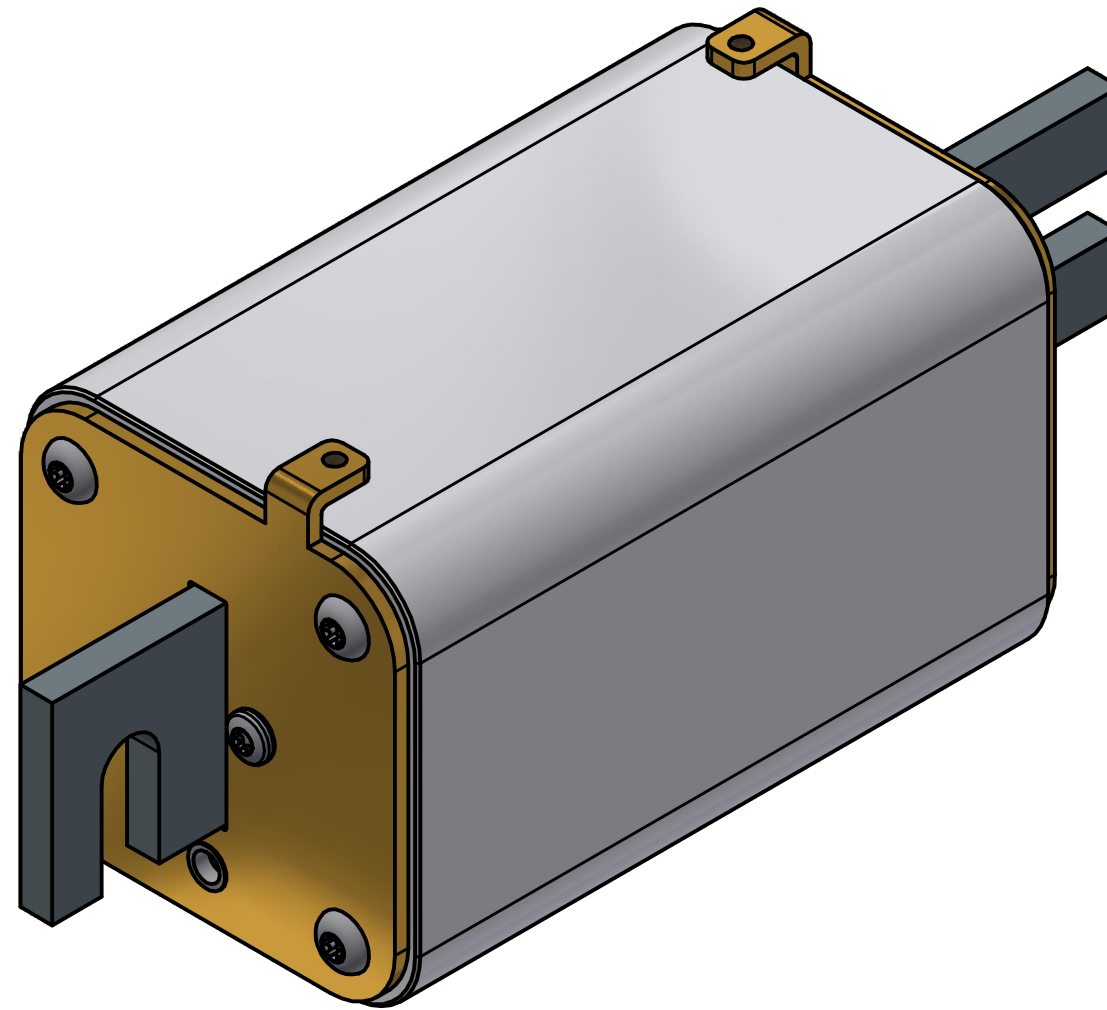
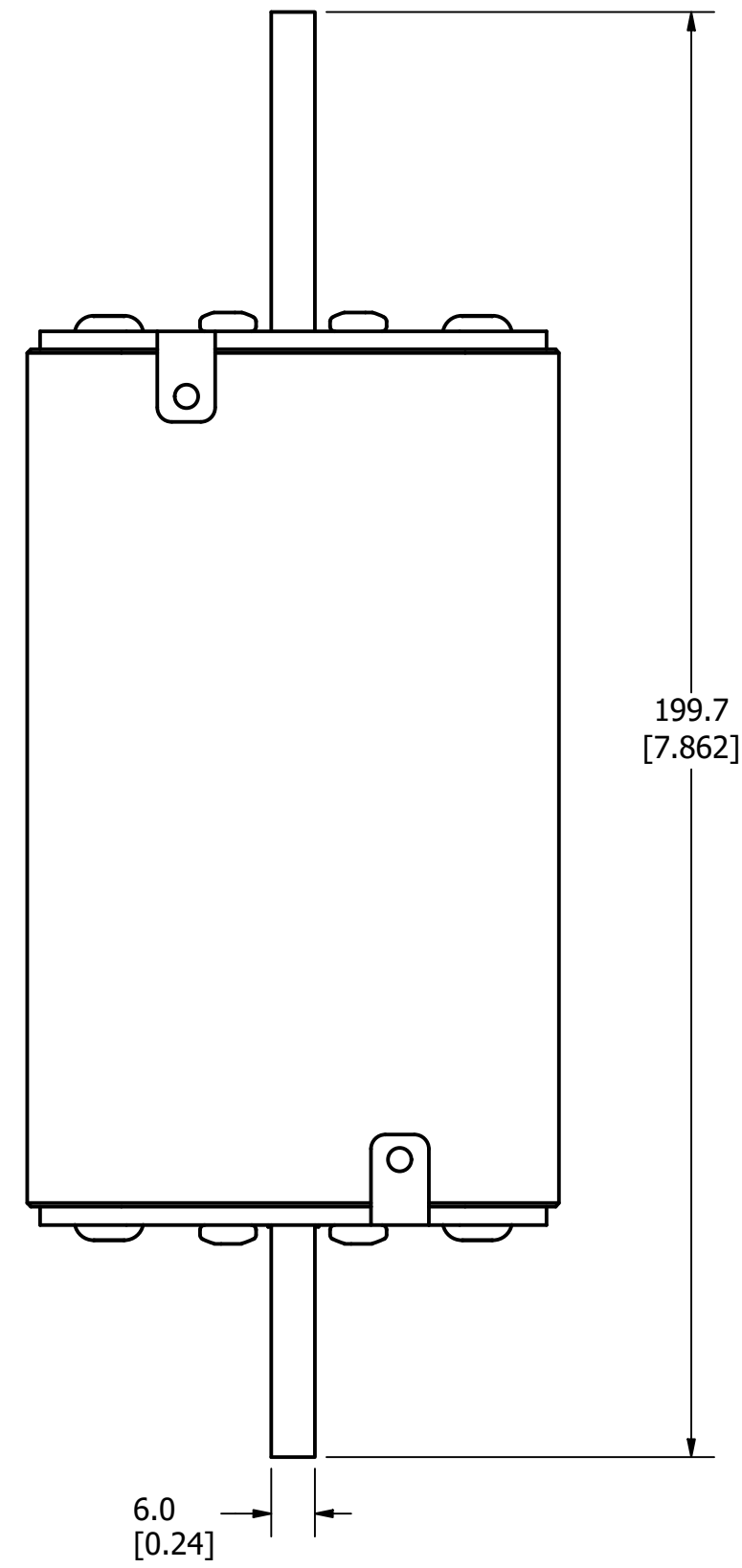

FOR REFERENCE ONLY

<S>	CRITICAL CHARACTERISTIC FOR PART SAFETY/COMPLIANCE		
●	DENOTES CRITICAL CHARACTERISTICS.		
CPK	DENOTES CPK DIMENSIONS, -MINIMUM CPK VALUE		
(ST)	DENOTES A CHARACTERISTIC THAT PROVIDES AN INDICATION OF PROCESS PERFORMANCE. PROCEDURE FOR MEASUREMENT AND TRACKING TO BE DEFINED IN LITTELFUSE INSPECTION INSTRUCTIONS.		
CP	DENOTES CP DIMENSIONS, -MINIMUM CP VALUE MUST BE WITHIN THE DIMENSIONAL LIMITATIONS SHOWN ON DRAWING AND INITIALLY LOCATED TO ALLOW FOR MAXIMUM TOOL LIFE.		
MATL SPEC		FINISH	
DRW JMoler	DATE 12/31/1969	SCALE NTS	FINISH GOOD WT GRAMS/PIECE
UNLESS OTHERWISE SPECIFIED, DIMENSIONS ARE IN MILLIMETERS, DIMENSIONS IN BRACKETS [ ] ARE INCHES DIMENSIONING AND DO NOT INCLUDE PLATING. TOLERANCING TO BE INTERPRETED IN ACCORDANCE WITH ANSI Y14.5M-1994			
3RD ANGLE PROJECTION			
TITLE ESR SIZE 3XL (DB) FUSE OUTLINE			
Littelfuse® CHICAGO, ILLINOIS 60631		REVISION A	DRWG NO. OL-ESR3XLDB0000

C