

POWR-SPEED® Fuse

ESR Series High-Speed Square Body

Battery Protection Fuses • 1500 V Dc • Class aBat • 125 - 630 A

c    **REACH HF**



Description

The Littelfuse Energy Storage Rack (ESR) series of fuses is designed specifically to protect battery racks in energy storage systems, inverters, and many other dc applications. The 1500 V dc high-speed square body fuse is extremely fast-acting to respond quickly to a range of fault currents to safeguard the battery module or other devices.

This Class aBat partial range fuse has superior short circuit protection and a low minimum breaking capacity (MBC)—from 300 % or 3 times the fuse’s rated current to 250 kA—to cover a range of over currents that traditional high-speed partial range fuses do not protect against.

The ESR fuse safely interrupts most faults in a battery storage system to avoid catastrophic failures and costly shutdowns.

Features & Benefits

FEATURES	BENEFITS
High dc interrupting rating	Provides superior short-circuit protection and the ability to scale-up systems without the need to redesign the existing circuit protection, saving time and costs
Low minimum breaking current	Offers easy coordination with battery modules and reduces size and rating of dc contactors to save space and costs
Extremely fast acting	Delivers high-speed performance
Low watt loss	Maximizes efficiency by preventing energy loss and minimizing the wasted power of components
Conforms to the IEC 60269-7 battery standard	Specifically design to safeguard evolving battery technologies with fuse circuit protection
Compact NH 1XL and 3XL size	Saves space and offers design flexibility

Applications

- Battery energy storage systems (BESSs)
 - Battery Protection Unit (BPU) and battery racks
- Power conversion systems
- Dc common bus systems
- Hybrid PV-BESS inverters

POWR-SPEED® Fuse

ESR Series High-Speed Square Body

Specifications

Voltage Rating	1500 V dc
Amperage Rating	125 - 630 A
Interrupting Rating	250 kA
Time Constant	</= 3 ms
Mounting	Bolted-blade style, DIN-blade style
Material	Body: ceramic Contacts: plated copper (bladed)
Applicable Standards	UL 248-13, IEC 60269-7
Environmental	RoHS Compliant, REACH, Halogen Free
Operating Temperature	-55 °C to +125 °C (-67 °F to +257 °F)
Storage Temperature	Up to +35 °C (+95 °F) with relative humidity <65 %
Country of Origin	Mexico

Certification & Compliance

cURus	cURus Recognized (File: E71611)
CE	EU_DOC-ESR_DB_UB_240201
RoHS	RoHS 2 Directive 2011/65/EU/ Directive (EU) 2015/863
REACH	Regulation (EC) 1907/2006
Halogen Free	Yes

Ordering Information - DIN Blade

CASE SIZE	CATALOG NUMBER	ORDERING NUMBER	UPC	BOX QUANTITY	WEIGHT
NH 1XL	ESR1XLDB0125	ESR1XLDB0125X	07945830630	1 pc/box	2.2 lbs. (998 g.)
NH 1XL	ESR1XLDB0160	ESR1XLDB0160X	07945837030	1 pc/box	2.2 lbs. (998 g.)
NH 1XL	ESR1XLDB0200	ESR1XLDB0200X	07945837032	1 pc/box	2.2 lbs. (998 g.)
NH 1XL	ESR1XLDB0250	ESR1XLDB0250X	07945837782	1 pc/box	2.2 lbs. (998 g.)
NH 3XL	ESR3XLDB0250	ESR3XLDB0250X	07945837033	1 pc/box	4.4 lbs. (1996 g.)
NH 3XL	ESR3XLDB0315	ESR3XLDB0315X	07945837034	1 pc/box	4.4 lbs. (1996 g.)
NH 3XL	ESR3XLDB0350	ESR3XLDB0350X	07945837035	1 pc/box	4.4 lbs. (1996 g.)
NH 3XL	ESR3XLDB0400	ESR3XLDB0400X	07945837036	1 pc/box	4.4 lbs. (1996 g.)
NH 3XL	ESR3XLDB0450	ESR3XLDB0450X	07945837037	1 pc/box	4.4 lbs. (1996 g.)
NH 3XL	ESR3XLDB0500	ESR3XLDB0500X	07945837038	1 pc/box	4.4 lbs. (1996 g.)
NH 3XL	ESR3XLDB0550	ESR3XLDB0550X	07945837780	1 pc/box	4.4 lbs. (1996 g.)
NH 3XL	ESR3XLDB0630	ESR3XLDB0630X	07945837778	1 pc/box	4.4 lbs. (1996 g.)

POWR-SPEED® Fuse

ESR Series High-Speed Square Body

Ordering Information - Bolted Blade

CASE SIZE	CATALOG NUMBER	ORDERING NUMBER	UPC	BOX QUANTITY	WEIGHT
NH 1XL	ESR1XLUB0125	ESR1XLUB0125X	07945830629	1 pc/box	2.2 lbs. (998 g.)
NH 1XL	ESR1XLUB0160	ESR1XLUB0160X	07945837039	1 pc/box	2.2 lbs. (998 g.)
NH 1XL	ESR1XLUB0200	ESR1XLUB0200X	07945837040	1 pc/box	2.2 lbs. (998 g.)
NH 1XL	ESR1XLUB0250	ESR1XLUB0250X	07945837781	1 pc/box	2.2 lbs. (998 g.)
NH 3XL	ESR3XLUB0250	ESR3XLUB0250X	07945837042	1 pc/box	4.4 lbs. (1996 g.)
NH 3XL	ESR3XLUB0315	ESR3XLUB0315X	07945837043	1 pc/box	4.4 lbs. (1996 g.)
NH 3XI	ESR3XLUB0350	ESR3XLUB0350X	07945837044	1 pc/box	4.4 lbs. (1996 g.)
NH 3XL	ESR3XLUB0400	ESR3XLUB0400X	07945837045	1 pc/box	4.4 lbs. (1996 g.)
NH 3XL	ESR3XLUB0450	ESR3XLUB0450X	07945837046	1 pc/box	4.4 lbs. (1996 g.)
NH 3XL	ESR3XLUB0500	ESR3XLUB0500X	07945837048	1 pc/box	4.4 lbs. (1996 g.)
NH 3XL	ESR3XLUB0550	ESR3XLUB0550X	07945837779	1 pc/box	4.4 lbs. (1996 g.)
NH 3XL	ESR3XLUB0630	ESR3XLUB0630X	07945837777	1 pc/box	4.4 lbs. (1996 g.)

Electrical Specifications

CASE SIZE	CATALOG NUMBER		AMPERE RATING (A)	VOLTAGE RATING (V)	INTERRUPTING RATING	MINIMUM BREAKING CAPACITY (A)	MELTING (PRE-ARC) I ² T (A ² S)	TOTAL CLEARING I ² T (A ² S) AT RATED VOLTAGE	WATTS LOSS AT 100 % RATED CURRENT (W)	AGENCY CERTIFICATION
	BOLTED BLADE (UB)	DIN BLADE (DB)		DC	DC			DC		cURus
NH 1XL	ESR1XLUB0125	ESR1XLDB0125	125	1500	250 kA	375	1850	30700	53	•
NH 1XL	ESR1XLUB0160	ESR1XLDB0160	160	1500	250 kA	480	3400	48400	50	•
NH 1XL	ESR1XLUB0200	ESR1XLDB0200	200	1500	250 kA	600	5100	62800	89	•
NH 1XL	ESR1XLUB0250	ESR1XLDB0250	250	1500	250 kA	750	9000	95300	107	•
NH 3XL	ESR3XLUB0250	ESR3XLDB0250	250	1500	250 kA	750	9500	143400	96	•
NH 3XL	ESR3XLUB0315	ESR3XLDB0315	315	1500	250 kA	945	17500	279500	102	•
NH 3XL	ESR3XLUB0350	ESR3XLDB0350	350	1500	250 kA	1050	23000	232400	133	•
NH 3XL	ESR3XLUB0400	ESR3XLDB0400	400	1500	250 kA	1200	29000	324700	158	•
NH 3XL	ESR3XLUB0450	ESR3XLDB0450	450	1500	250 kA	1350	42000	581800	156	•
NH 3XL	ESR3XLUB0500	ESR3XLDB0500	500	1500	250 kA	1500	60000	843000	164	•
NH 3XL	ESR3XLUB0550	ESR3XLDB0550	550	1500	250 kA	1650	85000	1207000	164	•
NH 3XL	ESR3XLUB0630	ESR3XLDB0630	630	1500	250 kA	1890	124800	1402000	191	•

POWR-SPEED® Fuse

ESR Series High-Speed Square Body

Dimensions

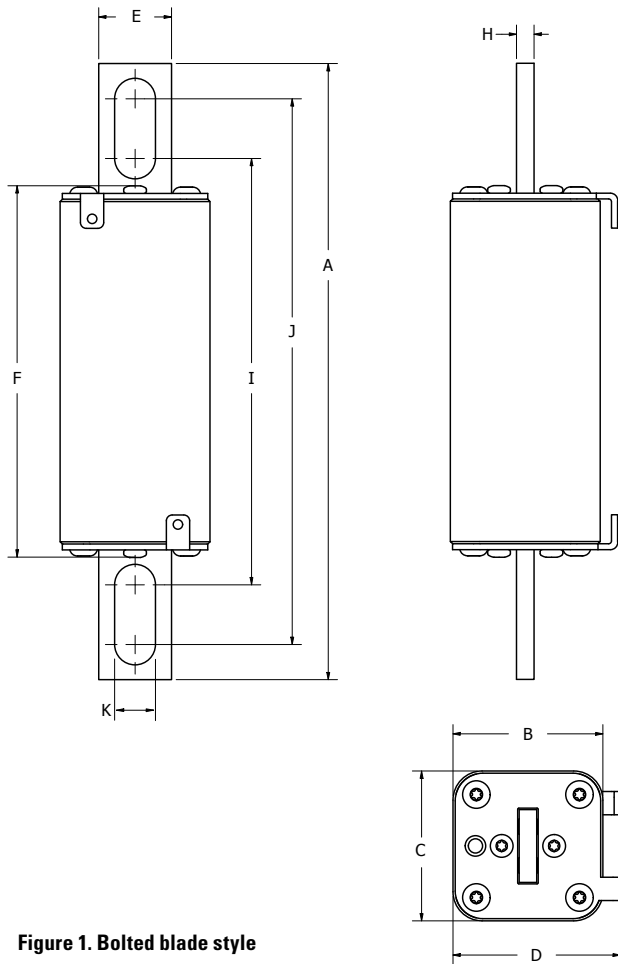

Figure 1. Bolted blade style

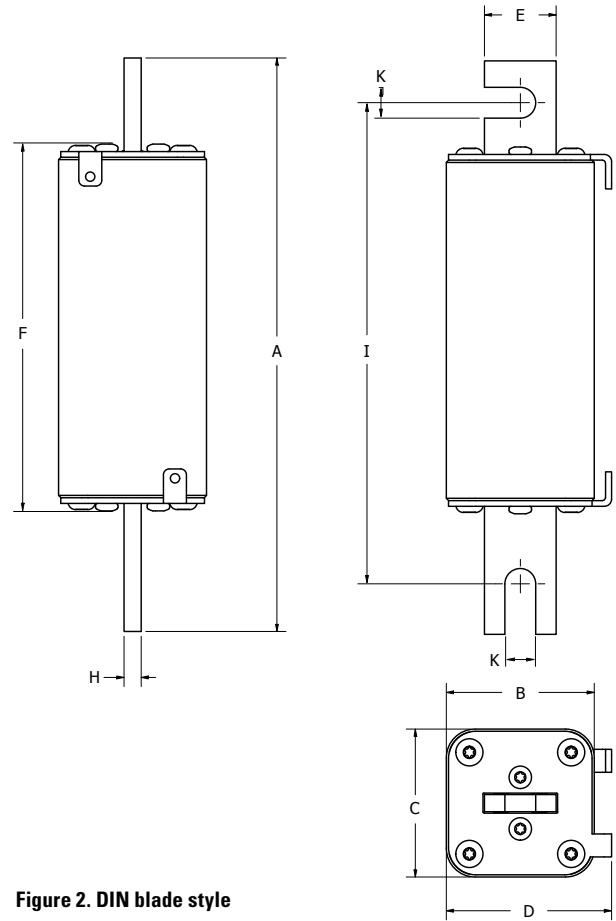

Figure 2. DIN blade style

DIMENSIONS MM (IN)														
CASE SIZE	MOUNTING STYLE	FIGURE	A	B	C	D	E	F	H	I	J	K	RECOMMENDED FASTENER	RECOMMENDED TORQUE
NH 1XL	BOLTED BLADE (UB)	1	211.7 (8.33)	51.5 (2.03)	51.5 (2.03)	57.5 (2.26)	25.0 (0.98)	127.7 (5.03)	6.0 (0.24)	146.5 (5.77)	187.5 (7.38)	14.0 (0.55)	12 (1/2)	64 Nm
NH 1XL	DIN BLADE (DB)	2	199.7 (7.86)	51.5 (2.03)	51.5 (2.03)	57.5 (2.26)	25.0 (0.98)	127.7 (5.03)	6.0 (0.24)	167.5 (6.59)	-	10.5-11.0 (0.41-0.43)	10 (3/8)	26 Nm
NH 3XL	BOLTED BLADE (UB)	1	213.9 (8.42)	73.5 (2.89)	73.5 (2.89)	79.5 (3.13)	36.0 (1.42)	128.7 (5.07)	6.0 (0.24)	153.5 (6.04)	186.5 (7.34)	16.0 (0.63)	14 (9/16)	92 Nm
NH 3XL	BOLTED BLADE (DB)	2	199.7 (7.86)	73.5 (2.89)	73.5 (2.89)	79.5 (3.13)	36.0 (1.42)	128.7 (5.07)	6.0 (0.24)	167.5 (6.59)	-	10.5-11.0 (0.41-0.43)	10 (3/8)	26 Nm

POWR-SPEED® Fuse

ESR Series High-Speed Square Body

Time Current Curve (1XL Case Size)

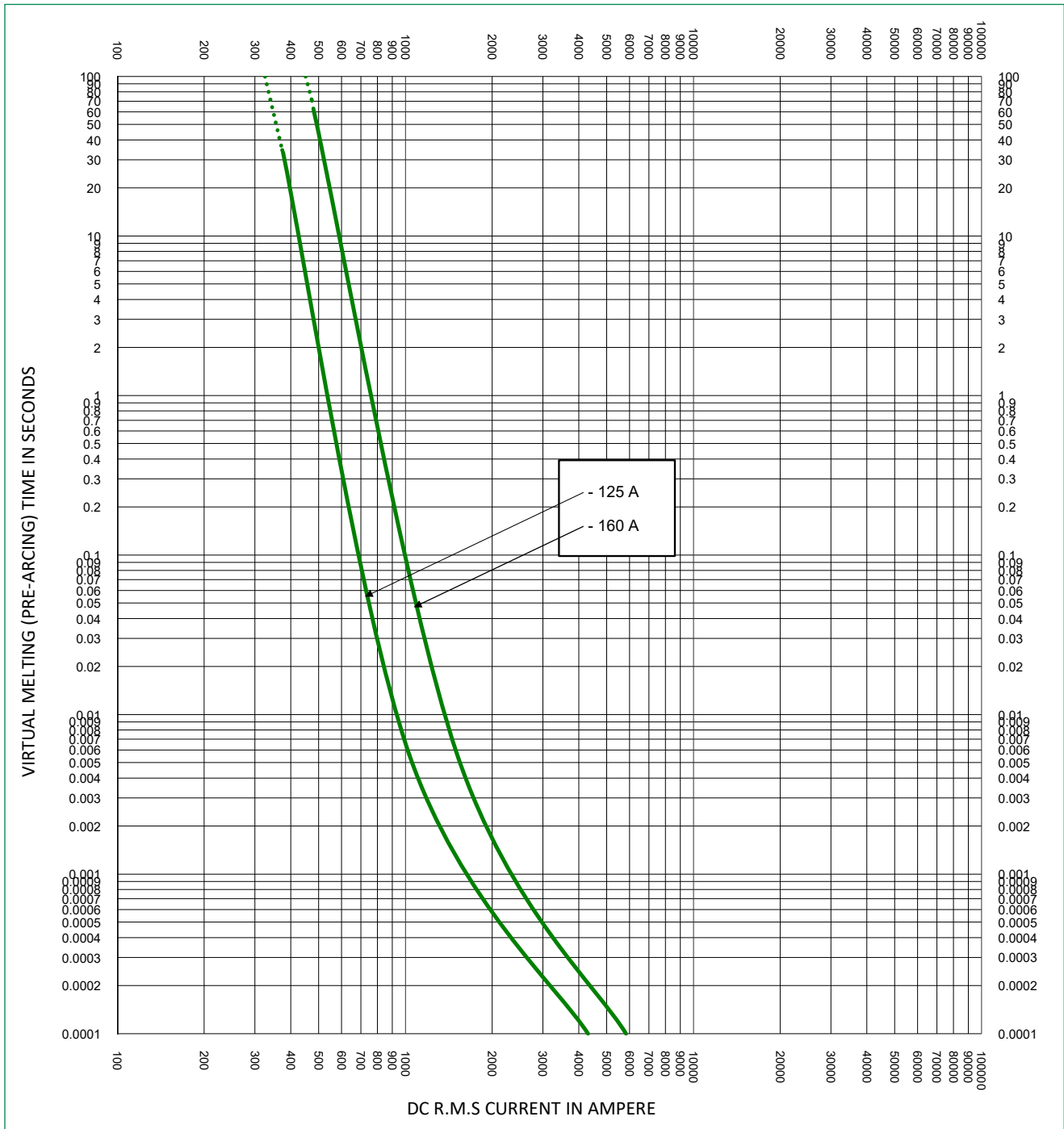

POWR-SPEED® Fuse

ESR Series High-Speed Square Body

Time Current Curve (1XL Case Size)

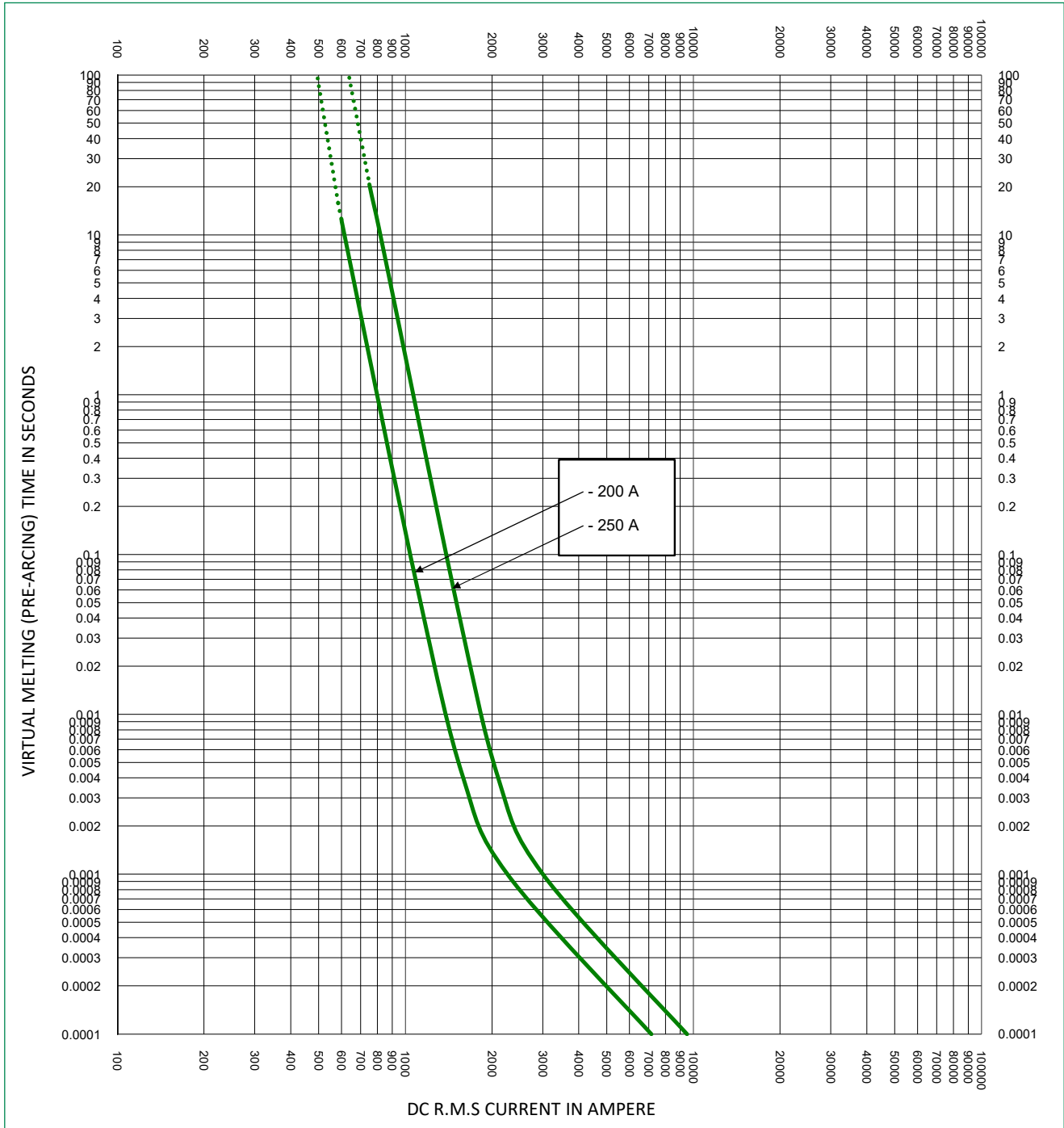

POWR-SPEED® Fuse

ESR Series High-Speed Square Body

Time Current Curve (3XL Case Size)

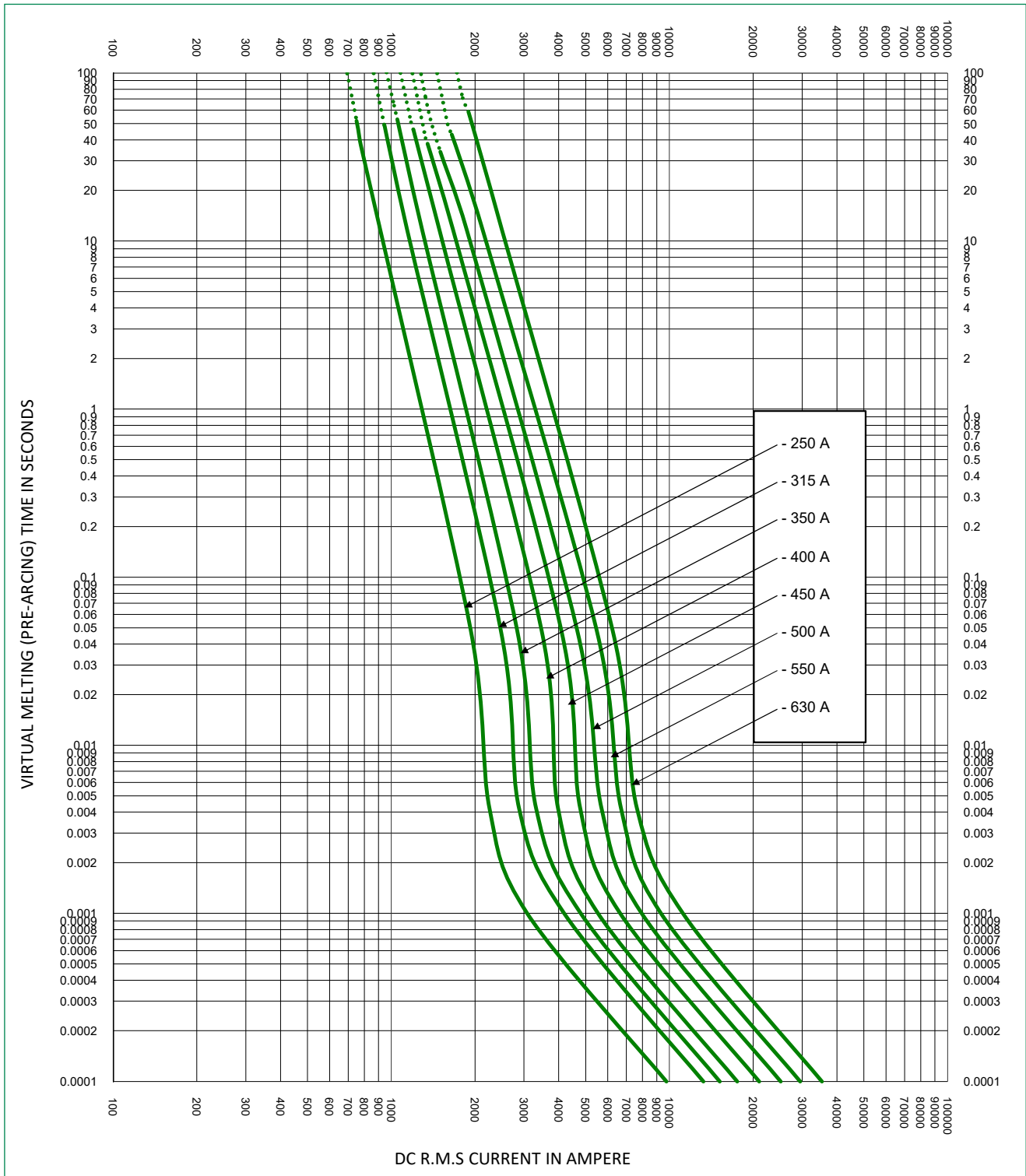

POWR-SPEED® Fuse

ESR Series High-Speed Square Body

Total Clearing I²T Correction Factor Curve (1XL and 3XL)

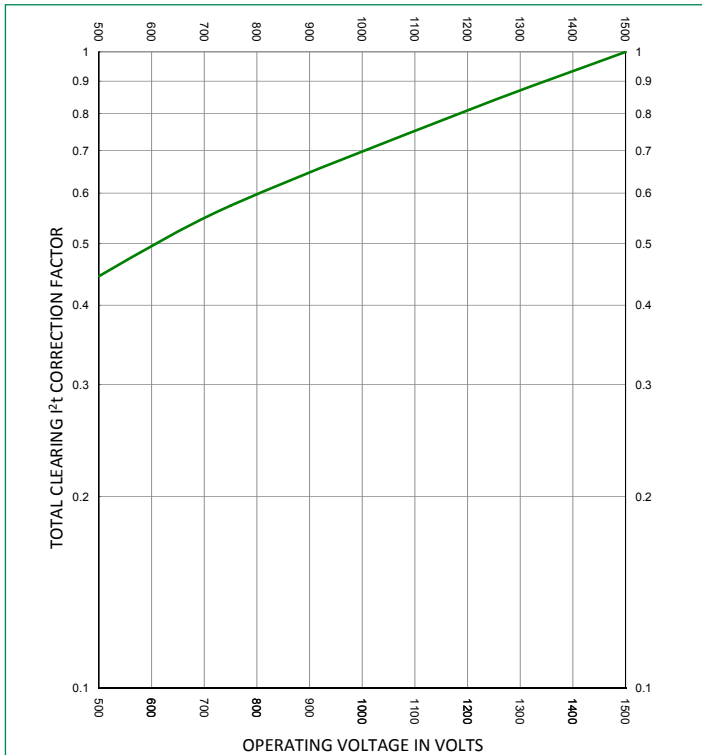

Temperature Derating Curve

Ambient temperature: temperature of air immediately surrounding fuse

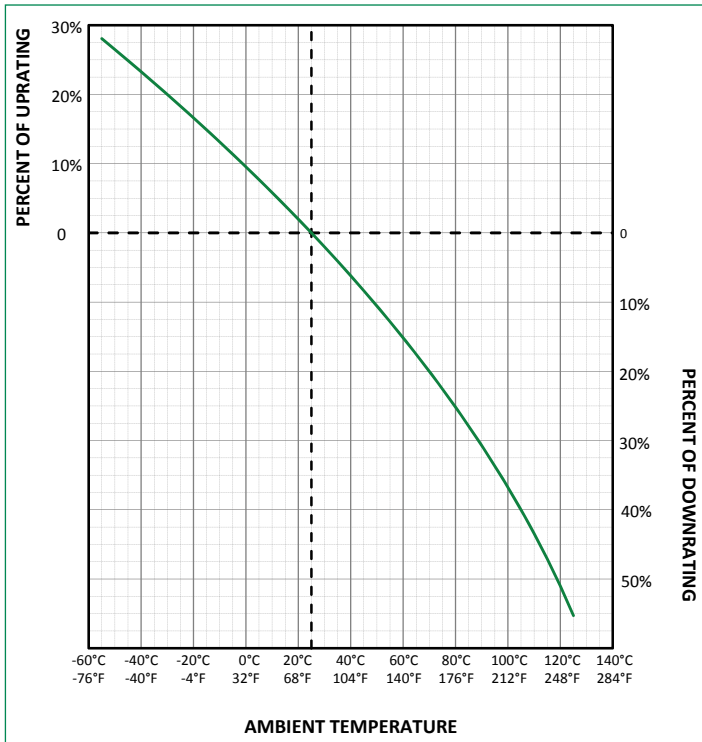

POWR-SPEED® Fuse

ESR Series High-Speed Square Body

Watts Loss Correction Factor Curve

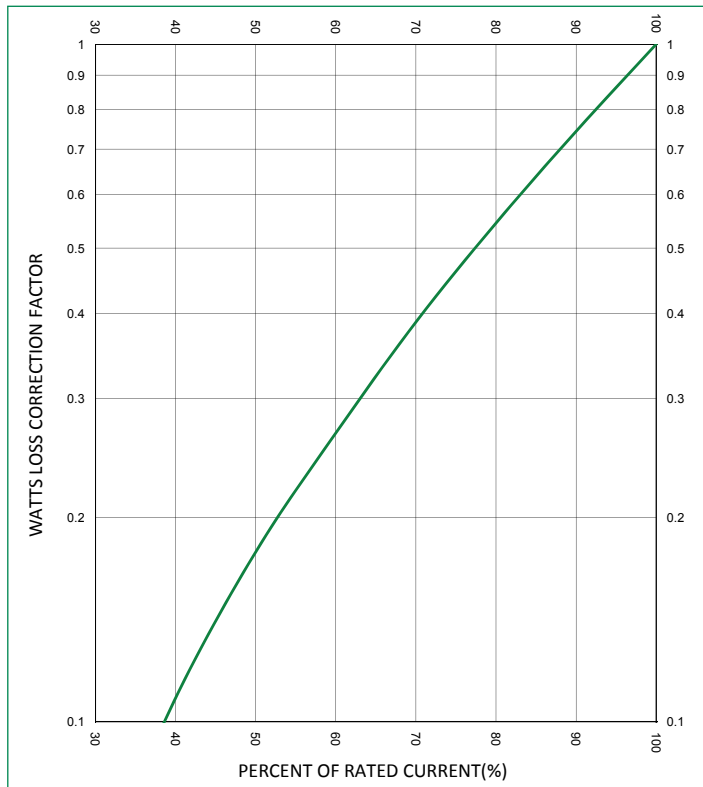

Disclaimer Notice – Information furnished is believed to be accurate and reliable. However, users should independently evaluate the suitability of and test each product selected for their own applications. Littelfuse products are not designed for, and may not be used in, all applications. Read complete Disclaimer Notice at www.littelfuse.com/product-disclaimer.