

OFF

Always mount accessories on position OFF

Installez toujours les accessoires en position OFF

Montar siempre los accesorios en posición OFF



Accessories / Accessoires / Accesorios

This switch can be complemented with the following accessories:
 Cet commutateur peut être complété avec les accessoires suivants:
 Este interruptor puede complementarse con los siguientes accesorios:

Mando / Handle / Poignée

LDM3SIB1 - Direct front handle / LDM3SSB1 - Side direct handle
 LDM3SAB1* - External front handle ON-OFF-TEST / LDM3SAB2* - External front handle ON-OFF
 LDM3SRB1* - External front handle red - yellow ON-OFF-TEST / LDM3SRB2* - External front handle red - yellow ON-OFF
 LDM3SBB1* - External side handle ON-OFF-TEST / LDM3SBB2* - External side handle ON-OFF
 LDM3SEB1* - External side handle red - yellow ON-OFF-TEST / LDM3SEB2* - External side handle red - yellow ON-OFF
 *Shaft included (□7mm / L=177mm)

Contactos Aux. / Aux. contacts / Contacts aux.

LDM3AUB1 - 1N0+1NC

Cubrebornes / Shrouds / Cache-bornes

LDM3CU02 (3P) - LDM3CU03 (4P)

	M' +5% -10%	
	Nm	lbf-in
M4	1	8.85

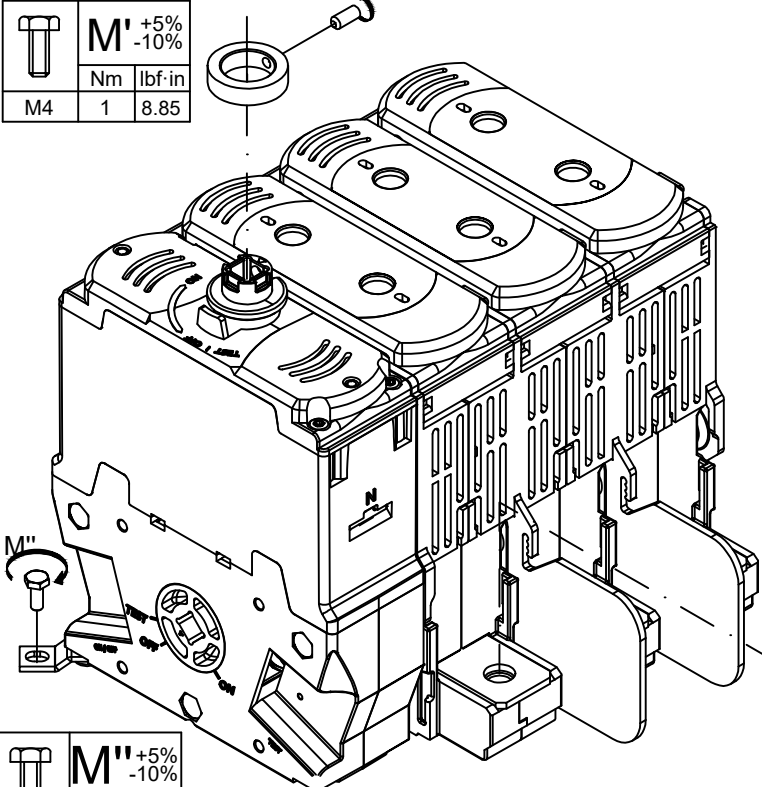

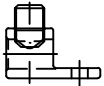

LDM3TLU01

2 x 

REF: 20209010

	M'' +5% -10%	
	Nm	lbf-in
M4	1,5	13,3

	M''' +5% -10%	
	Nm	lbf-in
Ch 3,5	0,8	7,1

	Wire / Câble Cable			M +5% -10%	
	lth	S range		Nm	lbf-in
60 A	mm ² AWG	6-50 10-2/0	M8	6	53

Desconexión neutro desconectable (Nd).
 Disconnection detachable neutral (Nd).
 Déconnexion neutre débranchable (Nd).

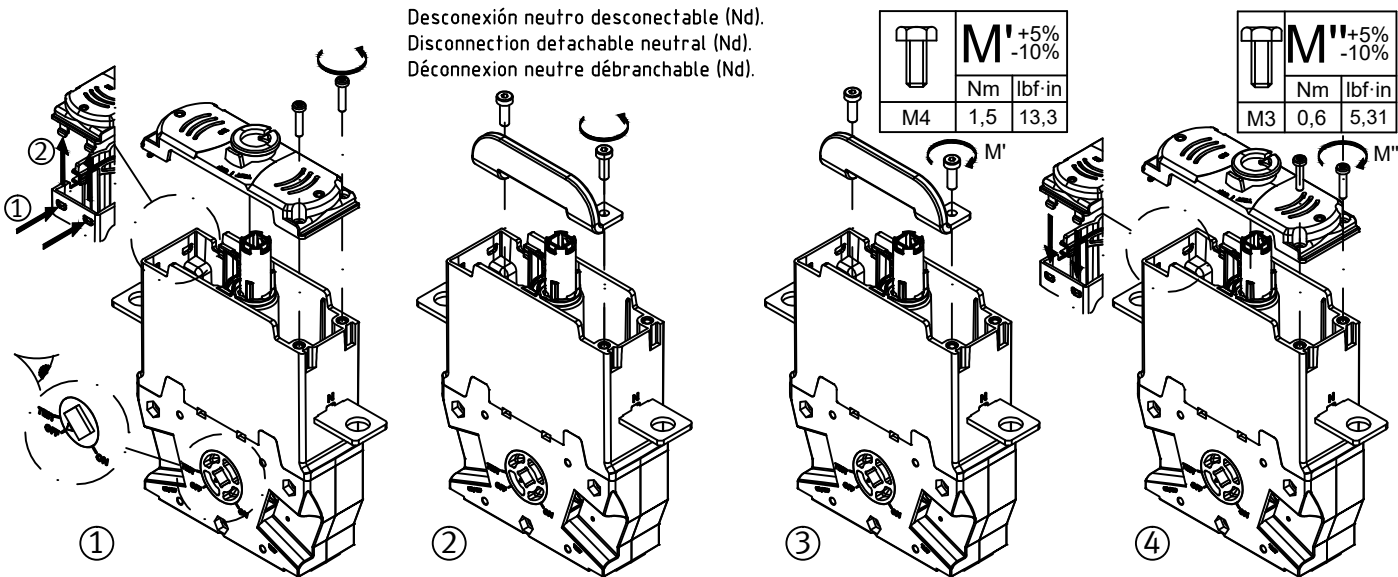

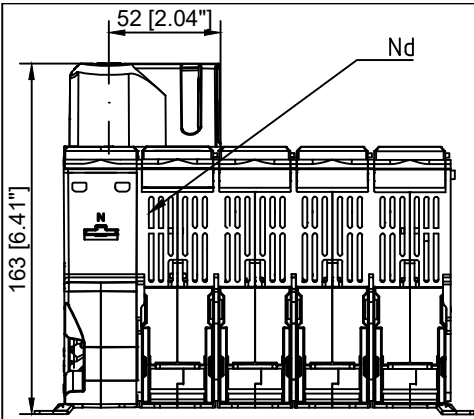

Warning for all models and amperages
 Consider this when installing horizontal
 Advertencia para todos los tamaños
 Considerar cuando se instale en horizontal
 Avertissement pour toutes les tailles
 Considérer lors de l'installation horizontal

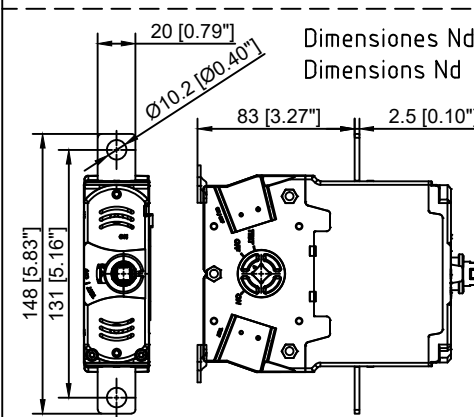
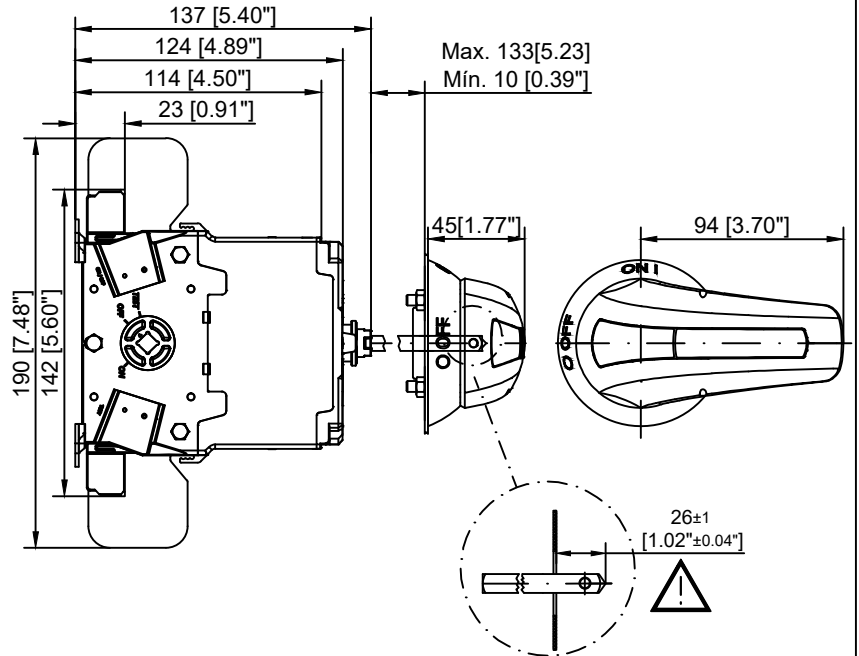
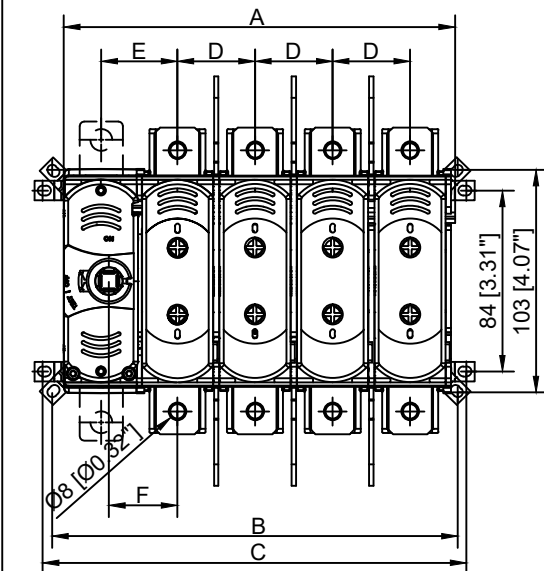
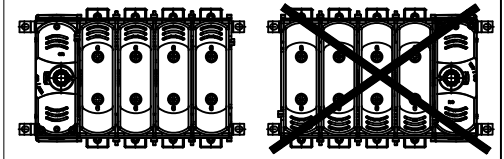

		A		B		C		D		E		F	
		mm	in	mm	in	mm	in	mm	in	mm	in	mm	in
60 Amp Class J Fuse	3P/ 3P+ND	146	5.75	152	5.98	160	6.30	36	1.42	35	1.38	32	1.25
	3P+N	182	7.16	188	7.40	196	7.72						



DANGER / PELIGRO

HAZARDOUS VOLTAGE

- This equipment must be installed and serviced only by qualified electrical personnel.
- Turn off all power supplying units before working on or inside this equipment.
- Always use a properly rated voltage sensing device to confirm power is off.
- Re install all devices, doors and covers before turning on power to this equipment.
- Maintain electrical clearances between cable and energized components.
- The installation must be performed according to local, national and international valid safety regulations.

FAILURE TO FOLLOW THESE INSTRUCTIONS MAY RESULT IN SERIOUS PERSONAL INJURY OR DEATH

TENSION DANGEREUSE

- L'installation et l'entretien de cet appareil ne doivent être effectués que par du personnel qualifié.
- Coupez l'alimentation de cet appareil avant d'y travailler.
- Utilisez toujours un dispositif de détection de tension à valeur nominale approprié pour confirmer que toute alimentation est coupée.
- Réinstallez tous les dispositifs, les portes et les couvercles avant de mettre cet appareil sous tension.
- Respectez les distances d'isolement électrique entre le câble et les pièces sous tension.
- L'installation doit être réalisée conformément à la réglementation en matière de sécurité valable local, national et international.

SI CES PRÉCAUTIONS NE SONT PAS RESPECTÉES, CELA POURRAIT ENTRAÎNER LA MORT OU DES BLESSURES GRAVES

TENSIÓN PELIGROSA

- Solamente el personal de mantenimiento eléctrico especializado deberá instalar y prestar servicios de mantenimiento a este equipo.
- Desenergice el equipo antes de realizar cualquier trabajo en él.
- Siempre utilice un dispositivo detector de tensión adecuado para confirmar la desenergización del equipo.
- Vuelva a colocar todos los dispositivos, las puertas y las cubiertas antes de energizar este equipo.
- Mantenga un espacio adecuado para la instalación eléctrica entre el cable y las piezas energizadas.
- La instalación debe ser realizada bajo los reglamentos y normas de seguridad locales, nacionales e internacionales vigentes.

EL INCUMPLIMIENTO DE ESTAS PRECAUCIONES PODRÁ CAUSAR LESIONES GRAVES O LA MUERTE



Expertise Applied | Answers Delivered

LM3060