

**IX9908**  
**Design Considerations**  
**(European Voltage Version)**

## 1 Introduction

This application note provides general guidelines for designing an off-line LED driver using IXYS Integrated Circuits Division's IX9908. The IX9908 can be configured to drive an external MOSFET device in a quasi-resonant flyback converter power stage that provides a constant current output to a LED string while maintaining a high power factor.

This driver features a high voltage start-up circuit that eliminates the need for a  $V_{CC}$  resistor, thereby improving overall power dissipation. In addition, there are multiple safety features such as under-voltage lockout, over-voltage protection, digital soft-start, foldback correction, and cycle-by-cycle peak current limiting. The IX9908 is an excellent choice for many phase-cut dimming and high power-factor correction LED lighting applications.

Figure 1 IX9908 Block Diagram

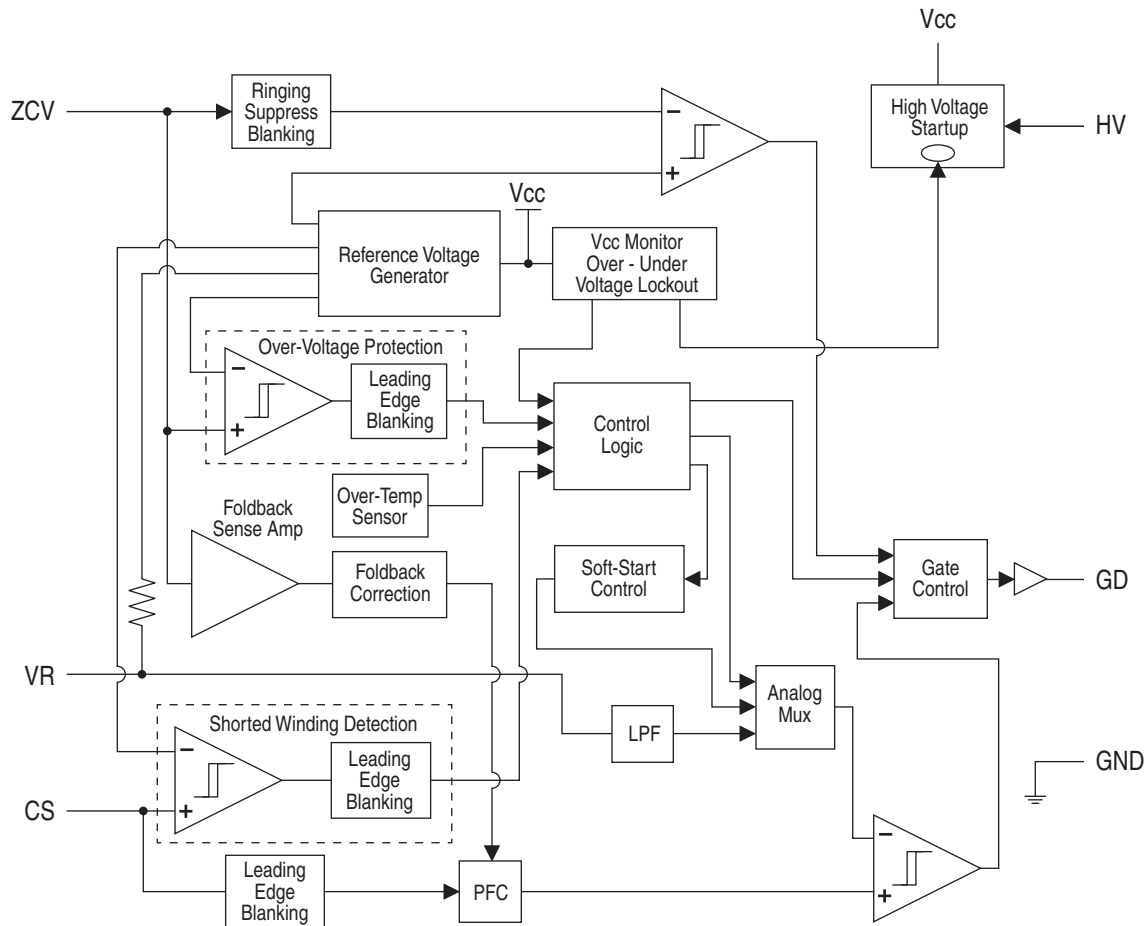
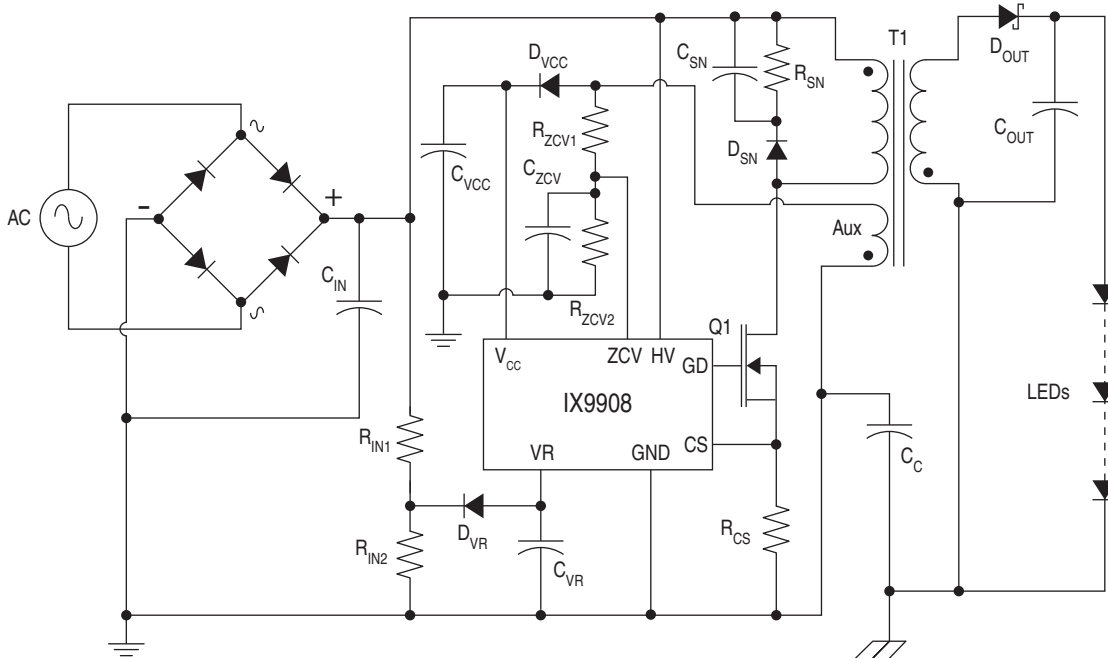

Figure 2 IX9908 Application Circuit



### 1.1 LED Driver Specifications

The following equations and component selections are based on the following LED driver specifications:

Parameter	Symbol	Rating	Units
AC Input Voltage			
Minimum Voltage	$V_{AC\_min}$	190	$V_{rms}$
Maximum Voltage	$V_{AC\_max}$	265	
AC Input Frequency	$f_{AC}$	50	Hz
Auxiliary Voltage	$V_{aux\_max}$	18	V
Auxiliary Current	$I_{aux\_max}$	30	mA
LED String Voltage	$V_{LEDstring}$	40	V
LED String Current	$I_{LED\_max}$	300	mA
Estimated Efficiency	$\eta$	85	%
Oscillator Frequency	$f_S$	100	kHz
Power Factor	PF	98	%
Maximum Duty Cycle	$D_{max}$	50	%

## 2 Component Selection

### 2.1 DC Bulk Voltage at Low and High Line

$$V_{DC\_bulk\_min} = \sqrt{2} \cdot V_{AC\_min} = \sqrt{2} \cdot 190V_{AC} \approx 269V$$

$$V_{DC\_bulk\_max} = \sqrt{2} \cdot V_{AC\_max} = \sqrt{2} \cdot 265V_{AC} \approx 375V$$

### 2.2 Output Power Calculation

$$P_{out} = V_{LEDstring} \cdot I_{LED\_max}$$

$$P_{out} = 40V \cdot 300mA = 12W$$

### 2.3 Input Power Calculation

$$P_{in} = \frac{P_{out}}{\eta \cdot PF}$$

$$P_{in} = \frac{12W}{0.85 \cdot 0.98} \approx 14.41W$$

### 2.4 Primary Inductor Currents Calculation

$$I_{pri\_peak} = \frac{\sqrt{2} \cdot V_{AC\_min} \cdot D_{max}}{L_{pri} \cdot f_S}$$

$$I_{pri\_peak} = \frac{269V \cdot 0.5}{4.535mH \cdot 100kHz} \approx 0.297A_{peak}$$

For  $L_{pri}$ , see **3.1 Primary Inductance Calculation**.

$$I_{rms} = I_{pri\_peak} \cdot \sqrt{\frac{D_{max}}{3}}$$

$$I_{rms} = 0.297A_{peak} \cdot \sqrt{\frac{0.5}{3}} \approx 0.121A_{rms}$$

Note that duty cycle above 50% will result in converter stability issues such as sub-harmonic oscillations.

### 2.5 Reflected Flyback Voltage Calculation

$$V_{ro} = \frac{V_{LEDstring} + V_f}{\left(\frac{N_S}{N_P}\right)} = \frac{40V + 0.7V}{0.1515} \approx 269V$$

See **3.2 Determine Transformer Turns Ratio** for  $N_S/N_P$  ratio.

### 2.6 Input Capacitor, $C_{IN}$

The IX9908 is designed to operate without the need of a large bulk capacitor. This operating method enables the input current to form a triangular shape that closely

follows the rectified AC line voltage, enabling a very high power factor of up to 98% with low total harmonic distortion (THD).

A small, 0.1 $\mu$ F, 630V<sub>DC</sub> polyester film filter capacitor should be adequate for this application.

### 2.7 Input Rectifier Bridge

The breakdown voltage for this bridge is based on the maximum input voltage.

$$V_{bridge} = \sqrt{2} \cdot 265V_{AC} \cdot 1.5 \approx 562V$$

Select the next higher standard voltage, 600V.

The rectifier bridge is exposed to high surge currents, so select a bridge that can handle at least five times the  $I_{rms}$  input current. In this case, a 0.6A bridge would be sufficient.

### 2.8 Calculate MOSFET Voltage Rating

$$V_{DS} = V_{DC\_bulk\_max} + V_{ro} + V_{spike}$$

Assume that  $V_{spike} = 50V$ .

$$V_{DS} = 375V + 269V + 50V \approx 694V$$

Due to the voltage spikes resulting from leakage inductance, the MOSFET should be selected with an adequate margin. A good choice would be between 800V and 900V.

### 2.9 Design RCD Snubber

In a flyback topology, a snubber circuit is required to clamp the voltage caused by the leakage inductance, which is present in all transformers. Leakage inductance is highly dependent on the transformer construction, so care should be taken to keep it less than 2% of primary inductance. When no leakage inductance is known, a leakage inductance value of 90 $\mu$ H (2% of 4.535mH) can be used as a starting point to calculate the snubber's resistor, capacitor, and diode values.

$D_{SN}$  is selected as 1N4007GP (1000V, 1A axial lead).

Energy stored in the leakage inductance  $L_e$ :

$$W1 = 0.5L_e \cdot I_{rms}^2 = 0.5 \cdot 90\mu H \cdot 0.121^2 \approx 0.66\mu J$$

Average power transferred from W1 to the snubber:

$$P1 = W1 \cdot f_S = 0.66\mu J \cdot 100kHz \approx 66mW$$

$$V_{max} = V_{DC\_bulk\_max} + V_{ro} + V_{spike}$$

$$V_{max} = 375V + 269V + 50V = 694V$$

- $V_{spike} = 50V$
- $V_{ro} = 269V$

Limiting the voltage to 694V.

$$V_{SN} = 694V - 269V = 425V$$

$$R_{SN} = \frac{V_{SN}^2}{P1} = \frac{425V^2}{66mW} \approx 2.7M\Omega$$

$$C_{SN} = \frac{T_S}{R_{SN}} = \frac{10\mu s}{2.7M\Omega} \approx 3.7pF$$

$$C_{SN} \gg \frac{T_S}{R_{SN}} = \frac{1}{f_S \cdot R_{SN}} = \frac{1}{100kHz \cdot 2.7M\Omega} \approx 3.7pF$$

For margin,  $C_{SN} = 1nF$  is selected. This value is a starting point, and might have to be adjusted to get the desired voltage spike suppression.

### 2.10 Over-Voltage Protection & Zero-Crossing Detection

The application schematic in **Figure 2 IX9908 Application Circuit** shows that the voltage from the auxiliary winding is connected to the zero crossing pin (ZCV), via RC network resistor  $R_{ZCV1}$ ,  $R_{ZCV2}$  and  $C_{ZCV}$ . The circuit provides a delay so that switch-on can occur at the voltage valley, thus enhancing efficiency. The line voltage is sensed indirectly through the current in  $R_{ZCV1}$ .

The current equation is given by:

$$I_{ZCV} = \frac{V_{DC\_bulk\_min} \cdot N_A}{R_{ZCV1} \cdot N_P}$$

Solving for  $R_{ZCV1}$ :

$$R_{ZCV1} = \frac{V_{DC\_bulk\_min} \cdot N_A}{I_{ZCV} \cdot N_P}$$

From the  $V_{CS}$  vs.  $I_{ZCV}$  graph below we select  $I_{ZCV} = 1000\mu A$  as the recommended current. For  $N_A/N_P$  value, see **3.2 Determine Transformer Turns Ratio**.

$$R_{ZCV1} = \frac{269V}{1000\mu A} \cdot 0.0696 \approx 18.7k\Omega$$

**Figure 3**  $V_{CS}$  vs.  $I_{ZCV}$

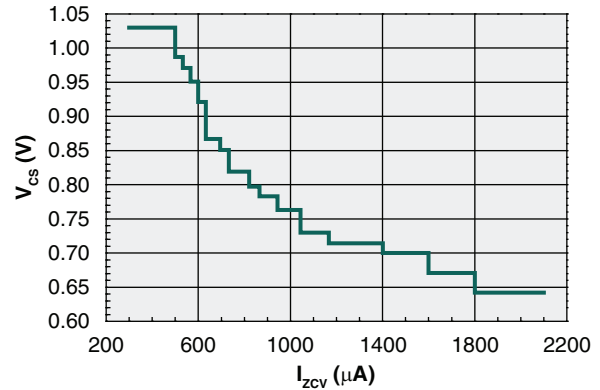

The over voltage detection can be programmed by  $R_{ZCV2}$  resistor. The output,  $V_{LEDstring}$ , is 40V, so select an over voltage protection of 50V, and from the datasheet,  $V_{ZCVOVP} = 3.7V$

$$R_{ZCV2} = \frac{R_{ZCV1} \cdot V_{ZCVOVP}}{V_{oovpth} - V_{ZCVOVP}}$$

$$R_{ZCV2} = \frac{18.7k\Omega \cdot 3.7V}{50V - 3.7V} \approx 1.494k\Omega$$

The delay capacitor can be approximated:

$$C_{ZCV} = t_{RC} \cdot \frac{R_{ZCV1} + R_{ZCV2}}{R_{ZCV1} \cdot R_{ZCV2}}$$

$$C_{ZCV} = 1\mu s \cdot \left( \frac{18.7k\Omega + 1.494k\Omega}{18.7k\Omega \cdot 1.494k\Omega} \right) \approx 723pF$$

Where  $t_{RC} = 1\mu s$  (see IX9908 data sheet).

### 2.11 Primary Peak Current Control

The value of the current sense resistor ( $R_{CS}$ ) can be selected by using following equation:

$$R_{CS} = \frac{V_{CSmax}}{I_{pri\_peak}}$$

$$R_{CS} = \frac{0.75V}{0.297A_{peak}} \approx 2.53\Omega$$

The  $R_{IN1}$  and  $R_{IN2}$  resistor values can be selected to scale the input voltage at the  $V_R$

pin. The  $R_{IN1}$  resistor is selected with consideration of losses and high power factor correction. In this example we select  $R_{IN1} = 2040k\Omega$ . Select two standard resistors,  $1.00M\Omega$  and  $1.04M\Omega$ , package size 1206.

The  $R_{IN2}$  value can be calculated:

$$R_{IN2} = \frac{R_{IN1} \cdot R_{CS} \cdot G_{PWM} \cdot I_{pri\_peak}}{V_{DC\_bulk\_min} - (G_{PWM} \cdot I_{pri\_peak} \cdot R_{CS})}$$

$R_{IN2} = 17.3k\Omega$ . Select the next standard value,  $17.4k\Omega$ , where:

PWM-Op gain,  $G_{PWM} = 3$  (from the IX9908 data sheet).

Select the  $C_{VR}$  capacitor to be  $2.2nF$  and the  $D_{VR}$  diode can be BAS16, 100V, or equivalent.

### 2.12 Selection of $V_{CC}$ Capacitor and Auxiliary Blocking Diode

In this application, a simple and inexpensive power supply for the IC is made from the auxiliary winding by using a blocking diode and a capacitor.

The auxiliary  $V_{CC}$  diode blocking voltage can be calculated:

$$V_{DV_{cc}} > \left( \sqrt{2} \cdot V_{AC\_max} \cdot \frac{N_A}{N_P} \right) + V_{aux\_max}$$

$$V_{DV_{cc}} > (375V \cdot 0.0696) + 18V \approx 44V$$

In this case, BAS16, 100V, or equivalent, would be selected.

For a dimming application a  $22\mu F$  capacitor would be required: if there is no dimming requirement, then a  $10\mu F$  capacitor will suffice.

### 2.13 Output Schottky Diode and Capacitor

The Schottky output diode is exposed to large currents when the converter is operated in critical conduction mode, CCM. Care should be taken to ensure adequate margins for the voltage and current ratings.

The required blocking voltage for  $D_{OUT}$ :

$$V_{d\_out} > \left( \sqrt{2} \cdot 265V_{AC\_max} \cdot \frac{N_S}{N_P} \right) + V_{LEDstring}$$

$$V_{d\_out} > (375V \cdot 0.1515) + 40V \approx 97V$$

See **3.2 Determine Transformer Turns Ratio** for the  $N_S/N_P$  ratio. Select a Schottky diode with a 150V rating.

The output diode is exposed to large peak currents.

$$I_{d\_rms} = I_{rms} \cdot \sqrt{\frac{1 - D_{max}}{D_{max}}} \cdot \frac{V_{ro}}{V_{LEDstring} + V_f}$$

$$I_{d\_rms} \approx 0.121A_{rms} \cdot 1 \cdot 6.609 \approx 0.8A_{rms}$$

See **2.4 Primary Inductor Currents Calculation**. For adequate margin, select a  $3A_{rms}$  diode, such as STPS3150V.

The output capacitor can be selected based on the desired output voltage ripple. The dynamic resistance of the LED driven at a given current should also be considered, as this will determine the current ripple through the LED string.

In this application, the LEDs have a dynamic resistance of  $1\Omega$  measured at  $300mA$  operating current. 12 LEDs result in  $12\Omega$  of dynamic resistance.

$$V_{out\_rip} = I_{LED\_max} \cdot R_{dynamic}$$

$$V_{out\_rip} = 300mA \cdot 12\Omega = 3.6V_{pp}$$

The output capacitor can be approximated:

$$C_{out} = \frac{2 \cdot I_{LED\_max}}{V_{out\_rip} \cdot 2 \cdot \pi \cdot 100Hz}$$

$$C_{out} = \frac{2 \cdot 300mA}{3.6V_{pp} \cdot 2 \cdot \pi \cdot 100Hz} \approx 265\mu F$$

Select one  $270\mu F$  capacitor, EEV-FR1H271L. This capacitor is rated at  $105^\circ C$  for 10,000 hours with  $100kHz$  frequency.

### 3 Transformer Design

A step-by-step guide for transformer design will be presented here. Primary inductance and turns ratio will be calculated, and the appropriate wire size will be selected. The transformer core and coil former will be selected to support design power requirements, and a general guideline will be presented for transformer construction to achieve the best efficiency, and avoiding transformer saturation at higher temperatures.

#### 3.1 Primary Inductance Calculation

$$L_{pri} = \frac{(V_{DC} \text{ bulk}_{min} \cdot \eta \cdot D_{max})^2}{2 \cdot P_{IN} \cdot F_S}$$

$$L_{pri} = \frac{(269V \cdot 0.85 \cdot 0.5)^2}{2 \cdot 14.41W \cdot 100kHz} \approx 4.535mH$$

#### 3.2 Determine Transformer Turns Ratio

$$\frac{V_{LEDstring}}{V_{IN}} = \frac{N_S}{N_P} \cdot \frac{D_{max}}{1 - D_{max}}$$

Secondary to primary turns ratio:

$$\frac{N_S}{N_P} = \frac{V_{LEDstring} + V_f}{\sqrt{2} \cdot V_{AC_{min}}} \cdot \frac{1 - D_{max}}{D_{max}}$$

Where  $V_f$  is the voltage drop of the output diode.

$$\frac{N_S}{N_P} = \frac{40V + 0.7V}{\sqrt{2} \cdot 190V} \cdot \frac{1 - 0.5}{0.5} \approx 0.1515$$

The auxiliary to primary turns ratio:

$$\frac{N_A}{N_P} = \frac{V_{aux_{max}} + V_f}{\sqrt{2} \cdot V_{AC_{min}}} \cdot \frac{1 - D_{max}}{D_{max}}$$

$$\frac{N_A}{N_P} = \frac{18V + 0.7V}{\sqrt{2} \cdot 190V} \cdot \frac{1 - 0.5}{0.5} \approx 0.0696$$

The auxiliary to secondary turns ratio:

$$\frac{N_A}{N_S} = \frac{V_{aux_{max}} + V_f}{V_{LEDstring} + V_f}$$

$$\frac{N_A}{N_S} = \frac{18V + 0.7V}{40V + 0.7V} \approx 0.4595$$

#### 3.3 Determine Primary Winding Wire Size

The first step is to find the RMS current through the primary winding, which can be approximated with the following equation:

$$I_{rms} = I_{pri\_peak} \cdot \sqrt{\frac{D_{max}}{3}}$$

$$I_{rms} = 0.297A_{peak} \cdot \sqrt{\frac{0.5}{3}} \approx 0.121A_{rms}$$

The primary winding wire area can be calculated:

$$A_{w\_pri} = \frac{I_{rms}}{J_{max}} \approx \frac{0.121A_{rms}}{6A/mm^2} \approx 0.0202mm^2$$

Where  $J_{max}$  is the current density of a wire, which is stated by the wire manufacturer to be  $6A/mm^2$ .

The diameter is determined by the following formula:

$$\text{Wire Diameter} = 2 \cdot \sqrt{\frac{A_w}{\pi}} = \sqrt{\frac{A_w}{\pi/4}} \approx \sqrt{\frac{A_w}{0.7854}}$$

$$D_{w\_pri} \approx \sqrt{\frac{0.0202mm^2}{0.7854}} \approx 0.1604mm$$

From **Table 1: Wire Gauge Table** this is converted to 37 SWG.

#### 3.4 Determine Secondary Winding Wire Size

The peak current of secondary winding can be determined by the following formula:

$$I_{sec\_peak} = \frac{2 \cdot I_{LEDmax}}{1 - D_{max}} = \frac{2 \cdot 0.3A}{1 - 0.5} = 1.2A_{peak}$$

The RMS current can be found:

$$I_{sec\_rms} = I_{sec\_peak} \cdot \sqrt{\frac{1 - D_{max}}{3}} \approx 1.2A_{peak} \cdot 0.408 \approx 0.490A_{rms}$$

Calculate the secondary wire size:

$$A_{w\_sec} = \frac{I_{sec\_rms}}{6} \approx \frac{0.490A_{rms}}{6} \approx 0.0817mm^2$$

Calculate the secondary wire diameter:

$$D_{w\_sec} \approx \sqrt{\frac{0.0817mm^2}{0.7854}} \approx 0.323mm$$

Convert using **Table 1: Wire Gauge Table** to 29 SWG.

**3.5 Determine Auxiliary Winding Wire Size**

The maximum current in the auxiliary winding can be calculated using:

$$I_{aux\_peak} = \frac{2 \cdot I_{aux\_max}}{1 - D_{max}} = \frac{2 \cdot 30mA}{1 - 0.5} = 0.12A_{peak}$$

The RMS current can be calculated:

$$I_{aux\_rms} = I_{aux\_peak} \cdot \sqrt{\frac{1 - D_{max}}{3}} \approx 0.049A_{rms}$$

The required wire area is given:

$$A_{w\_aux} = \frac{I_{aux\_rms}}{6} \approx 0.0082mm^2$$

Wire diameter:

$$D_{w\_aux} \approx \sqrt{\frac{0.0082mm^2}{0.7854}} \approx 0.102mm$$

Convert using **Table 1: Wire Gauge Table** to SWG 42.

**Table 1: Wire Gauge Table**

Standard Wire Gauge (SWG)	Equivalent Wire Diameter (mm)	Equivalent Wire Area (mm <sup>2</sup> )
15	1.829	2.6268
16	1.626	2.0755
17	1.422	1.5890
18	1.219	1.1675
19	1.016	0.8107
20	0.914	0.6567
21	0.813	0.5189
22	0.711	0.3973
23	0.610	0.2919
24	0.559	0.2452
25	0.5080	0.2027
26	0.4572	0.1642
27	0.4166	0.1363
28	0.3759	0.1110
29	0.3454	0.0937
30	0.3150	0.0779
31	0.2946	0.0682
32	0.2743	0.0591
33	0.2540	0.0507
34	0.2337	0.0429
35	0.2134	0.0358
36	0.1930	0.0293
37	0.1727	0.0234
38	0.1524	0.0182
39	0.1321	0.0137
40	0.1219	0.0117
41	0.1118	0.0098
42	0.1016	0.0081
43	0.0914	0.0066
44	0.0813	0.0052
45	0.0711	0.0040
46	0.0610	0.0029
47	0.0508	0.0020
48	0.0406	0.0013
49	0.0305	0.0007
50	0.0254	0.0005



### 3.6 Select Inductor Core & Calculate Turns

The Ferroxcube catalog lists the following specifications for the E20/10/5 core set.

- $\Sigma(l_e/A_e)$  core factor =  $1.37 \text{ mm}^{-1}$
- $V_e$  effective volume =  $1340 \text{ mm}^3$
- $l_e$  effective length =  $42.8 \text{ mm}$
- $A_e$  effective area =  $31.2 \text{ mm}^2$

The air gap,  $G$ , of  $0.3\text{mm}$  may be used for initial calculation. The effective permeability of the core can be calculated:

$$\mu_e = \frac{\mu_i}{1 + \frac{G \cdot \mu_i}{l_e}}$$

Where  $\mu_i = 2000$  (for N27 material or 1P2400) and  $G = 0.3\text{mm}$ .

$$\mu_e = \frac{2000}{1 + \frac{0.3\text{mm} \cdot 2000}{42.8\text{mm}}} \approx 133$$

Calculate Inductance Factor  $A_L$  for this core:

$$A_L = \frac{\mu_0 \cdot \mu_e}{\sum \frac{l_e}{A_e}}$$

$$A_L \approx \frac{4\pi \cdot 10^{-7} \text{H} \cdot 133}{\text{m} \cdot \text{turn}^2} \cdot \frac{10^{-3}}{1.37} \approx \frac{121.99\text{nH}}{\text{turn}^2}$$

Where  $\mu_0 =$  vacuum permeability =  $4 \pi \cdot 10^{-7} \text{H/m}$ .

Calculate number of turns for the primary winding:

$$N_{\text{pri}} = \sqrt{\frac{L_{\text{pri}}}{A_L}} \approx \sqrt{\frac{4.535\text{mH}}{121.99\text{nH}} \cdot \text{turn}^2} \approx 193 \text{ turns}$$

Calculate the maximum flux density:

$$B_{\text{max}} = N_{\text{pri}} \cdot I_{\text{pri\_peak}} \cdot \frac{A_L}{A_e}$$

$$B_{\text{max}} \approx \frac{193\text{turn} \cdot 0.297\text{A}_{\text{peak}} \cdot \frac{121.99\text{nH}}{\text{turn}^2}}{31.2\text{mm}^2} \approx 0.224\text{T}$$

Note that  $B_{\text{max}}$  for 1P2400, MnZn ferrite, is  $0.36\text{T}$  at  $100^\circ\text{C}$ .

Calculate number of turns for secondary and auxiliary windings:

$$N_{\text{sec}} = N_{\text{pri}} \cdot \frac{N_S}{N_P} \approx 193\text{turns} \cdot 0.1515 \approx 29 \text{ turns}$$

$$N_{\text{aux}} = N_{\text{pri}} \cdot \frac{N_A}{N_P} \approx 193\text{turns} \cdot 0.0696 \approx 13 \text{ turns}$$

Calculate to make sure windings will fit the winding area of coil former. The Ferroxcube data sheet provides information for 8-pin coil former and specifies winding area of  $27\text{mm}^2$ .

The fill factor has to be taken into consideration as this will affect winding area for this coil former. In general we can use fill factor  $K_u$  of  $0.3$  to  $0.7$  as a starting point. In this case  $0.3$  will be selected.

$$\text{Total Winding Area} = \frac{1}{K_u} \cdot [(N_{\text{pri}} \cdot A_{w\_pri}) + (N_{\text{sec}} \cdot A_{w\_sec}) + (N_{\text{aux}} \cdot A_{w\_aux})] \leq 27\text{mm}^2$$

$$\text{Total Winding Area} \approx 3.33 \cdot [(193 \cdot 0.0234\text{mm}^2) + (29 \cdot 0.0937\text{mm}^2) + (13 \cdot 0.0081\text{mm}^2)] \leq 27\text{mm}^2$$

$$\text{Total Winding Area} \approx 24.44\text{mm}^2 \leq 27\text{mm}^2$$

**Note:** The total winding area should not be exceeded due to the selection of approximate standard wire gauges from **Table 1: Wire Gauge Table**.

### 3.7 Flyback Transformer Construction

The transformer block diagram shows the primary split into two sections, the first with 96 turns, the second with 97 turns. The secondary and auxiliary are wound between the two primary windings. The transformer stack-up has three layers of insulation tape between the primary and the secondary side. This method enables the transformer to pass the safety standard for

electrical strength requirement. In the previous step, we selected an air gap of 0.3mm as our starting point. The air gap is critical because it allows the transformer to extend its maximum saturation; however, if the gap is larger, then it could contribute to higher leakage inductance. In this example, it is possible to achieve a leakage inductance less than 2% of primary.

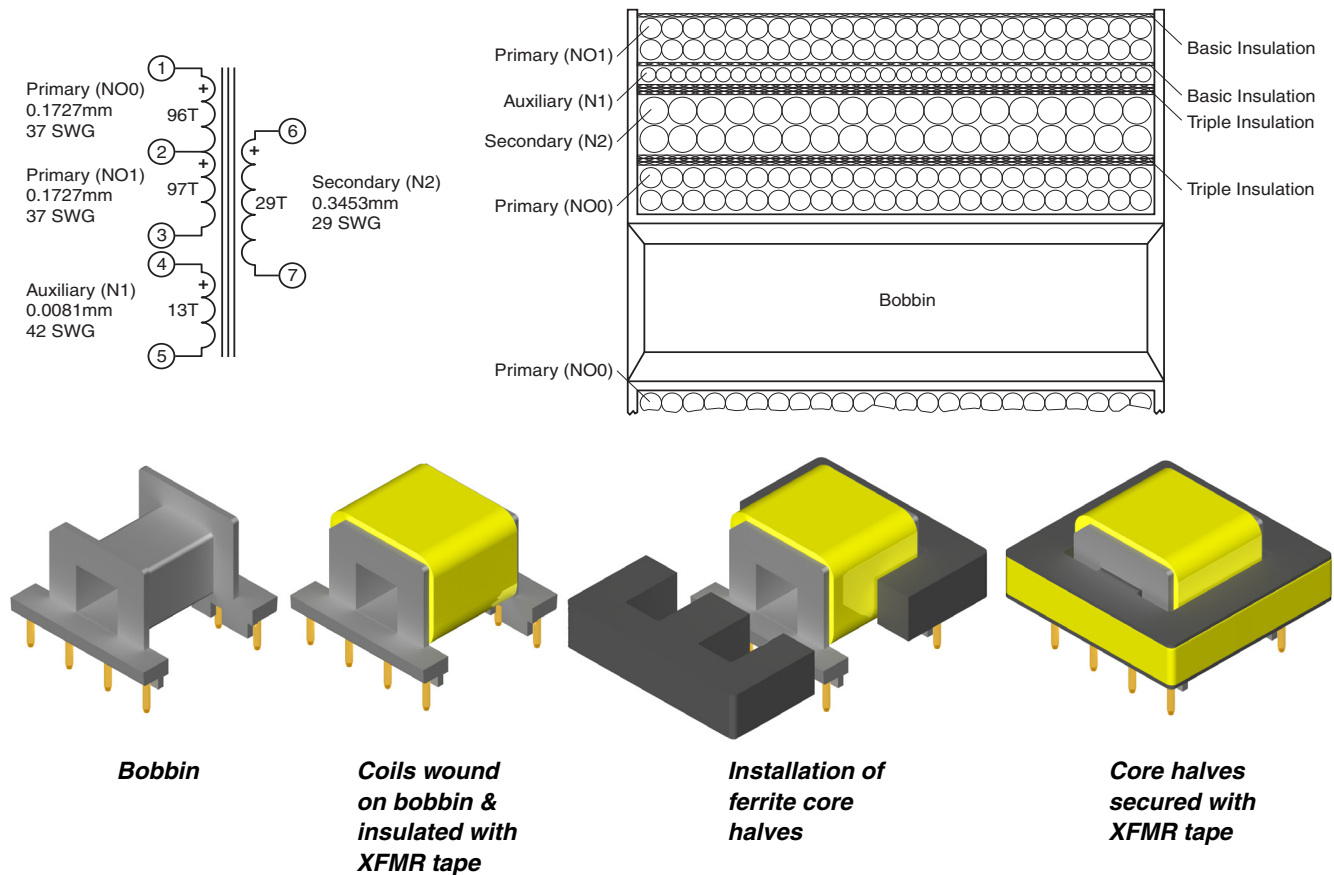

For additional information please visit our website at: [www.ixysic.com](http://www.ixysic.com)

IXYS Integrated Circuits Division makes no representations or warranties with respect to the accuracy or completeness of the contents of this publication and reserves the right to make changes to specifications and product descriptions at any time without notice. Neither circuit patent licenses nor indemnity are expressed or implied. Except as set forth in IXYS Integrated Circuits Division's Standard Terms and Conditions of Sale, IXYS Integrated Circuits Division assumes no liability whatsoever, and disclaims any express or implied warranty, relating to its products including, but not limited to, the implied warranty of merchantability, fitness for a particular purpose, or infringement of any intellectual property right.

The products described in this document are not designed, intended, authorized or warranted for use as components in systems intended for surgical implant into the body, or in other applications intended to support or sustain life, or where malfunction of IXYS Integrated Circuits Division's product may result in direct physical harm, injury, or death to a person or severe property or environmental damage. IXYS Integrated Circuits Division reserves the right to discontinue or make changes to its products at any time without notice.

Specification: AN-303-R02  
 ©Copyright 2016, IXYS Integrated Circuits Division  
 All rights reserved. Printed in USA.  
 7/14/2016