

95612

MM	IN
11.17	0.440
18.79	0.740
20.57	0.810
36.57	1.440
48.00	1.890

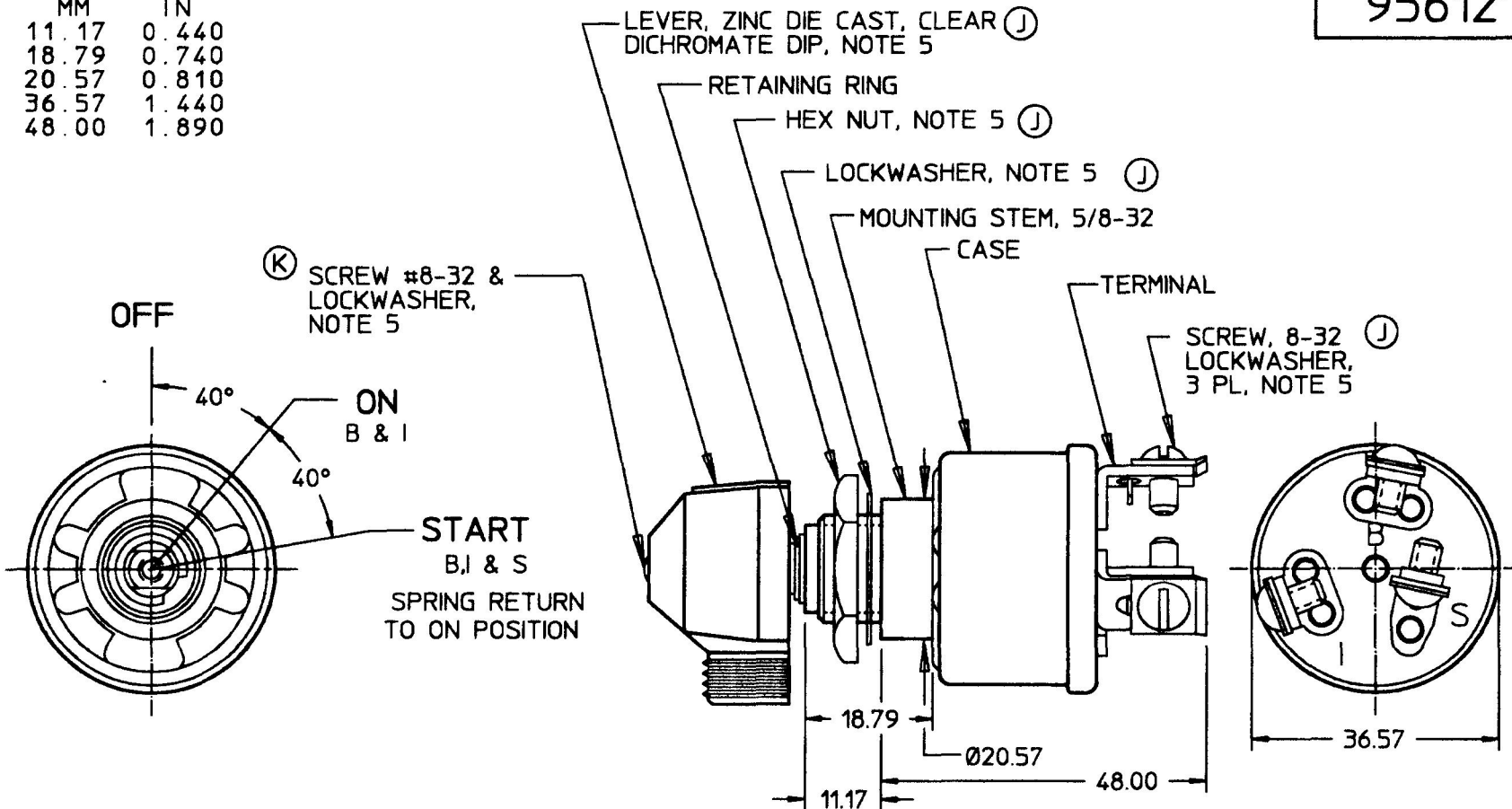

METRIC

I	IGNITION
S	START
B	BATTERY
LEGEND	

- NOTES:
1. SILVER LAMINATED CONTACT SURFACES
 2. MELAMINE LINER
 3. ALL STEEL PARTS PLATED
 4. O-RING SEAL AT MOUNTING STEM
 5. PARTS MAY BE ASSEMBLED OR SUPPLIED IN A BAG
 6. RATING: START 20 AMPS @ 12V DC
IGN 25 AMPS @ 12V DC
 7. APPLICABLE SAE STANDARD OR RECOMMENDED PRACTICE SAE J259
 8. ALL DIMENSIONS REFERENCE ONLY

DO NOT SCALE

LET.	WAS	DATE	BY	LET.	WAS	DATE	BY	MATERIAL	DRAWN	CHK	APVD	SCALE	DATE DRAWN
									MF	<i>ML</i>		1:1	2/25/64
								FINISH	Cole Hersee Co. 20 OLD COLONY AVENUE, BOSTON, MA., U.S.A. 02127				DATE BLUEPRINTED
				K	ECN #98160	02/28/98	ML	TOLERANCES	SWITCH, IGNITION & START HEAVY DUTY, 3 POSITION				95612
				J	ECN #26813 PUT ON CAD	7/16/97	AJS	DECIMAL ± ANGLE ±					