

MM	IN
0.76	0.030
1.01	0.040
1.52	0.059
1.57	0.061
2.03	0.080
2.28	0.090
3.04	0.120
3.55	0.140
4.82	0.190
9.14	0.360
9.39	0.370
13.66	0.538
19.81	0.780
20.06	0.790
46.48	1.830
46.99	1.850

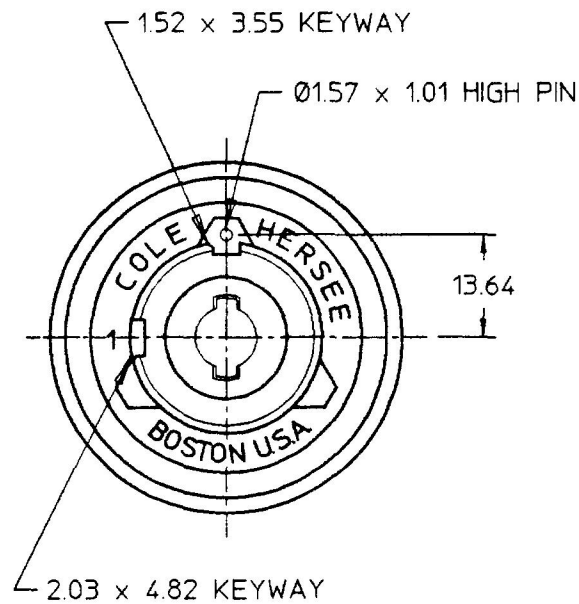

FRONT VIEW SHOWN W/O KEY AND FACE NUT

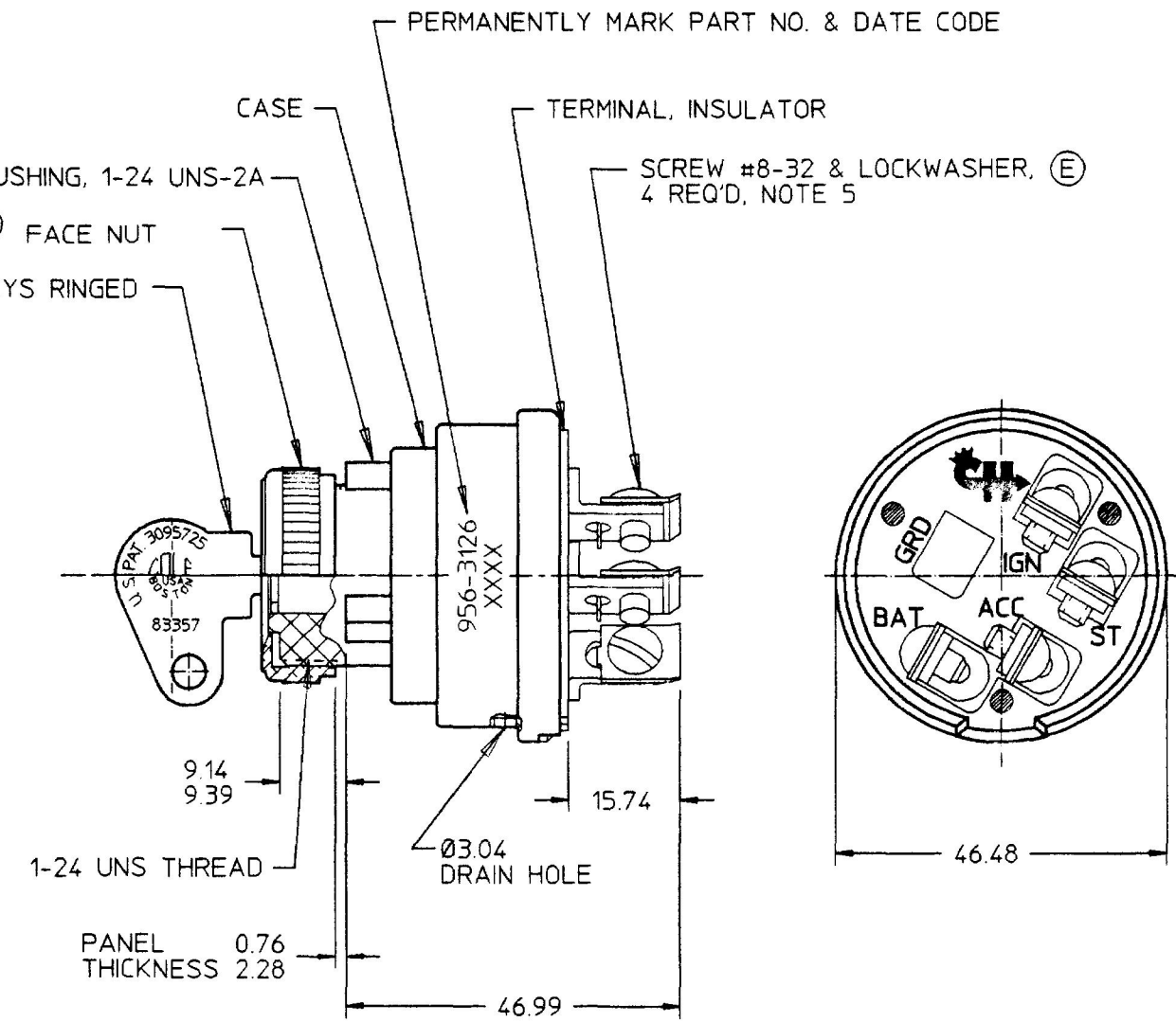
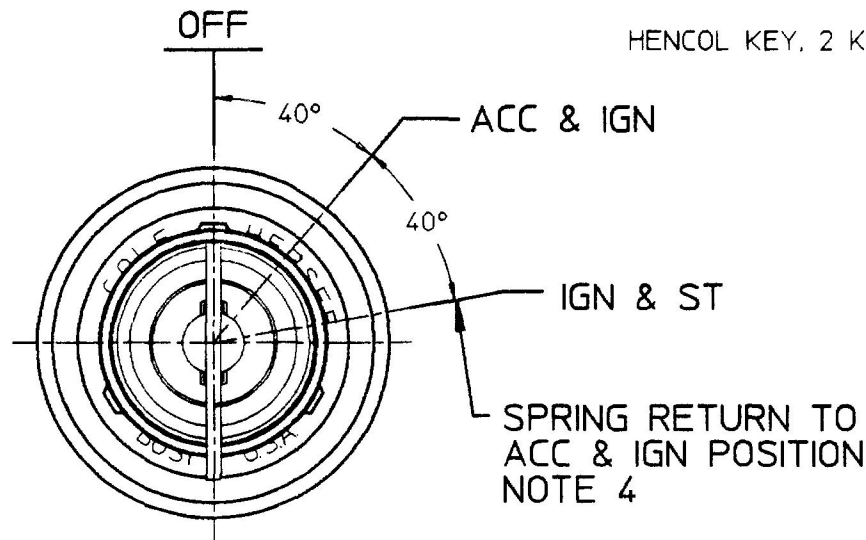

- NOTES:
1. ALL DIMENSIONS ARE REFERENCE ONLY
  2. ALL STEEL PARTS PLATED
  3. TERMINAL INSULATOR GASKET SEALED
  4. START LOCK-OUT FEATURE, SWITCH MUST GO TO "OFF" POSITION BEFORE START CIRCUIT CAN BE RE-ENERGIZED
  5. PARTS MAY BE ASSEMBLED OR SUPPLIED IN A PLASTIC BAG
  6. APPLICABLE SAE STANDARD OR RECOMMENDED PRACTICE SAE J259

DO NOT SCALE

LET.	WAS	DATE	BY	LET.	WAS	DATE	BY	MATERIAL	DRAWN	CHK	APVD	SCALE	DATE DRAWN
									KG	Jmp		1:1	10/27/97
								FINISH	<b>Cole Hersee Co.</b> 20 OLD COLONY AVENUE, BOSTON, MA., U.S.A., 02127				DATE BLUEPRINTED
				F	ECN #98258	04/29/98	COL	TOLERANCES	SW, IGN & START, 3 POS				956-3126
				E	PUT ON CAD ECN #26936	9/12/97	AJS	DECIMAL ± ANGLE ±					

METRIC